



karmetal
*SAW*lutions





KDG 300x500
HORIZONTAL SEMI AUTO MITER
BAND SAW MACHINE

*Photo may feature machine with optional accessories

KDG 300x500 Semi Auto Miter Band Saw Machine

CUTTING CAPACITY

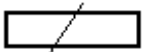
	0°	45°	60°
	300 mm	290 mm	180 mm
	280 mm	250 mm	160 mm
	280 x 420 mm	250 x 260 mm	80 x 280 mm

TECHNICAL SPECIFICATIONS

<i>Main Motor</i>	: 2, 2 kW
<i>Gearbox</i>	: Bevel Helical PKD 1390 High Efficiency
<i>Hydraulic Motor</i>	: 0, 37 kW
<i>Coolant Motor</i>	: 0, 12 kW
<i>Blade Speed</i>	: 25-90 m/min
<i>Blade Dimensions</i>	: 3.850 x 27 x 0, 9 mm
<i>Machine Weight</i>	: 840 kg
<i>Machine Dimensions</i>	: 1.300 x 1.950 x 1.300 mm
<i>Table Height</i>	: 740 mm

STANDARD ACCESSORIES

Manual Control Panel

Only control panel with buttons.



Inverter

Provides to adjust blade speed up to workpiece diameter, thickness and hardness.



Hydraulic Vise

Pressure, clamping period and clamping time can be adjusted.



Hydramechanical Blade Tensioning

Tensioning period and tensioning time can be adjusted. So blade does not relax and curve cutting gets prevented.



Swarf Brush

Removes swarfs to keep clean the wheels and blade.

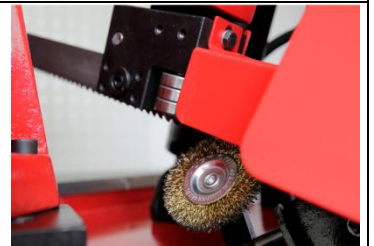

Blade Bedding with Carbide and Bearing



Manometer



Rotating Table

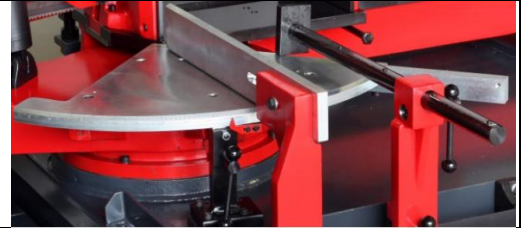

Rotating Vise Flange



Bevel Helical Gearbox



Moveable Guide Arms



Single Roller Table



60 cm Long Material Stopper System



S.A.P (Italy) Brand Coolant Pump



Easy Readable Angle Ruler



Adjustable Bow Down Speed



Adjustable Vise Pressure



Transport Hooks



Levelling Foot Leg



Cover Switch



Tension Switch



Electric Cabinet Switch



Wheel Bedding with Bearing



Rollers to Support Feeding Material



1,4m Roller Table



Automatic Stop When;

- The covers are open
- Blade is broken
- Blade tension is low

OPTIONAL ACCESSORIES

Laser Line Indicator



Micro Molecular Coolant System



SAFETY EQUIPMENTS

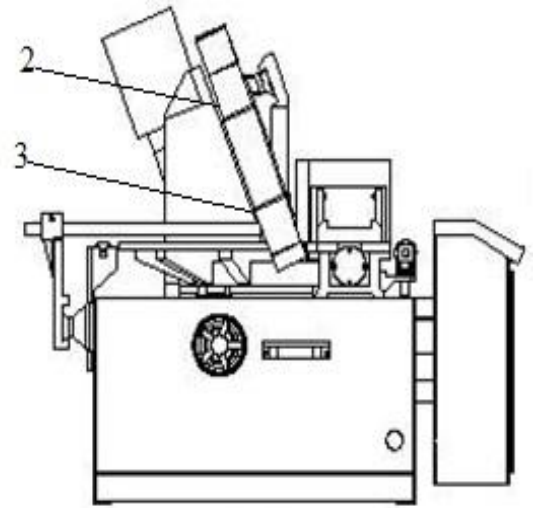
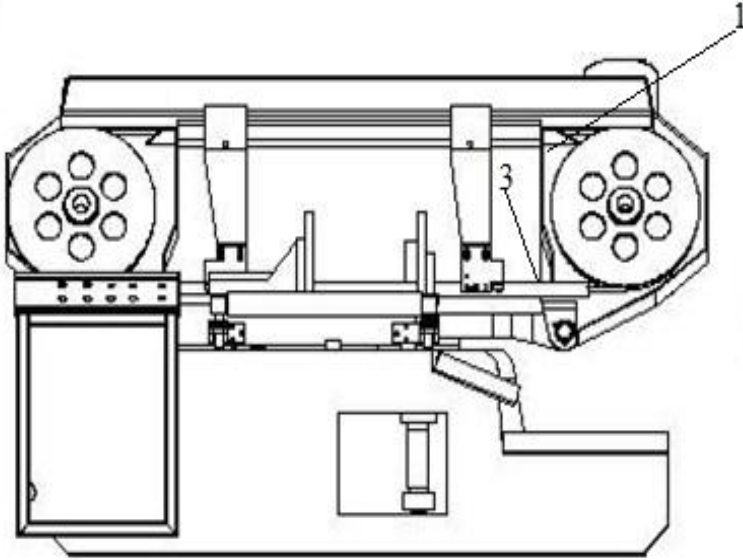

<u>NO</u>	
1	Right Cover Switch
2	Hydraulic Band Tension Switch
3	Upper Limit Switch
	Lower Limit Switch

TERMS

Delivery (After Receipt of written PO) :

Type of Delivery : **Exwork**

WARRANTY CONDITIONS

The machine is under the warranty of KARMETAL LTD. ŞTİ. For a period of 2 years for mechanical parts, 1 year for electric and electronic parts from the date of purchase. This warranty is subject to all of the terms and conditions listed below:

1. This warranty is valid only if the **Warranty Registration Form** is filled in and returned to the manufacturer or its authorized dealer within **two months after the** date of purchase.
2. The obligation of the manufacturer under this warranty shall be limited to repairing or replacing components which proves defective and which our examination shall disclose to our satisfaction to be defective.
3. Defects due to improper operation, misuse, neglect, alteration, irregular voltage conditions, inadequate wiring, improper installation (**all electrical and electronic components, all electrical motors etc.**) and due to accidents or any damage caused by transportation, flood, fire, natural disasters, theft are not included in this warranty and are strictly the responsibility of the purchaser.
4. Any part returned to KARMETAL or its authorized dealer under the terms of this warranty shall be on the basis of transportation charges prepaid by the customer and must be accompanied by a record of the machine model code and serial number.
5. This warranty does not apply to the following components; band saw blade, blade pressure pads or brackets and blade guide bearings **because of being consumables.**
6. Manufacturer and authorized dealer cannot be blamed within maximum repair period for the material or moral damage. Apart from that act the period as Warranty Conditions and there will not be done any retroactive requirement.



KARMETAL SANAYI ve TICARET LIMITED SİRKETİ

Hanlı Merkez Mah. Hatip Sok. No:32

Arifiye/Sakarya/TURKEY

Phone: +90 264 276 59 16

Fax: +90 264 276 59 19

www.karmetal.com.trsales@karmetal.com.tr



Machine videos are available on:

