

Retractable Assembly *CleanFit COA 451*

**Manually operated stainless steel assembly
with ball valve for the oxygen sensors COS 3, COS 31
and COS 41**



Application

- Process measurement
- Water and wastewater treatment
- Drinking water
- Monitoring of surface water
- Fish farming

Your benefits

- Safety:
 - Safe and reliable process termination possible under nearly all conditions
 - Process pressure up to 10 bar (145 psi), manually operated up to 2 bar (29 psi)
- Comfortable operation:
 - Cleaning possible due to rinse water connection
 - Rinse water connection can be used as sealing water inlet
 - Sensor monitoring and cleaning without process interrupt



Function and system design

Function

The assembly is manually operated.



Caution!

The air relief valve and the rinse connections (if used) are in open contact with the medium in the measuring position, or at least when moving, and are thus exposed to the process pressure. Make sure that, the air relief valve and the rinse connections (if used) are closed when moving the assembly .

General sequence when moving the retractable assembly

- from position "Service" to position "Measure"
 - Open the ball valve (see fig. below, pos. 1)
 - Move the sensor into the process: press down the handle (pos. 6) of the sensor holder (pos.3)
 - Close the bayonet joint (pos. 5)
 - Fasten the fastening screws (pos. 4)
- from position "Measure" to position "Service"
 - Loosen the fastening screws
 - Open the bayonet joint
 - Move the sensor off the process: pull up the sensor holder by means of the handle
 - Close the ball valve

In the "Service" status (sensor moved back into the assembly and **ball valve closed**), the ball valve seals the assembly off from the process. This means that cleaning and calibration can take place and electrodes can be changed without interrupting the process.



Caution!

Manually moving the assembly under process conditions is only possible at a process pressure up to 2 bar (29 psi).

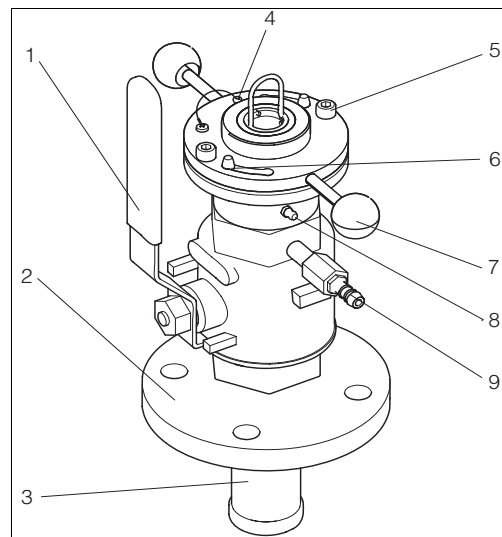

Assembly in measuring mode (ball valve open)

- 1 Hand lever for ball valve open/close
- 2 Process connection (Flange DN 50 / PN 16)
- 3 Outer sleeve
- 4 Locking pin
- 5 Fastening screws
- 6 Bayonet joint
- 7 Handle
- 8 Lubricator nipple
- 9 Air relief valve resp. rinse water connection

Measuring system

A complete measuring system comprises:

- CleanFit COA 451 assembly
- OxiMax W COS 31, OxiMax W COS 41 or OxiMax W COS 3 oxygen sensor
- Liquisys M COM 223/253 transmitter

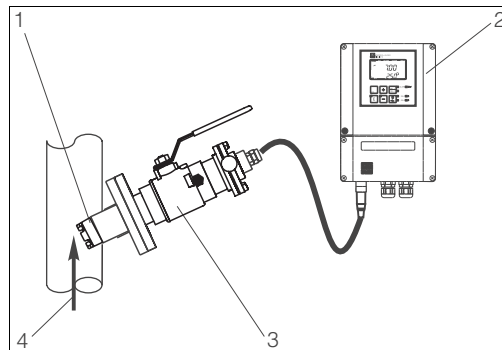

C07-COA451xx-14-05-00-xx-001.eps

Measuring system

- 1 COS 31, COS 41 or COS 3
- 2 Liquisys M COM 253
- 3 COA 451
- 4 Medium flow direction

Installation

Installation conditions

Install the assembly at places with constant flow. The minimum pipe diameter is DN 80.

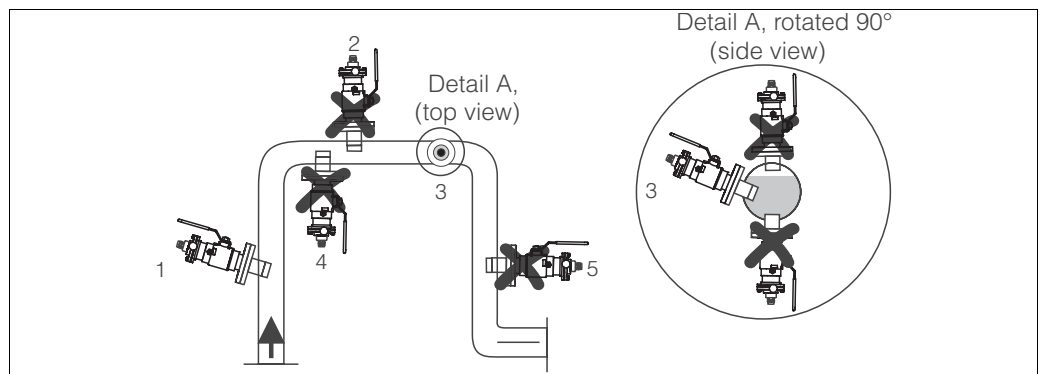

C07-COA451xx-11-07-00-en-001.eps

Permissible and impermissible sensor installation positions

- 1 Ascending pipe, best position
- 2 Horizontal pipe, sensor top down, impermissible due to air cushion or foam bubble forming
- 3 Horizontal pipe, installation with permissible emitting angles (acc. to sensor version)
- 4 Overhead installation, impermissible due to missing electrolyte contact of the sensor electrodes
- 5 Down pipe, impermissible



Note!

- Do not install the assembly at places, where air cushions or foam bubbles can be formed or where suspended particles can settle on the sensor optics (→ Fig.).
- Measuring errors can occur, if:
 - the sensor is not immersed into the medium
 - suspended particles are settled on the sensor membrane
 - the sensor is installed overhead.

Orientation

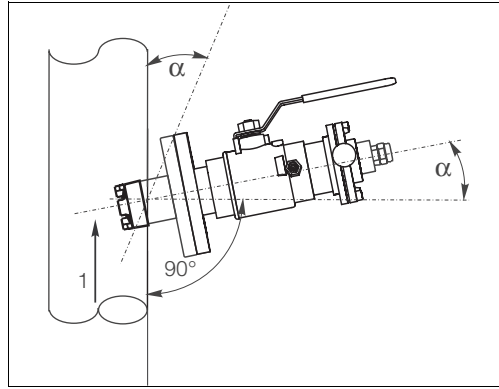

C07-COA451xx-11-07-00-xx-003.eps

Ascending pipe and tank side installation

α min 15°
1 Medium flow direction

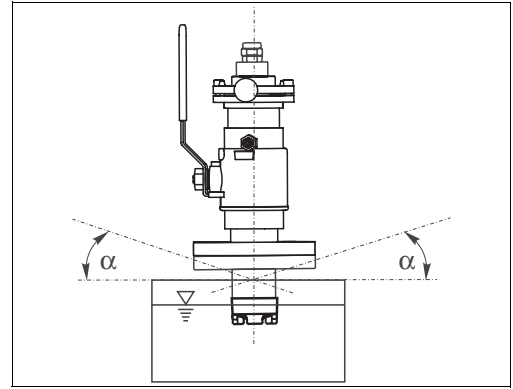

C07-COA451xx-11-07-00-xx-002.eps

Tank top installation

α min. 15°
1 Medium flow direction

Environment

Ambient temperature range 0 ... 50 °C (32 ... 122 °F)

Process

Medium pressure max. 10 bar (145 psi)



Caution!
 • The maximum process pressure is 2 bar (29 psi) for manual assembly operation!
 • Please consider the sensor process conditions!

Medium temperature 0 to 80 °C (32 to 176 °F)



Caution!
 Please consider the maximum sensor process temperature!

Pressure-temperature diagram

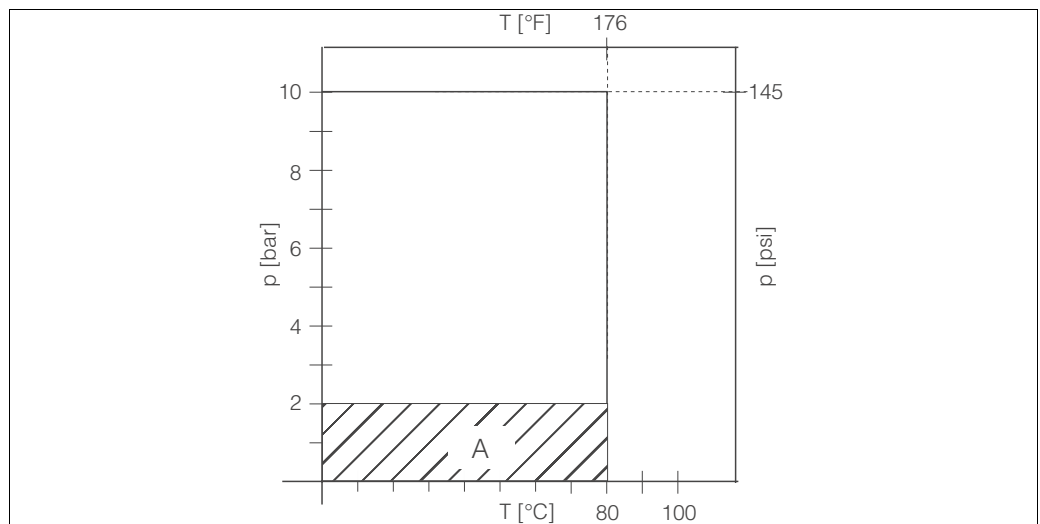

C07-CYA451x-05-07-00-en-001.EPS

Pressure-temperature diagram

A Manual operation range

Mechanical construction

Design, dimensions

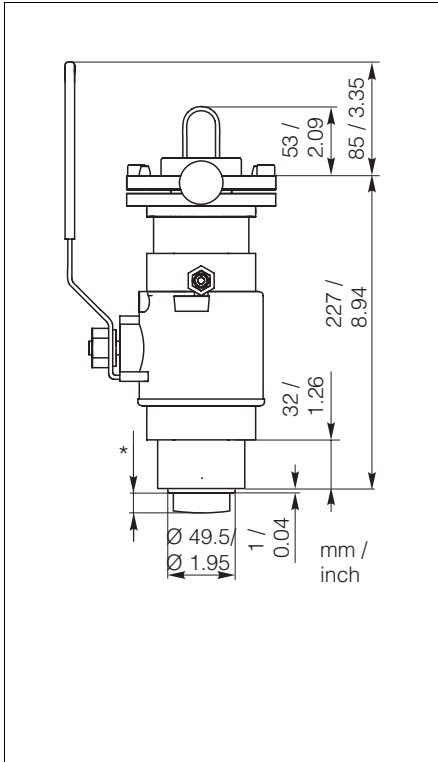

C07-CUA451xx-06-07-en-003.eps

Assembly with welding neck (short lift)

* Dimensions depend on sensor, see below

*** There must be additional space of 350 mm (13.78") for sensor installation!

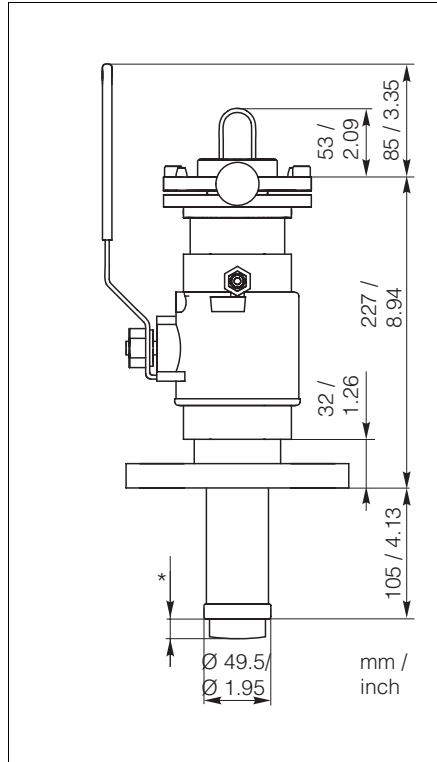

C07-CUA451xx-06-07-00-en-002.eps

Assembly with flange connection (long lift)

* Dimensions depend on sensor, see below

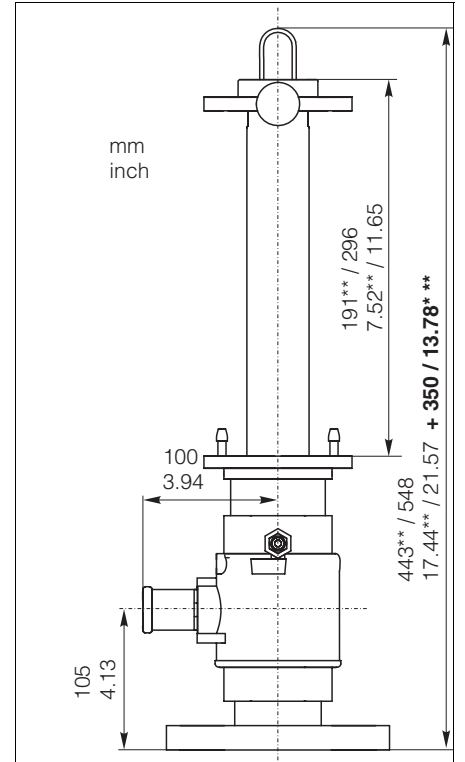

C07-CUA451xx-06-07-00-en-001.eps

Assembly in service position

** Assembly version with short lift (see product structure)

* Dimension acc. to sensor type:

COS 31: 8 mm (0.31")

COS 41: 11 mm (0.43")

COS 3: 16 mm (0.63")

Fitted sensors

COS 31, COS 41 or COS 3

Weight

8 - 11 kg (17.6 ... 24.3 lb) depending on the assembly version

Materials

In contact with medium:

Viton (seals)

stainless steel 1.4404 (AISI 316L)

nickel brass (air relief valve resp. rinse connection)

Not in contact with medium:

stainless steel 1.4404 (AISI 316L)

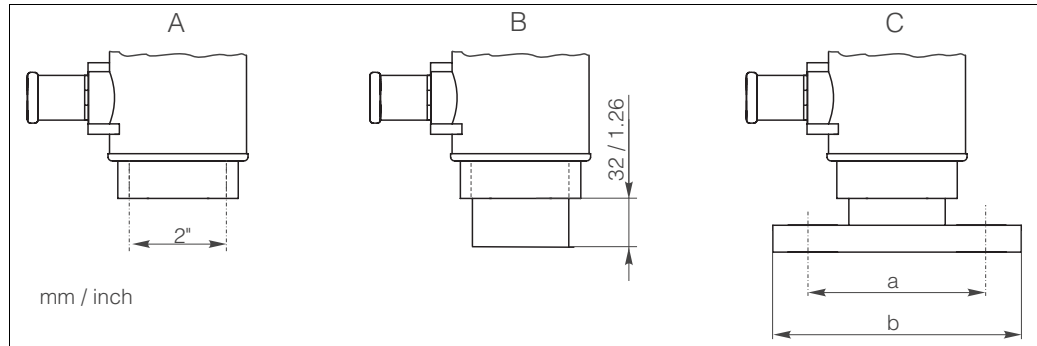
Process connections

C07-CUA451xx-04-07-00-en-001.eps

Process connections

- A Internal thread G2
 B Internal thread G2 with welded fitting
 C Flange DN 50 / PN 16 and Flange ANSI 2" / 150 lbs
 a: DN 50: Ø 125 (4.92"), ANSI 2": Ø 120.7 (4.75")
 b: DN 50: Ø 165 (6.50"), ANSI 2": Ø 152.4 (6.00")

Rinse connection fitting

2 x G1/8 (internal)

Connection options:

- 2 x ball valve with hose connection OD 9 mm (0.35"), see accessories
 (One ball valve is in the scope of delivery. When used alone, it is an air relief valve.)
- customer specific solution, rinse connections with G1/8 external thread

Air relief valve

Hose connection OD 9 mm (0.35")

Ordering information**Product structure**

Sensor lift / Immersion depth	
A	Short lift, Immersion depth approx. 170 mm / 6.69" (process connections A and B only)
B	Long lift, Immersion depth approx. 270 mm / 10.63"
Sensor type / Connection	
1	For COS 31 with G1, Sensor length approx. 200 - 220 mm / 7.87 - 8.66"
2	For COS 41 / COS 3 with G1, Sensor length approx. 140 - 160 mm / 5.51 - 6.30"
Process connection	
A	G2 internal thread
B	G2 internal thread with welded fitting h = 50 mm / 1.97"
C	Flange DN 50 / PN 16 acc. to EN 1092/1
D	Flange ANSI 2" / 150 lbs
COA 451-	complete order code

Accessories**Assembly**

- Ball valve for rinse connection; order no. 51512982
- O-ring set, Viton; order no. 51512981

Process connection adapter

- Welded fitting for pipe diameters of more than 80 mm (3.15"), with combination flange DN 50 / ANSI 2":
 - Bore holes for DN 50 flange: 4 x 90° Ø18 (0.71") on hole circle Ø125 (4.92")
 - Bore holes for ANSI 2" flange: 4 x 90° Ø19 (0.75") on hole circle Ø121 (4.76")
- Flange seal, 4 screws M16x60, 4 nuts M16 incl. washers, stainless steel 1.4571 (AISI 316Ti); order no. 50080249

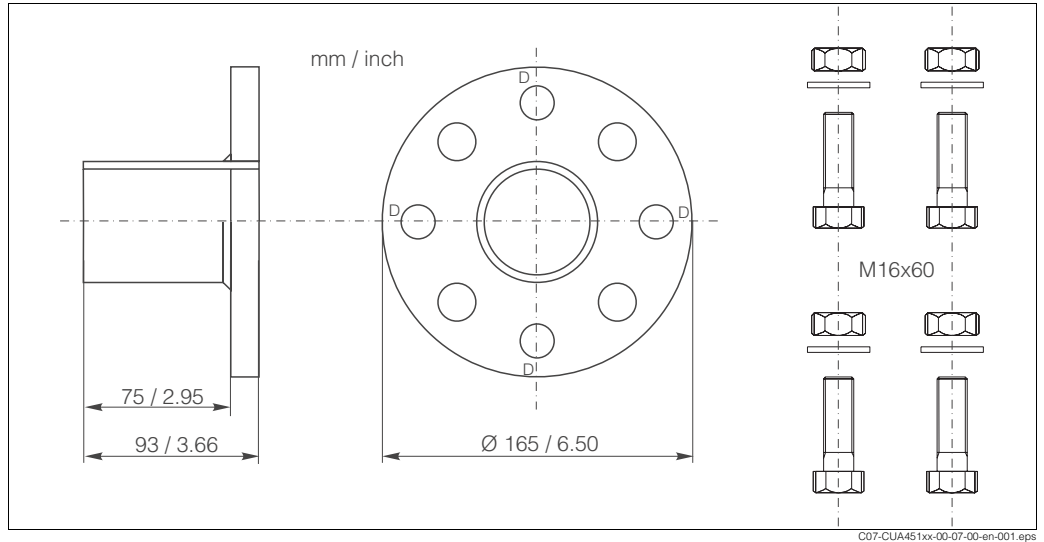

C07-CUA451xx-00-07-00-en-001.eps

Welded fitting

D: Marks for the bore holes of the DN 50 flange

Sensors

- OxiMax W COS 31
 - oxygen sensor for drinking water and wastewater measurements, SS 1.4571 (AISI 316Ti), potentiostatic amperometric principle
 - ordering acc. to product structure, see Technical Information
- OxiMax W COS 41
 - oxygen sensor for drinking water and wastewater measurements, POM, potentiostatic amperometric principle
 - ordering acc. to product structure, see Technical Information

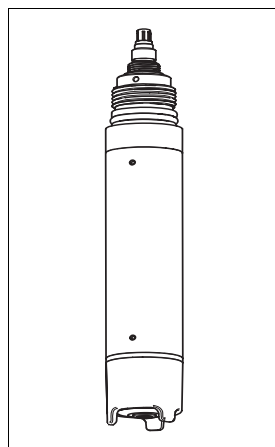

C07-COS31xxx-00-05-06-xx-001.eps

OxiMax W COS 31

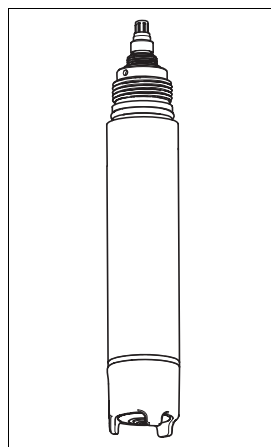

C07-COS41xxx-00-05-06-xx-001.eps

OxiMax W COS 41

Profiling plates

- Profiling plates for welded fittings; order no. 51513623

Documentation

- Operating Instructions CleanFit COA 451, BA 368C/07 (order no. 51512834)
- Technical Information OxiMax W COS 31, TI 285C/07 (order no. 51506693)
- Technical Information OxiMax W COS 41, TI 284C/07 (order no. 51506689)

Endress+Hauser GmbH+Co. KG

Instruments International
P.O. Box 2222
D-79574 Weil am Rhein
Germany

Tel. (07621) 975-02
Tx 773926
Fax (07621) 975 345
e-mail: info@ii.endress.com

Internet:

<http://www.endress.com>

Endress + Hauser
The Power of Know How

