



Level



Pressure



Flow



Temperature

Liquid
Analysis

Registration

Systems
Components

Services



Solutions

Technical Information

Cleanfit P CPA473

Retractable stainless steel process assembly with ball valve for pH and ORP electrodes



Application

- Chemical industry
- Paper industry
- Wastewater / industrial water
- Power plants
- Refuse incinerators
- Sugar industry

This assembly is very well suited to applications with fibrous contents or media which have a tendency to stick and could thereby interfere with the sealing system.

Your benefits

- Safety:
 - Safe and reliable process termination possible under nearly all conditions
- Comfortable operation:
 - Assembly service in ongoing process: total disassembly of assembly body possible with closed ball valve (e.g. for exchanging sealing rings, electrode holder etc.)
 - Various immersion depths (tank/pipe installation)
 - Sealing water to screen off rinse chamber
- Automation even for difficult processes:
 - Fully-automatic calibration and cleaning in conjunction with Topcal S CPC310
- Easy installation:
 - Version with pneumatic ball valve drive is supplied fully hosed-up
 - Replaceable packing sleeve for easy seal replacement

Function and system design

Principle

The "Measure" and "Service" operating statuses can be changed in the following ways:

- Manually
- Pneumatically
- Pneumatically via Topcal S CPC310 or Topclean S CPC30 with optional CPR40 rinsing block
- All versions possible with limit position switch.

Principle sequence when moving the retractable assembly

- from "Service" to "Measure"
 - Open ball valve
 - Move assembly
- from "Measure" to "Service"
 - Move assembly
 - Close ball valve

In the "Service" status (sensor moved back into the assembly), the ball valve seals the assembly off from the process. This means that cleaning and calibration can take place and electrodes can be changed without interrupting the process.

Warning!

The **rinse chamber** and the **rinse connections** of the assemblies are **in open contact with the medium in the measuring position**, or at least when moving, and are thus exposed to the **process pressure**.

For this reason, the inlet and outlet of the rinse chamber **must be protected by valves**. These valves are available from Endress+Hauser as accessories (see product structure, "Additional equipment"). These valves close automatically in the pneumatic version.

Sealing system

The patented packing sleeve (made of PEEK) seals between the pneumatic drive system and the rinse chamber. The packing sleeve contains three radial seals. Additionally the packing sleeve improves the guidance of the sensor.

For both sides of the ball valve are scrapers optionally available (pos. 3 + 4).

Caution!

When the assembly is in the service position and the ball valve is open, the process pressure acts on the rinse connections. Therefore the rinse connections must be equipped with inlet and outlet safety seal.

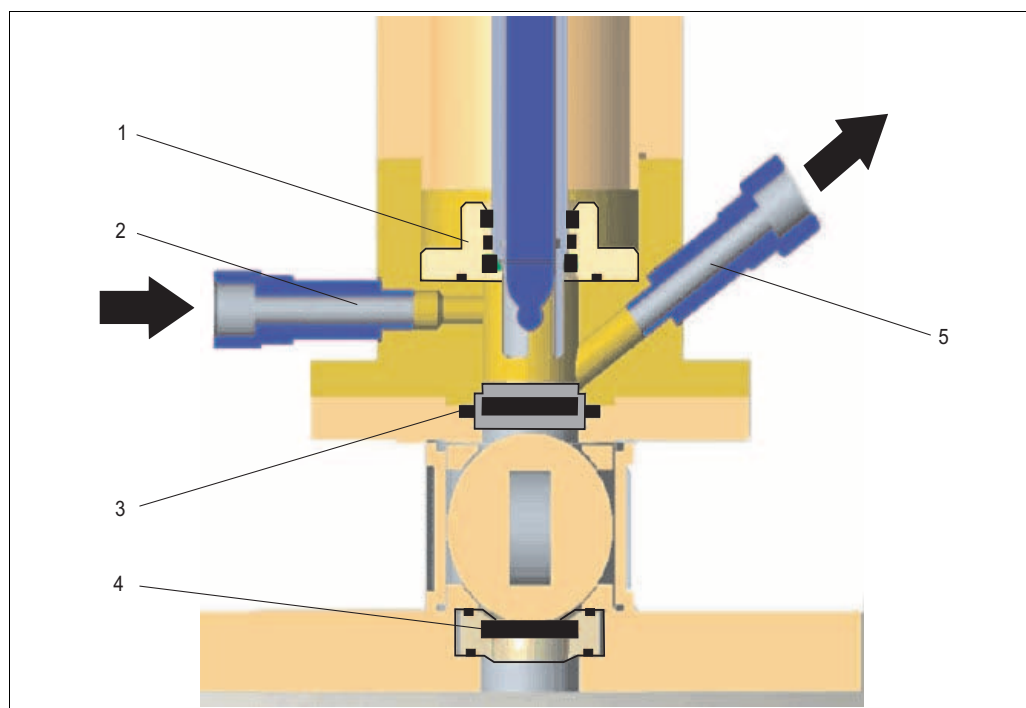

Sealing system

- 1 Packing sleeve (made of PEEK) with 3 seals
- 2 Rinse inlet
- 3 Scraper PVDF/PTFE
- 4 Scraper PEEK with O-rings
- 5 Rinse outlet with manual or pneumatic outlet safety seal

Sealing water function

For the sealing-water function the assembly must be equipped with a pneumatic outlet safety seal for rinse chamber outlet (see chapter "Accessories").
 For sealing water the scraper no. 3 (above the ball valve) can be removed if needed.

Limit position switches

The pneumatic limit position switches serve as control elements and determine the sequence of the individual steps.

The following types of limit position switches are available depending on the order version (product structure, "Assembly operation, ball valve"):

- "Pneumatic limit position switch" version: 4 pneumatic switches (type, see "Mechanical construction")
- "Electric limit position switch" version: 3 pneumatic and 2 inductive switches (types, see "Mechanical construction")

Function

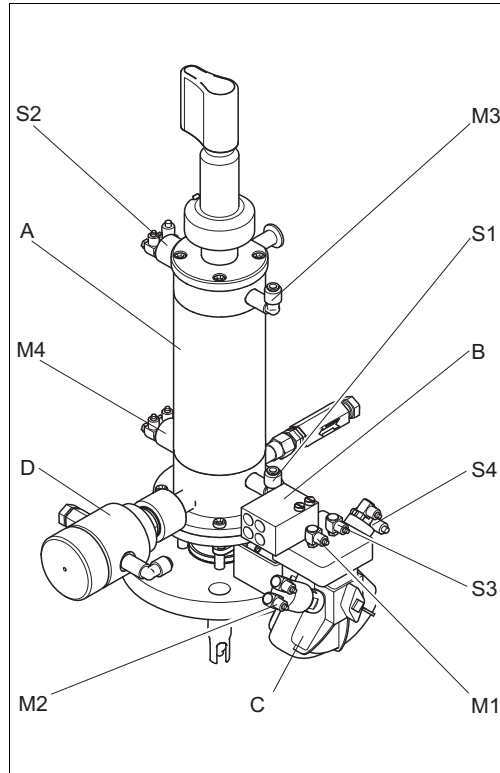

Pneumatic limit position switches

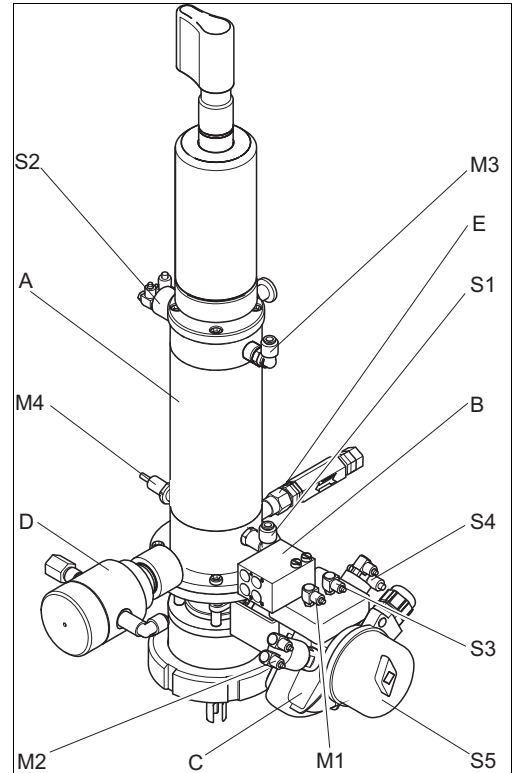

Electrical limit position switches

- A Assembly cylinder
- B Pneumatic connection block
- C Ball valve drive
- Measuring:**
- M1 Pneumatics "Open ball valve"
- M2 Limit position switch "Ball valve open"
- M3 Pneumatics "Assembly Measuring"
- M4 Limit position switch "Assembly Measuring"

- D Rinsing input / output
- E Rinse inlet with non-return valve
- Service:**
- S1 Pneumatics "Assembly Service"
- S2 Limit position switch "Assembly Service"
- S3 Pneumatics "Close ball valve"
- S4 Limit position switch (pneu.) "Ball valve closed"
- S5 Limit position switch (el.) "Ball valve closed"

Assembly moving principle

Moving from "Service" position into "Measure" position

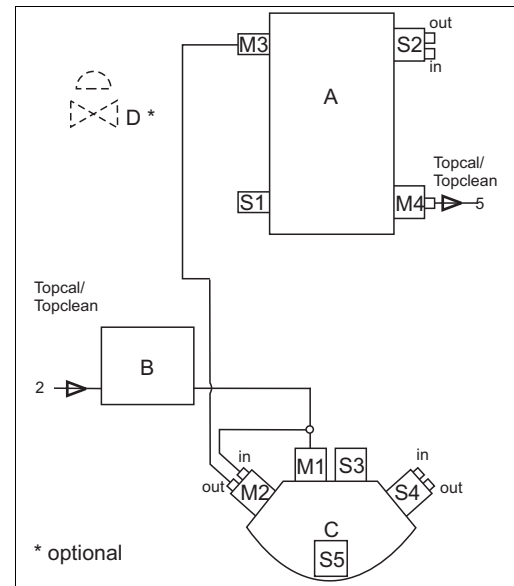
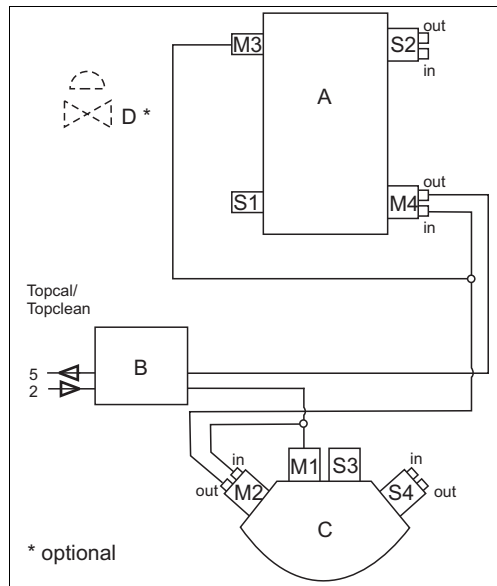

Move to "Measuring" position, version with pneumatic limit position switches

in Pneumatic input, limit position switch
 out Pneumatic output, limit position switch
 5 Feedback signal "Assembly measuring"
 2 Compressed air input "Start measuring"

Move to "Measuring" position, version with electric limit position switches

A Assembly cylinder
 B Pneumatics connection block
 C Ball valve drive
 D Outlet safety seal for rinse chamber

1. Compressed air is provided at position M1 (pneumatic "Open ball valve"). At the same time, compressed air is applied to M2 (limit position switch "Ball valve open"). The ball valve (C) opens. **The rinse chamber outlet valve (D) must be closed.**
2. When the ball valve is completely open, the limit position switch M2 forwards compressed air to the pneumatics of the pressure cylinder, input "Assembly measuring" (M3) and simultaneously to the limit position switch "Assembly measuring" (M4). The electrode holder moves out of the assembly into the medium.
3. Once the limit position is reached, the limit position switch M4 sends a signal (5, "Assembly measuring" feedback signal) to the transmitter / DCS or to Topcal S / Topclean S.

Moving from "Measure" position into "Service" position

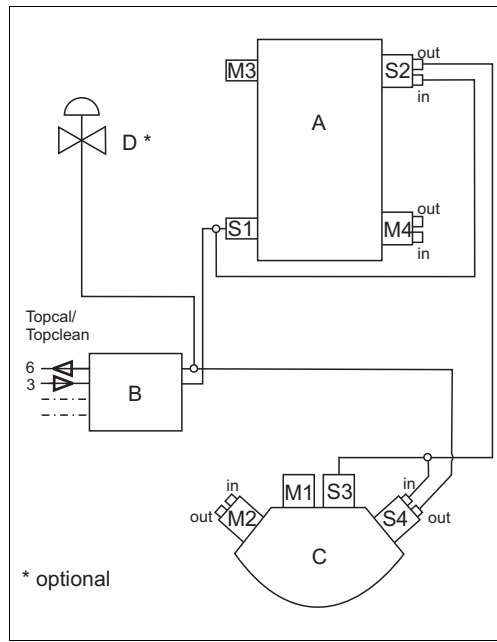

Move to "Service" position, version with pneumatic limit position switches

in Pneumatic input, limit position switch
 out Pneumatic output, limit position switch
 6 Feedback signal "Assembly service"
 3 Compressed air input "Start service"

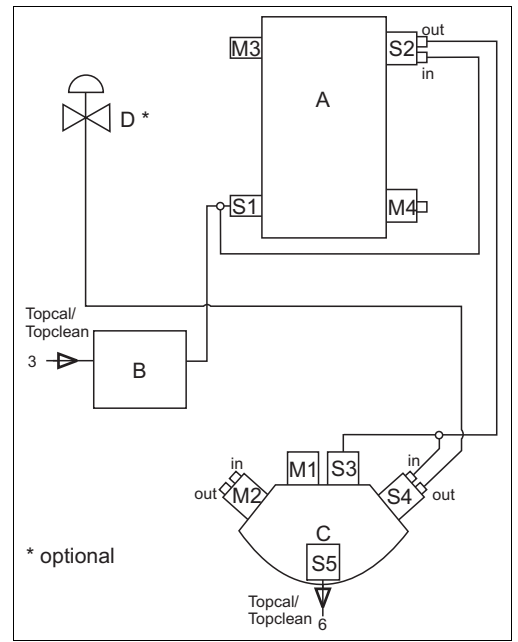

Move to "Service" position, version with electric limit position switches

A Assembly cylinder
 B Pneumatics connection block
 C Ball valve drive
 D Outlet safety seal for rinse chamber

1. Compressed air is simultaneously provided at the pneumatics of the pressure cylinder, input "Assembly service" (S1) and at the limit position switch "Assembly service" (S2). The electrode holder moves from the medium into the assembly.
2. When the limit position is reached, the limit position switch S2 forwards pressure to position S3 (close ball valve) and position S4 (limit position switch "Ball valve closed") simultaneously. The ball valve (C) closes.
3. Once the ball valve is completely closed, a signal (6, "Assembly service" feedback signal) is sent from the limit position switch S4 (or the limit position switch S5 in case of the version with electric limit position switches) to the transmitter / DCS or to Topcal S / Topclean S. At the same time, pressure is applied to the rinse chamber outlet valve (D). Valve D opens as long as the pressure is applied. Any drop in pressure causes this valve to close.

Measuring system without control

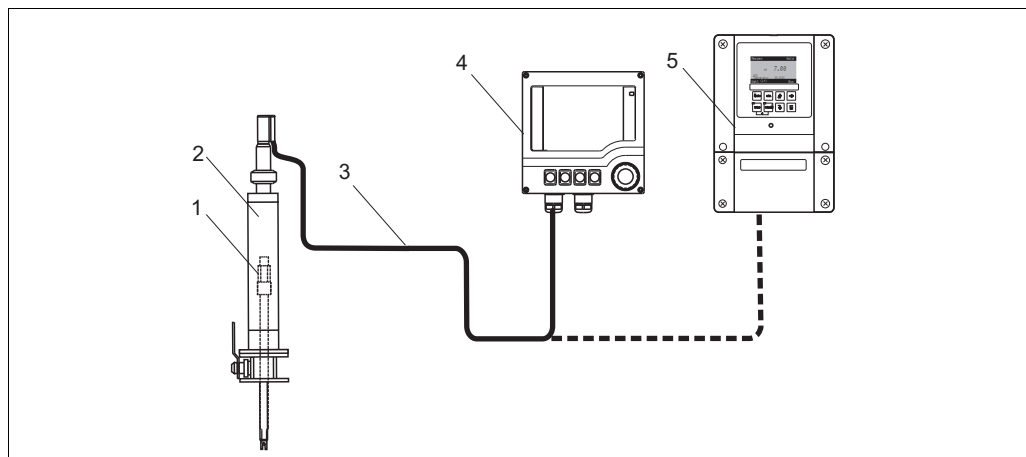

Measuring system without control (example)

a0011433

- | | | | |
|---|----------------------------|---|---------------------------------|
| 1 | pH/ORP sensor | 4 | Transmitter Liquiline M CM42 or |
| 2 | Assembly Cleanfit | 5 | Transmitter Mycom S CPM153 |
| 3 | Special pH measuring cable | | |

Measuring system with pneumatic control

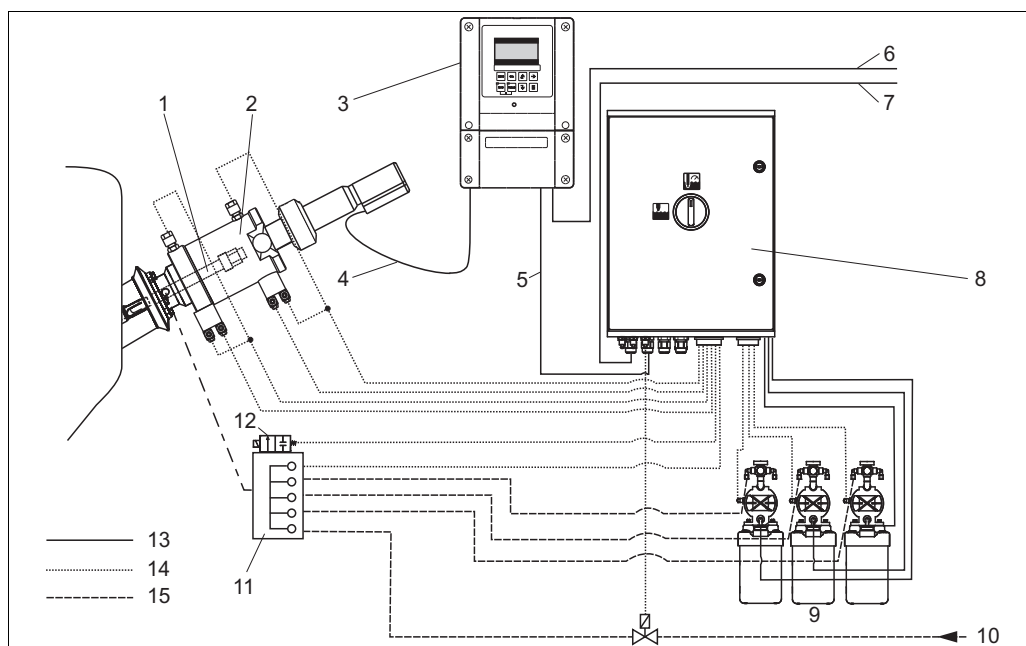

Measuring system with pneumatic control

a0006077

- | | | | |
|---|------------------------------------|----|---|
| 1 | pH/ORP sensor | 9 | Canisters for cleaning and buffer solutions |
| 2 | Assembly Cleanfit | 10 | Superheated steam/water/cleaning solutions (optional) |
| 3 | Transmitter Mycom S CPM153 | 11 | Rinse block |
| 4 | Special measuring cable | 12 | Rinse water valve |
| 5 | Communication and extension cables | 13 | Power/signal cable |
| 6 | Power supply Mycom | 14 | Air hoses |
| 7 | Power supply CPG310 | 15 | Medium |
| 8 | Control unit CPG310 | | |

Installation

Installation instructions

- | | | |
|---|-------------------------|--|
| A | Glass electrode: | Installation angle of at least 15° from the horizontal |
| B | ISFET pH-sensor Tophit: | No restrictions, recommended 0 ... 180° |

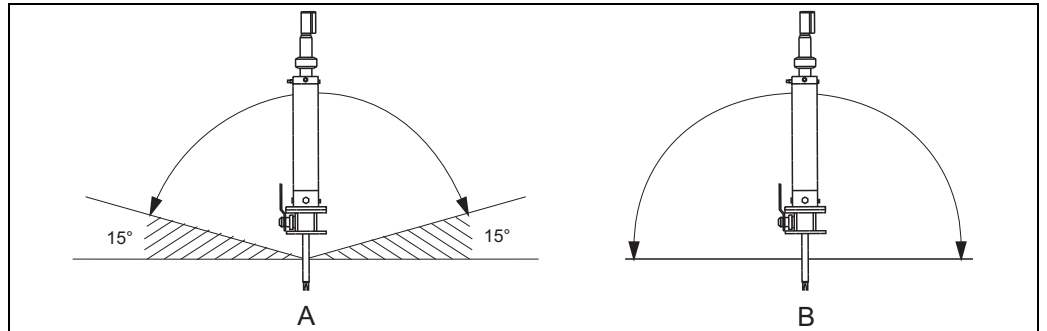

Permitted orientations depending on the sensor used

Caution!

- For all assemblies with stainless steel pressure cylinders, we recommend to use a flanged version when installing with inclined orientation. Otherwise, the weight of the assembly could affect the safety of the process connection.
- Avoid a siphon effect¹⁾ at the rinse chamber outlet when installing with inclined orientation. The inlet to the rinse chamber must be from below.

Pneumatic connections for automatic operation

Requirements:

- air pressure of 4 to 6 bar (58 to 87 psi)
- air must be filtered (40 µm) and be free of water and oil
- no continuous air consumption
- minimum nominal diameter of the air lines: 4 mm (0.16 ")

Connection thread: 2 x G 1/8

Note!

There must be a pressure-reducing valve upstream if the air pressure can increase to above 6 bar (87 psi) (including any short pressure surges).

To ensure a smooth assembly operation the assembly is equipped with a pneumatic throttle.

Environment

Ambient temperature range

Ambient temperature not below 0 °C (32 °F).

With an optional inlet/outlet safety seal, the ambient temperature may not exceed 80 °C (176 °F).

1) Siphon effect: line emptied by vacuum

Process

Pressure		
PA pressure cylinder:		Max. 6 bar (87 psi)
Stainless steel pressure cylinder:		Max. 10 bar (145 psi)
Pneumatic outlet safety seal:		Continuous operation: 6 bar (87 psi) / 100 °C (212 °F), short-term (max. 1 h): 5 bar (72.5 psi) / 140 °C (264 °F)
Manual outlet safety seal:		6 bar (87 psi) / 20 °C (68 °F), 2 bar (29 psi) / 130 °C (265 °F)
Ball valve:		max. 16 bar (232 psi), 130 °C (266 °F)
Assembly in service position (ball valve is closed)		
Caution!		
The process pressure may not exceed 4 bar (58 psi) with manually actuated assemblies!		

Temperature		
PA pressure cylinder (manually only):		Max. 80 °C (176 °F)
Stainless steel pressure cylinder:		Up to 100 °C (212 °F) with continuous operation up to 6 bar (87 psi); short-term (max. 1 h): max. 140 °C (264 °F) at 5 bar (72.5 psi) max. 100 °C (212 °F) at 10 bar (145 psi)

Pressure-temperature diagram

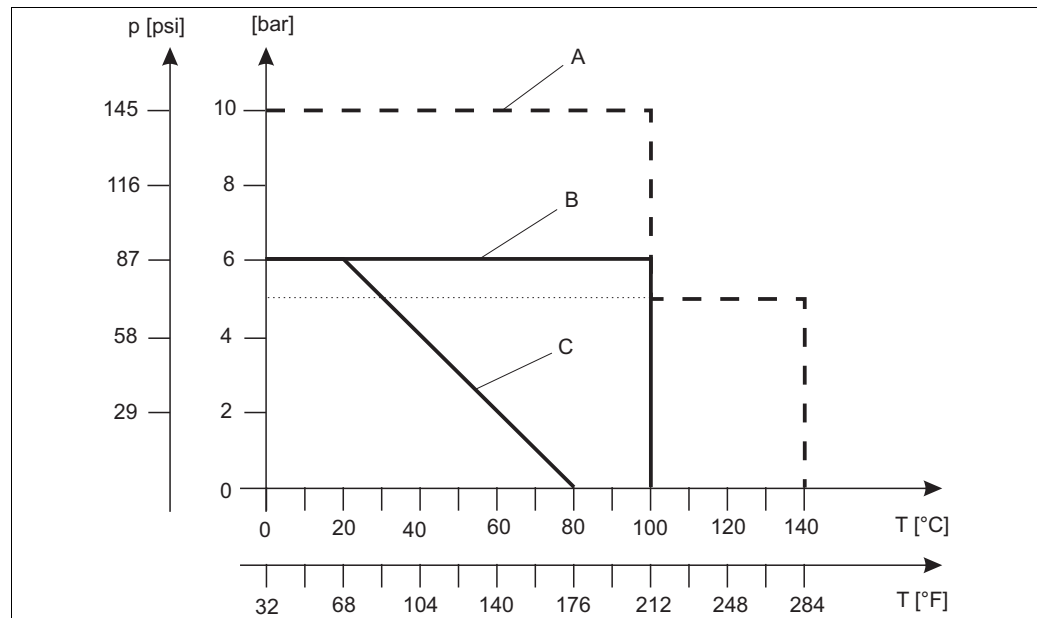

Fig. 1: Pressure-temperature diagram depending on the assembly material

- B Pressure cylinder (assembly) stainless steel 1.4404 (AISI 316L), short-term (max. 1h)
 A Pressure cylinder (assembly) stainless steel 1.4404 (AISI 316L)
 C Pressure cylinder (assembly) PA

Flow velocity	
	Max. 3 m/s (9.8 ft/s)
Note!	
<ul style="list-style-type: none"> ■ A flow of 2 to 3 m/s (6.5 to 9.8 ft/s) should not be exceeded as otherwise measurable potentials can develop at the electrode. ■ Within the permitted limits, mechanical stability does not depend on temperature and immersion depth. 	

Mechanical construction

Design, dimensions

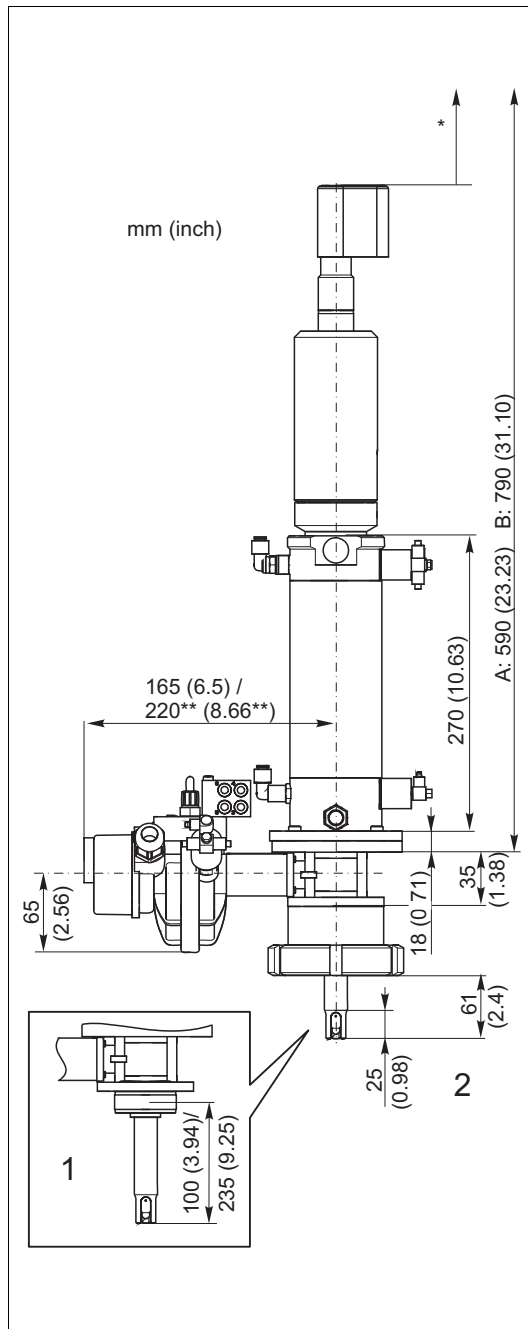

Version: pneumatic, short, for KCl sensors

- 1 G1/4, short version / long version
- 2 With dairy fitting there is only a short version!
- * Stroke
- ** Version with electric limit position switches

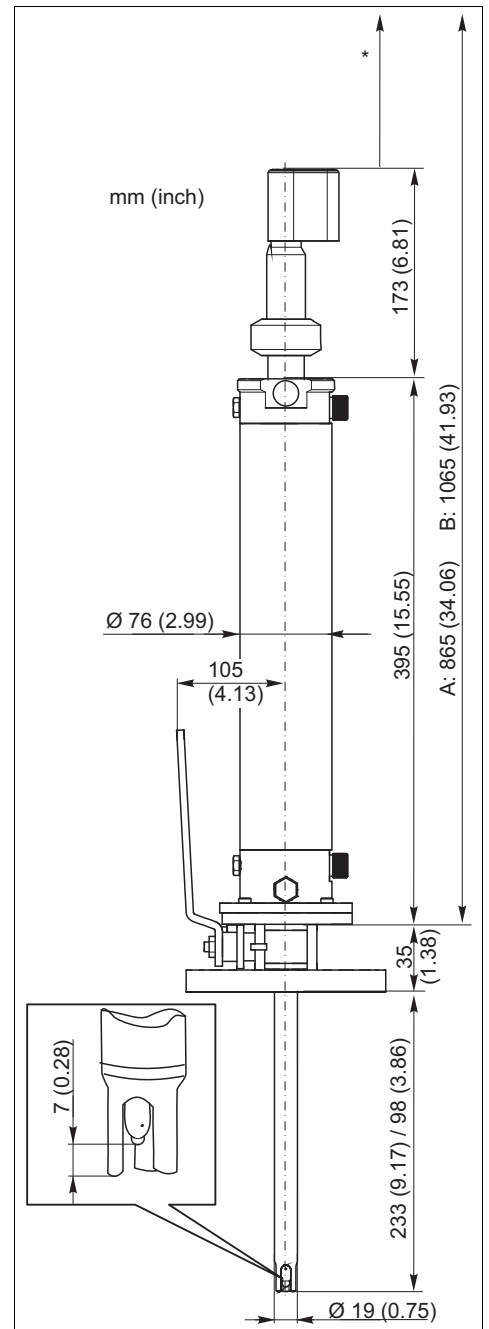

Version: manual, long, for gel sensors, flange

- long version / short version
- A Assembly in service position
- B Assembly in service position plus required mounting clearance
- * Stroke

Process connection

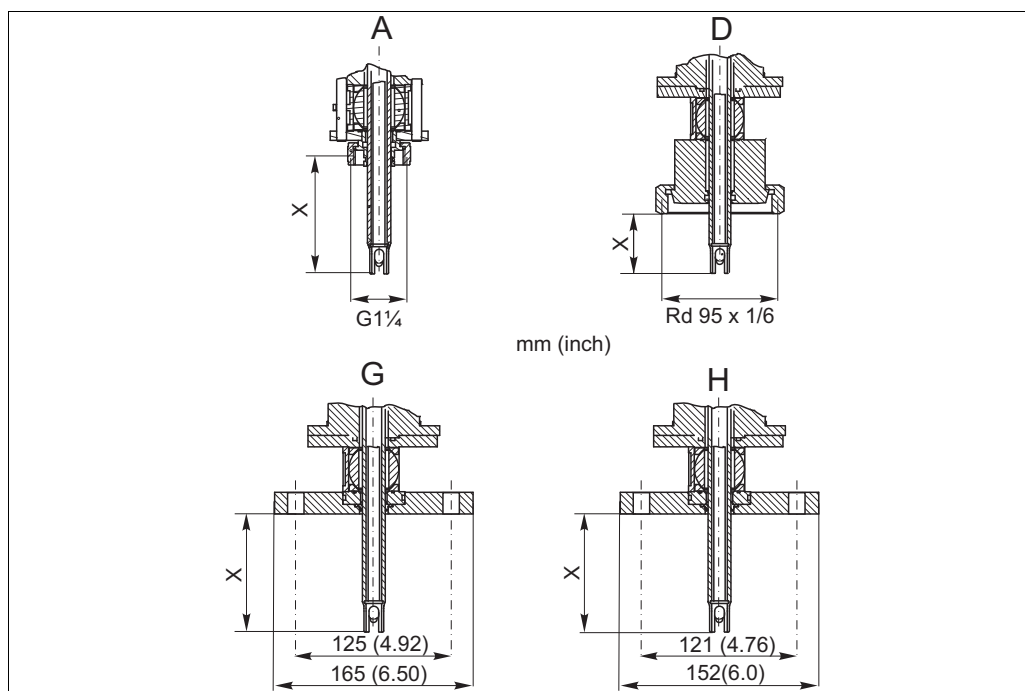

Process connections

Process connection		X short version	X long version
A	G1/4 internal thread	100 mm (3.94")	235 mm (9.25")
D	Dairy fitting DN 65	61 mm (2.40")	not available
G	Flange DN 50	98 mm (3.86")	233 mm (9.17")
H	Flange ANSI 2"	98 mm (3.86")	233 mm (9.17")

Fitted sensors

Short version	pH glass electrodes, Gel 225 mm (8.9") pH glass electrodes, KCl 425 mm (16.7") pH ISFET sensors, Gel, 225 mm (8.9") pH ISFET sensors, KCl, 425 mm (16.7")
Long version	pH glass electrodes, Gel, 360 mm (14.2") pH ISFET sensors, Gel, 360 mm (14.2")

Weight

4 to 15 kg (8.8 to 33.1 lb), depending on the pressure cylinder material, the process connection, the drive and additional equipment, see product structure.

Materials

In contact with medium:	
Seals	EPDM / FPM / perfluoroelastomer
Electrode holder	Stainless steel 1.4404 (AISI 316L), electro-polished
Ball valve	Stainless steel 1.4401 / 14408(AISI 316 / CF-8M), PTFE
Inlet safety seal	PVDF, PTFE, Viton®
Outlet safety seal	PVDF, Stainless steel 1.4404 (AISI 316L)
Rinse connection socket	Stainless steel 1.4404 (AISI 316L)
Not in contact with medium:	
Pressure cylinder	PA / stainless steel 1.4404 (AISI 316 L)
El. limit position switch	fore-part PBT, cable PVC

Rinse fittings

2 x G1/4 (internal) or
2 x NPT 1/4" (internal)

Rinse chamber inlet and outlet safety seals

Optionally the assembly is supplied with a non-return valve on the inlet side of the rinse chamber (inlet safety seal) and an outlet valve (pneumatic outlet safety seal) resp. a ball valve (manual outlet safety seal, see product structure).

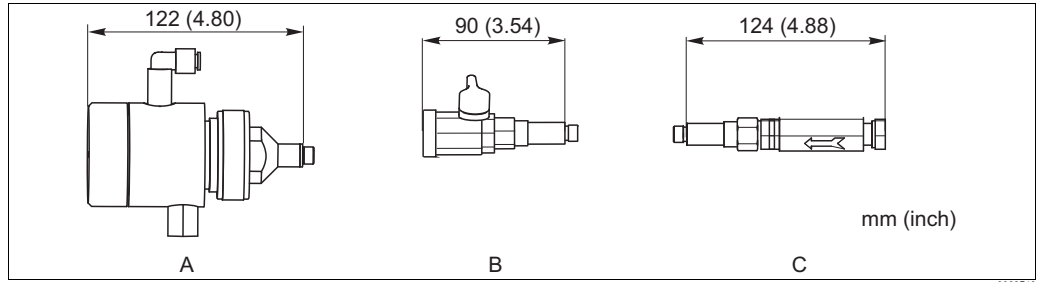

Inlet / outlet safety seals for rinse chamber

- A Pneumatic outlet safety seal
- B Manual outlet safety seal (plastic version)
- C Non-return valve (inlet safety seal)

A manual outlet safety seal (stainless steel) is available as accessory.

Caution!

An outlet safety seal is definitely required if the rinse chamber does not remain sealed with the drain plug²⁾.

Inlet safety seal (optionally)

The non-return valve prevents medium from penetrating from the rinse chamber into the rinse water inlet.

Pneumatic outlet safety seal (optionally)

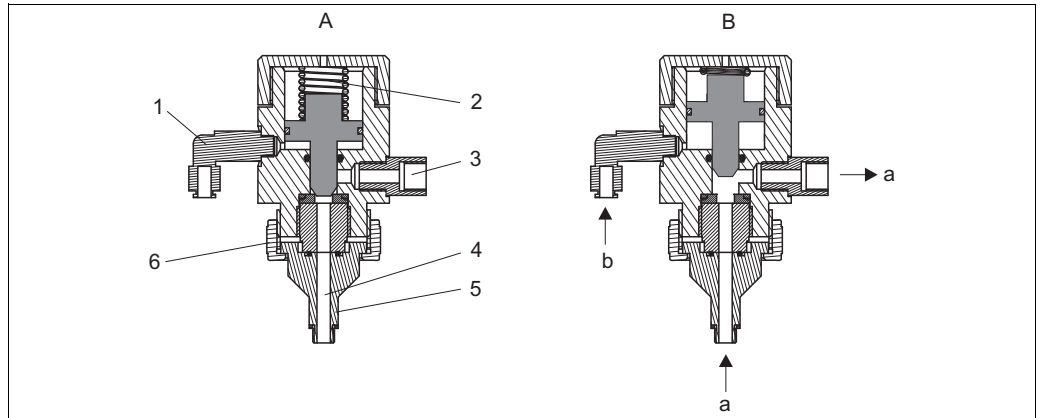

Functional diagram of the pneumatic valve on the outlet side of the rinse chamber

- A: Valve closed (no connection between rinse water and rinse chamber)
- B: Valve open (rinse water can enter rinse chamber)

- | | |
|---------------------------------|---------------------------|
| 1 Compressed air input | 5 Rinse connection socket |
| 2 Compression spring | 6 Union nut G 1 1/4 |
| 3 Rinse water outlet | a Rinse water |
| 4 Outlet from the rinse chamber | b Compressed air |

Manual outlet safety seal (optionally)

The manual safety seal is a ball valve made of PVDF. You have to drive it manually.

2) also applies in "Measure" position

PEEK scraper ring

The scraper rings are especially recommended in the following cases:

- If the rinse chamber, otherwise open to the process, should be protected during operation.
- If material sticking to the electrode holder (caused by the medium) should be scraped off when moving to service mode.

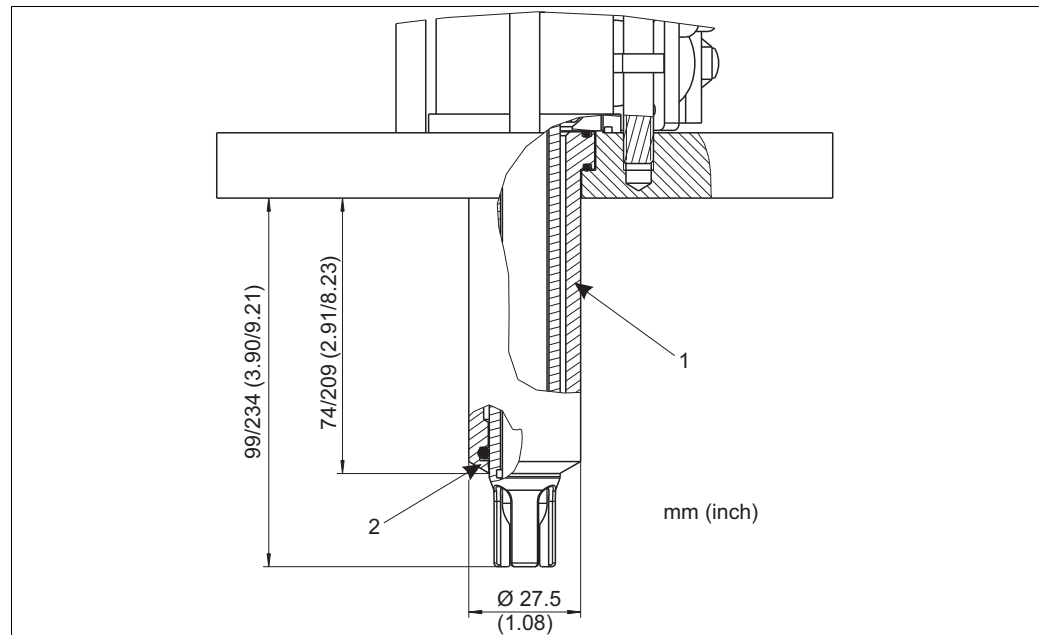

Packing sleeve (short/long immersion depth)

- 1 Sleeve (PEEK)
2 Scraper

Ball valve

DN 25 type: FP3

Material:	1.4408 (AISI CF-8M), PTFE fiber-glass reinforced
Shaft seal:	3x piston ring clamp made of PTFE/graphite
Manually operated	Hand lever
Pneumatically operated	Kinetrol® part-turn valve actuator, rotor principle
	Housing: zinc cast alloy
	Epoxy-coated bearing surface

Limit position switches

Pneumatic:	3/2 way valve; thread M 12 x 1; connection for hoses with OD = 6 mm (0.24")
Electric:	inductive (NAMUR type); cable length: 10 m (32.8 ft); housing material: stainless steel; thread M 12 x 1; nominal voltage: 8 V ⓈII 1G EEx ia IIC T6; switching distance: 2 mm, flush

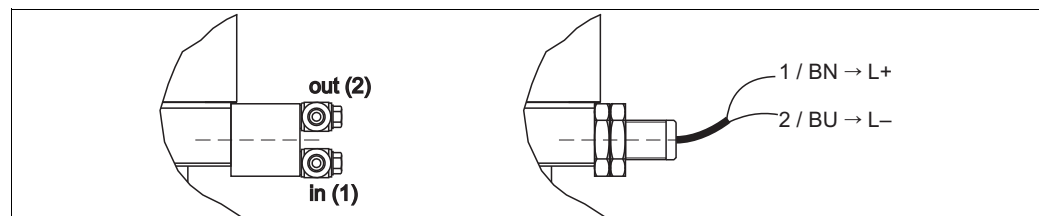

Limit position switches, left: pneumatic (1 = compressed air inlet, 2 = compressed air outlet) right: electric (NAMUR)

Note!

The position of the input resp. the output may be different from the figure. Please, refer to the marks at the limit position switch: "1" is the input (in), "2" is the output (out).

Certificates and approvals

Test reports

Depending on the version, an inspection certificate 3.1 acc. to EN 10204 is supplied (-> product structure).

Ordering information

Scope of delivery

The scope of delivery comprises:

- Cleanfit assembly (ordered version)
- Operating Instructions (English)

Product structure

Assembly drive, ball valve									
A									Assembly + ball valve: manual (convertable to pneumatic only with stainless steel pressure cylinder)
B									Assembly: pneumatic, ball valve: manual, without limit position switches (retrofitable)
C									Assembly: pneumatic, ball valve: manual, with pneumatic limit position switches
D									Assembly: pneumatic, ball valve: manual, with electric limit position switches (Ex and Non-Ex)
E									Assembly + ball valve: pneumatic, with pneumatic limit position switches
F									Assembly + ball valve: pneumatic, with electric limit position switches (Ex and Non-Ex)
Y									Special version acc. to customer specification
Assembly version									
									1 Max. 80 °C (176 °F), max. 6 bar (87 psi), with PEEK scraper (PA cylinder)
									2 Heavy duty version: max. 140 °C (284 °F), max. 6 bar (87 psi), with PEEK scraper (SS cylinder)
									3 Max. 80 °C (176 °F), max. 6 bar (87 psi), without PEEK scraper, i.e. the rinse chamber is not sealed off the medium! (PA cylinder)
									4 Heavy duty version: max. 140 °C (284 °F), max. 6 bar (87 psi), without PEEK scraper, i.e. the rinse chamber is not sealed off the medium! (SS cylinder)
									5 Heavy duty version: max. 140 °C (284 °F), max. 6 bar (87 psi), with PEEK scraper (SS cylinder/flange)
									9 Special version acc. to customer specification
Electrode type									
A									For gel electrodes and pH ISFET sensors with Pg 13.5 (length: 225 mm (8.9") or 360 mm (14.2"))
B									For liquid KCl electrodes and ISFET sensors with Pg 13.5 and hose connection head (type ESS) (425 mm)
Y									Special version acc. to customer specification
Immersion depth									
									1 Short version up to 100 mm (3.94") with PA cylinder (possible sensor lengths: type A = 225 mm (8.9"), type B = 425 mm (16.7")) Assembly versions 1 and 3 only!
									2 Short version up to 100 mm (3.94") with stainless steel 1.4404 (AISI 316L) cylinder (possible sensor lengths: type A = 225 mm (8.9"), type B = 425 mm (16.7")) Assembly versions 2 and 4 only!
									3 Long version up to 235 mm (9.25") with PA cylinder (possible sensor lengths: type A = 360 mm (14.2")) Assembly versions 1 and 3 only!
									4 Long version up to 235 mm (9.25 inches) with stainless steel 1.4404 (AISI 316L) cylinder (possible sensor lengths: type A = 360 mm (14.2")) Assembly versions 2, 4 and 5 only!
									9 Special version acc. to customer specification
Assembly material (in contact with medium)									
A									Stainless steel 1.4404 (AISI 316L)
B									Stainless steel 1.4404 (AISI 316L) with test certificate 3.1 acc. to EN 10204
Y									Special version acc. to customer specification
Seal material (in contact with medium)									
									1 EPDM (for food applications preferred)
									2 FPM (Viton®, for process applications preferred)
									3 Perfluoroelastomer (KALREZ®)
									9 Special version acc. to customer specification
Process connection									
A									Internal thread G 1 ¼ with thread adapter nut
D									Dairy fitting DN 65 (DIN 11851) For flow assembly CPA240 (immersion depths 1 and 2 only!)
G									Flange DN 50, PN 16
H									Flange ANSI 2", 150 lbs
Y									Special version acc. to customer specification
Optional equipment									
									3 With pneumatic inlet/outlet safety seal (2 x G ¼ internal thread / PVDF safety plug)
									4 With pneumatic inlet/outlet safety seal (2 x NPT ¼" internal thread / PVDF safety plug)
									5 With manual inlet/outlet safety seal (2 x G ¼ internal thread / PVDF safety plug)
									6 With manual inlet/outlet safety seal (2 x NPT ¼" internal thread / PVDF safety plug)
									7 With rinse connection sockets, 2 x G ¼ internal thread (version 1, 2 only!) (with PVDF safety plug)
									8 With rinse connection sockets 2 x NPT ¼" internal thread (version 1, 2 only!) (with PVDF safety plug)
									9 Special version acc. to customer specification
CPA473-									complete order code

Accessories

Note!

In the following sections, you find the accessories available at the time of issue of this documentation.
For information on accessories that are not listed here, please contact your local service or sales representation.

Process adapter

Built-in adapter DN 25

- Stainless steel 1.4404
- "Straight" version - Order No.: 51500328
- "Inclined" version - Order No.: 51500327

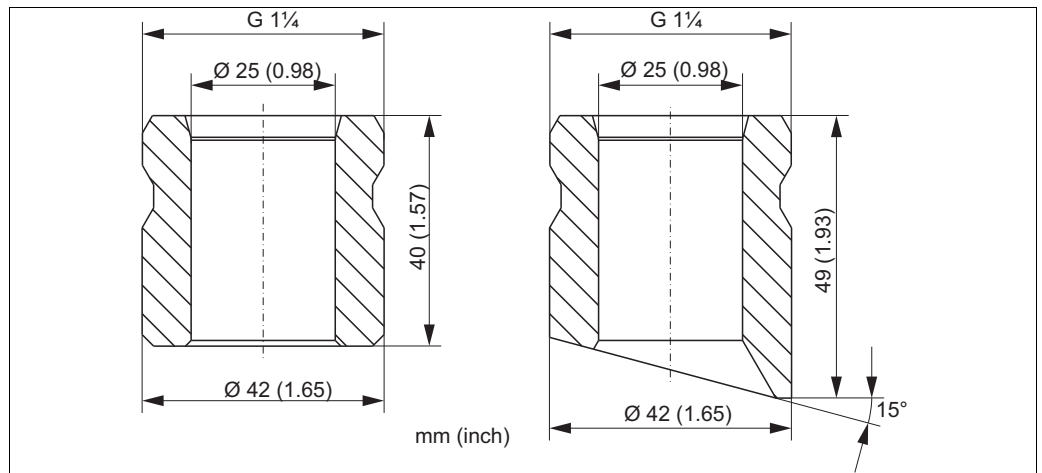

G 1/4 built-in adapter, straight and inclined

Welded fitting DN 50 (70 mm), inclined, material: 1.4571 (AISI 316 Ti);

- order no. 71098682

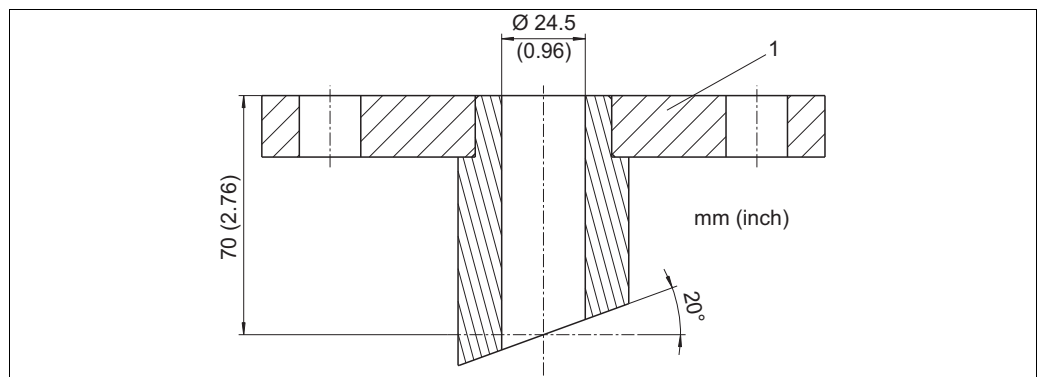

Welded fitting

1 Flange DN 50 / PN16

Water filter and pressure reducer

Filter set CPC310

- Water filter (dirt trap) 100 µm, complete, incl. angle bracket;
- Order no. 71031661

Pressure reducer kit

- Complete, incl. manometer and angle bracket;
- Order no. 51505755

Pneumatic throttle for the reduction of the assembly moving speed,

- G1/8 threaded connection
- order no. 50036864

Rinse connection adapter

- Rinse connection adapter CPR40 for connecting 2 or 4 different media.
Order acc. to product structure, see Technical Information (TI342C/07/en).

Inlet / outlet safety seal

Pneumatic outlet safety seal for rinse chamber outlet

- G ¼, order no. 51511929
- NPT ¼", order no. 51511934

Manual outlet safety seal for rinse chamber outlet

- G ¼, order no. 51511937
- NPT ¼", order no. 51511938

Manual outlet safety seal for rinse chamber

- Ball valve, stainless steel 1.4408 (AISI CF-8M)
- G ¼, order no. 71083041

Non-return valve (inlet safety seal) for rinse chamber inlet

- G ¼, order no. 51511939
- NPT ¼", order no. 51511940

Hose connections for rinse chamber

- Hose connection set, for Cleanfit assemblies, PVDF, G ¼, D12 order no. 51511724
- Hose connection set, for Cleanfit assemblies, stainless steel 1.4404 (AISI 316L), NPT ¼", D12 order no. 51511725
- Hose connection set, for Cleanfit assemblies, PVDF, NPT ¼", D12 order no. 51511726
- Hose connection set, for Cleanfit assemblies, stainless steel 1.4404 (AISI 316L), NPT ¼", D16 order no. 51511722
- Hose connection set, for Cleanfit assemblies, PVDF, NPT ¼", D16 order no. 51511723
- Hose connection set, for Cleanfit assemblies, stainless steel 1.4404 (AISI 316L), G ¼, D16 order no. 51511590
- Hose connection set, for Cleanfit assemblies, PVDF, G ¼, D16 order no. 51511591

Limit position switches

Set of pneumatic limit position switches (2 pieces);

- order no. 51502874

Set of electric limit position switches, Ex and non-Ex (2 pieces);

- order no. 51502873

Sensors**Glass electrodes**

Orbisint CPS11/CPS11D

- pH sensor for process applications
- Optionally with Memosens technology
- With PTFE diaphragm
- Ordering acc. to product structure, see Technical Information (TI028C/07/en)

Orbisint CPS12/CPS12D

- ORP electrode for process applications
- Optionally with Memosens technology
- With PTFE diaphragm
- Ordering acc. to product structure, see Technical Information (TI367C/07/en)

Ceraliquid CPS41/CPS41D

- pH sensor
- Optionally with Memosens technology
- With ceramics diaphragm and liquid KCl electrolyte
- Ordering acc. to product structure, see Technical Information (TI079C/07/en)

Ceraliquid CPS42/CPS42D

- ORP electrode
- Optionally with Memosens technology
- With ceramics diaphragm and liquid KCl electrolyte
- Ordering acc. to product structure, see Technical Information (TI373C/07/en)

Ceragel CPS71/CPS71D

- pH sensor
- Optionally with Memosens technology
- With double chamber reference system and integrated bridge electrolyte
- Ordering acc. to product structure, see Technical Information (TI245C/07/en)

Ceragel CPS72/CPS72D

- ORP electrode
- Optionally with Memosens technology
- With double chamber reference system and integrated bridge electrolyte
- Ordering acc. to product structure, see Technical Information (TI374C/07/en)

Orbipore CPS91/CPS91D

- pH sensor
- Optionally with Memosens technology
- With open aperture for media with high dirt load
- Ordering acc. to product structure, see Technical Information (TI375C/07/en)

ISFET sensors

Tophit CPS471/CPS471D

- Sterilizable and autoclavable ISFET sensor for food and pharmaceuticals, process technology, water treatment and biotechnology;
- Ordering acc. to product structure, see Technical Information (TI283C/07/en)

Tophit CPS441/CPS441D

- Sterilizable ISFET sensor for media with low conductivity, with liquid KCl electrolyte;
- Ordering acc. to product structure, see Technical Information (TI352C/07/en)

Tophit CPS491/CPS491D

- ISFET sensor with open aperture for media with high dirt load;
- Ordering acc. to product structure, see Technical Information (TI377C/07/en)

Transmitters

Liquiline M CM42

- Modular two-wire transmitter, stainless steel or plastic, field or panel instrument
- Various Ex approvals (ATEX, FM, CSA, Nepsi, TIIS)
- HART, PROFIBUS or FOUNDATION Fieldbus available
- Ordering acc. to product structure, see Technical Information (TI381C/07/en)

Liquisys M CPM223/253

- Transmitter for pH and ORP, field or panel-mounted housing
- HART or PROFIBUS available
- Ordering acc. to product structure, see Technical Information (TI194C/07/en)

Mycom S CPM153

- Transmitter for pH and ORP, one or two channel version, Ex or non-Ex
- HART or PROFIBUS available
- Ordering acc. to product structure, see Technical Information (TI233C/07/en)

Measuring, cleaning and calibration systems

Topcal S CPC310

- Fully automatic measuring, cleaning and calibration system; Ex or non-Ex
- In-situ cleaning and calibration, automatic sensor monitoring
- Ordering acc. to product structure, Technical Information TI404C/07/en

Topclean S CPC30

- Fully automatic measuring and cleaning system; Ex or non-Ex
- In-situ cleaning, automatic sensor monitoring
- Ordering acc. to product structure, see Technical Information TI235C/07/en

International Headquarters

Endress+Hauser
Instruments International AG
Kaegenstr. 2
4153 Reinach
Switzerland

Tel. +41 61 715 81 00
Fax +41 61 715 25 00
www.endress.com
info@ii.endress.com

TI344C/07/en/11.09
71073259
Printed in Germany / FM+SGML 6.0 / DT