

Level Limit Switch Liquiphant FailSafe liquiphant S FDL 60, FDL 61 nivotester FTL 670

**Fail-safe overspill protection
Vibration limit switch for all types of liquids
and for liquefied gas
Functional safety**



FDL 61



FDL 60



FTL 670

Application

- Fail-safe overspill protection of tanks with flammable liquids of all types, independent of turbulence, electrical properties, solids or air bubbles.
- Fail-safe overspill protection of tanks containing liquefied gases

The measuring system fulfils the requirements

- of functional safety:
SIL3 to IEC 61508
TÜV Certificate
No. Z 10 03 11 20351 002
and
AK5 to DIN V 19250,
TÜV Certificate
No. U 95 04 20351 001
- of suitability for liquefied gas
to VdTÜV, Sheet 100 (Germany)
- of explosion protection
with intrinsic safety (EEx ia IIC T6)
- of electromagnetic compatibility
to NAMUR recommendations.

Features and Benefits

- Continuous self-monitoring
- No calibration required
- Resistance to vibration with optimised drive unit
- Compact switching unit: Europa card 4 HP
- Follow-up units checked remotely or at the touch of a button
- Simplified troubleshooting with LED display
- According to AK5 to DIN V 19250 recurrent function test is not necessary.

Endress + Hauser

The Power of Know How



Measuring System

The measuring system consists of:

- Liquiphant S FDL 60 or FDL 61 sensor
- Nivotester FTL 670 switching unit
- Monorack II (4 HP) protective housing or assembly rack with power unit
- Other electrical devices for control or signalling (contactors, magnetic valves, alarms, etc.)

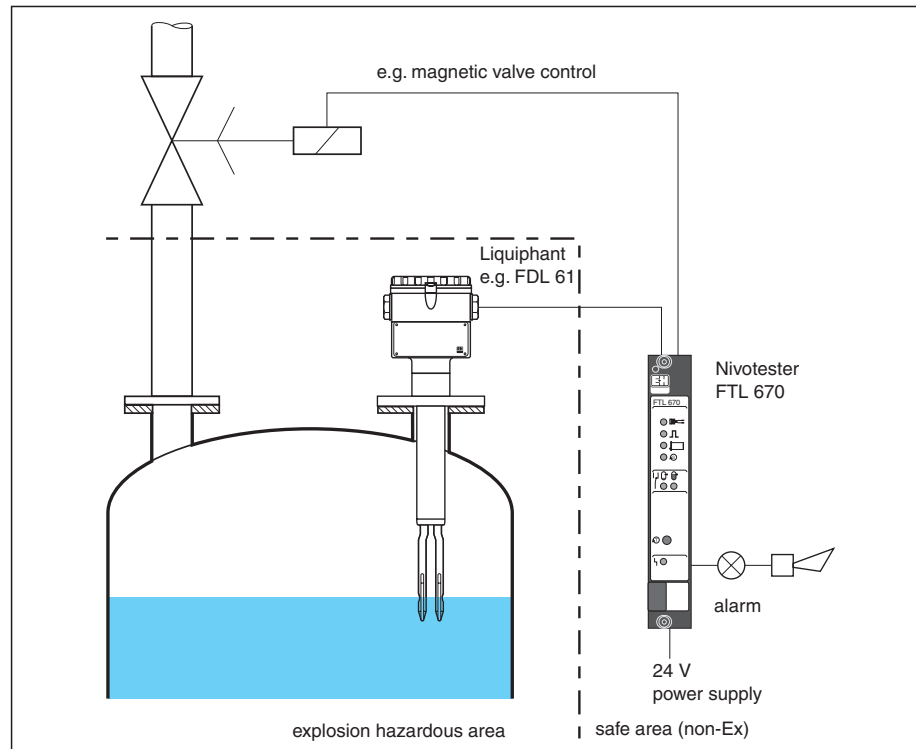

Measuring system for overspill protection

Operating Principle

Liquiphant S FDL 60, FDL 61

The fork of the Liquiphant S sensor is made to vibrate in air at its resonant frequency by piezo-electric elements. The frequency changes when the fork is submerged in a liquid. The frequency is converted to an interference-immune, pulse frequency modulated signal (PFM) and is transmitted over a two-wire cable to the Nivotester FTL 670.

The complete system has an in-built redundancy and a continuous self-checking function. The sensor has two independent electronic sensing circuits which are activated alternately. The two signals are given identification tags for correct evaluation at the Nivotester FTL 670.

Nivotester FTL 670

The Nivotester supplies the Liquiphant S with intrinsically safe power and receives from it on the same line a PFM signal (superimposed on the base current). A redundant processor system evaluates and compares the signals from the two sensing circuits.

At the same time the processors carry out an ongoing test of all safety relevant components. When the fork of the Liquiphant S is uncovered the safety contact of the switching output of the Nivotester is closed. When the fork is covered with liquid to the switch point the Nivotester breaks this potential-free output. Should a fault occur in the system or power fail, this circuit is also broken (Safety contact in quiescent maximum fail-safe mode). Faults are also indicated by a separate relay contact. For simplified fault-diagnosis three yellow LEDs indicate the fault location.

The combination of redundant sensor and evaluating circuitry, dynamic signal analysis and continuous self-checking ensures that when the switch point is reached or a fault occurs the switching output fails-to safe every time.

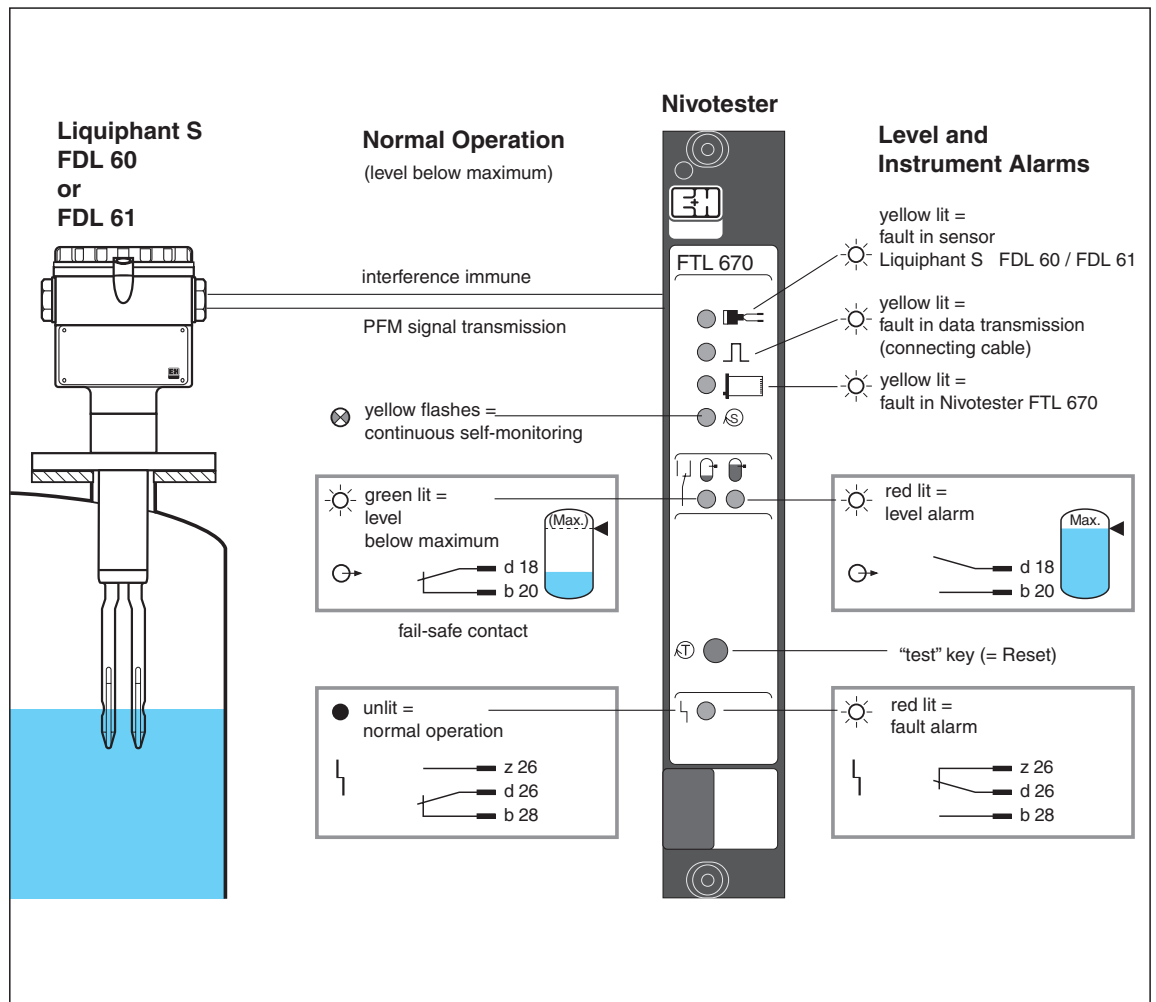

Standards and Regulations

All local (national) standards and regulations must be complied with in regard to overspill protection and explosion protection as well as all requirements given in the certificates.

See
Notes on Safety
XA 027 and XA 069
for all important data
taken from the
EC Type Approval
Test Certificate

Application	Certificate
Liquiphant S in explosion-hazardous areas	EC Type Approval Test Certificate KEMA 97 ATEX 4490, PTB 00 ATEX 2008
Liquiphant S in liquefied gases (Germany)	TÜV - Components approval to VdTÜV, Sheet 100 (Germany) TÜV ÜS.01-049.liquefied gas. PN 25 or PN 40 (Germany)
Overspill protection to WHG for waterpolluting liquids	DIBt general building authority approval Z-65.11-3

Installation

Installing the Liquiphant S FDL 60 and FDL 61

Mounting at any orientation in a tank containing liquid

- 1) FDL 61 from above
- 2) FDL 61 with sliding sleeve
- 3) FDL 60 from the side
- 4) FDL 61 from below

* ensure sufficient room for mounting!

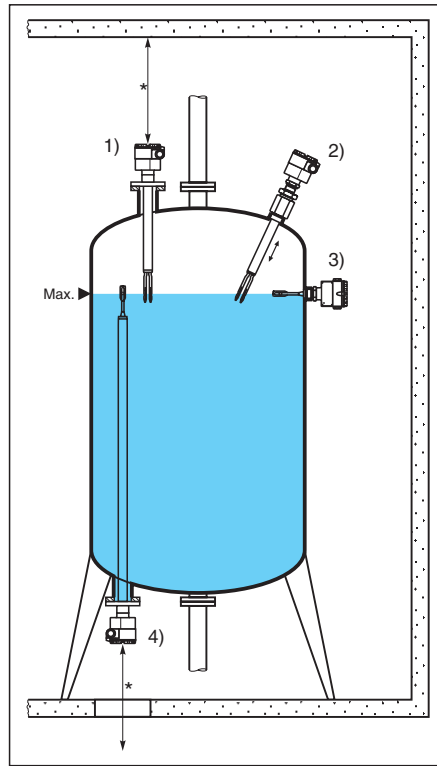

The diagrams show various installations. See the appropriate installation regulations for the different process connections.

Mounting in a liquefied gas tank

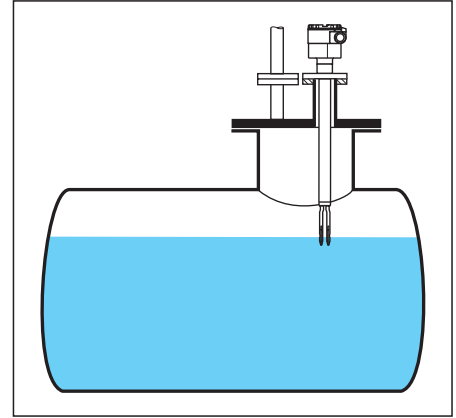

Left:
Take into account any build-up of material in the tank!

Right:
The inflowing liquid should not flow directly onto the fork

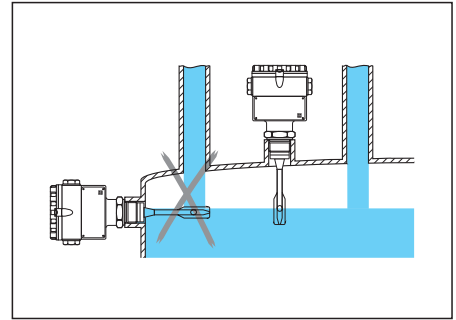
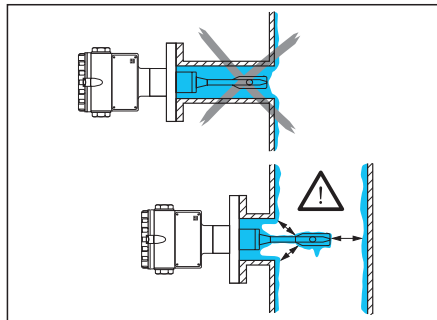

Typical values:

For water:
 s = approx. 15 mm
 density setting > 0.5,
 s = approx. 20 mm
 density setting > 0.7,
 ($T = 20^\circ\text{C}$, $p_e = 0$ bar)

For liquefied gas:
 s = approx. 30 mm
 density setting > 0.5,
 e.g. propane,
 10°C , 6.5 bar or
 20°C , 9.0 bar;
 e.g. butane, 10°C , 1.5 bar
 or 20°C , 2.0 bar.

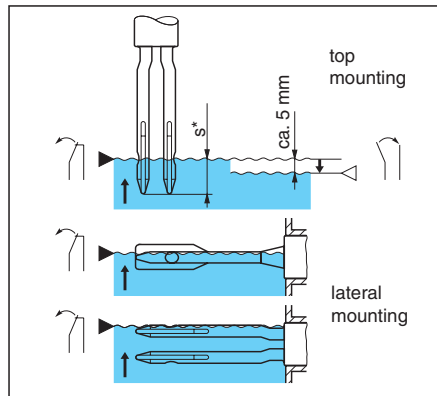

There must be sufficient clearance for the fork so that:

- highly viscous liquids quickly flow off the fork
- the fork does not come into contact with the wall of the tank or any internal fitting
- the fork does not come into contact with any build-up on the tank wall
- inflowing liquid does not flow directly onto the fork.

Also note the position of the switchpoint in the tank with regard to:

- thermal expansion of the liquid,
- final discharge when the inlet valve is shut and
- with an open-vented tank, the thickness of any foam layer, as the Liquiphant S detects the surface of the liquid and is not affected by foam.

Switchpoint as a function of mounting position

*Height s of the switchpoint above the sensor tips for vertical mounting from the top

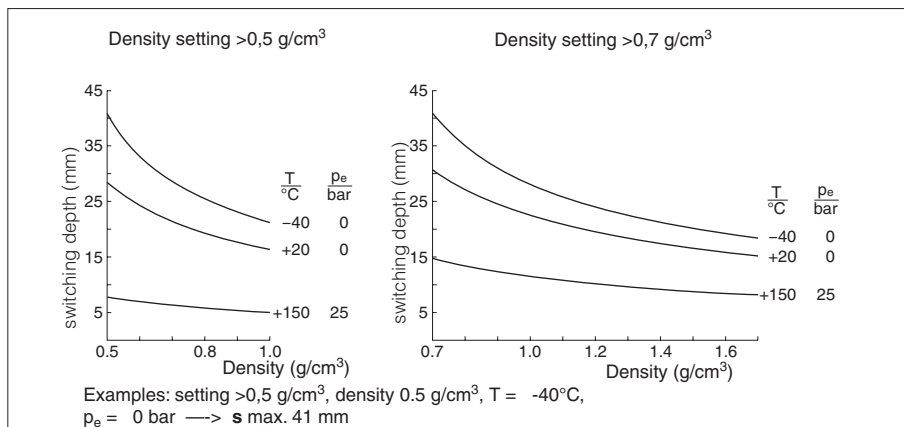

Maximum height of switching point s as a function of density and temperature

s can also be lower at higher pressures and temperatures and depending upon sensor tolerances

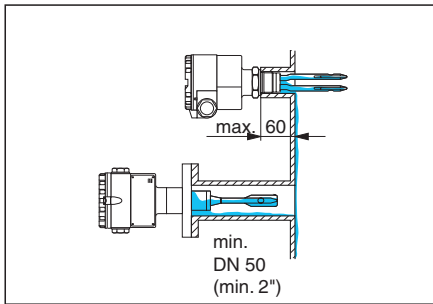

Type of installation
in viscous liquids,
viscosity ν ;

Above right:
not dependent on
viscosity

Above left:
viscosity ν
up to 2000 mm²/s

Below:
viscosity ν
above 2000 mm²/s

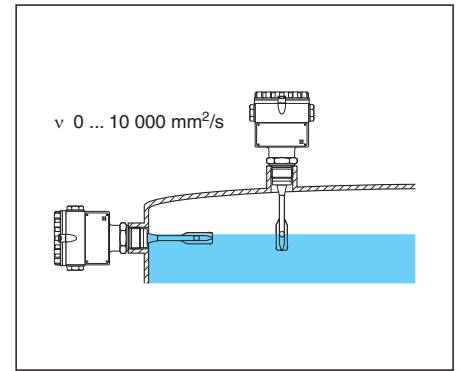
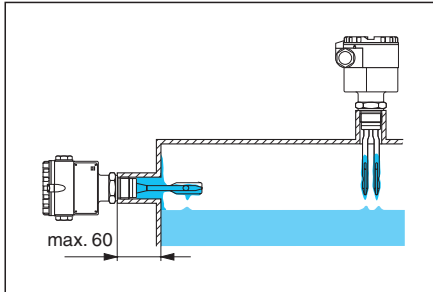

FDL 60 (short version)

The switchpoint of the Liquiphant S FDL 60 is determined by the mounting position (usually laterally on the tank).

FDL 61 (with extension tube)

For a Liquiphant FDL 61 mounted from above, the length L required is calculated from the:

- distance from the upper edge of the tank process connection to the switchpoint at the surface of the liquid
- + "s" mm (see Page 4)
- + tolerances in length (see Page 8)
- + accessory, e.g. sealing, sandwich flange.

For a Liquiphant S FDL 61 with high pressure sleeve, the switchpoint can be adjusted to the millimetre when commissioning.

Installing the Liquiphant S FDL 61

- 1) with thread-connection G 1 or 1" NPT
- 2) with flange connection from DN 32
- 3) with sliding sleeve G 1 1/2 or 1 1/2" NPT

* position of switchpoint s, see Page 4

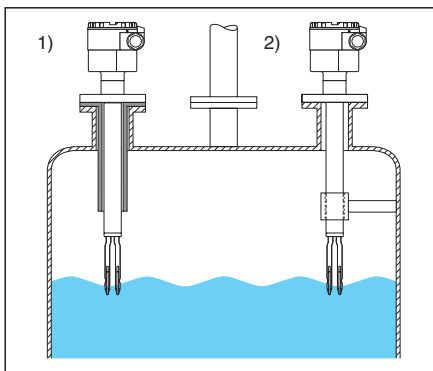
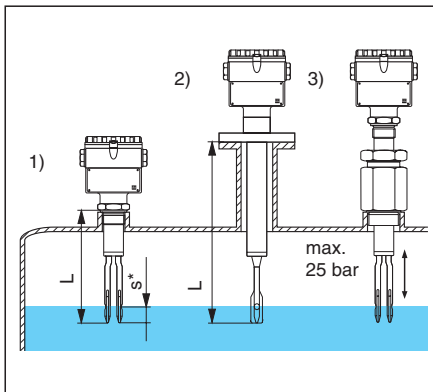

Installation with heavy
dynamic load:

- 1) FDL 61 with supporting tube (accessory)
- 2) FDL 61 with side support

If a long Liquiphant S FDL 61 is subject to strong and continuous load, e.g. due to vibration of the tank or liquid surges by agitator blades, then the extension tube should be supported.

For humid environments and cold media, to avoid condensate forming within the housing:

- Insulate the housing
- or
- Install a FDL 61, min. length 301 mm

Installing the Nivotester FTL 670

Installation and Environmental Conditions

The Nivotester FTL 670 switching unit (Racksyst plug-in card) must be installed outside the explosion hazardous area in a Monorack II housing or in an assembly rack.

A protective housing with IP55 is available for mounting the field, e.g. Monorack-protective housing or Racksyst field housing.

See Section "Supplementary Documentation".

Installing the Liquiphant in Explosion Hazardous Areas

If the Liquiphant S is to be installed in an explosion hazardous area and the Nivotester in an assembly rack *not* supplied by Endress+Hauser, then a suitable female multipoint connector should be ordered for the Nivotester FTL 670. See Technical Data.

If no parts supplied by E+H are used, then local explosion protection regulations for installation and connection of the Nivotester must be strictly observed.

Connection

Connection;
view of the connection
side of the multipoint
connector for
the Nivotester FTL 670

**
overvoltage protector
if required

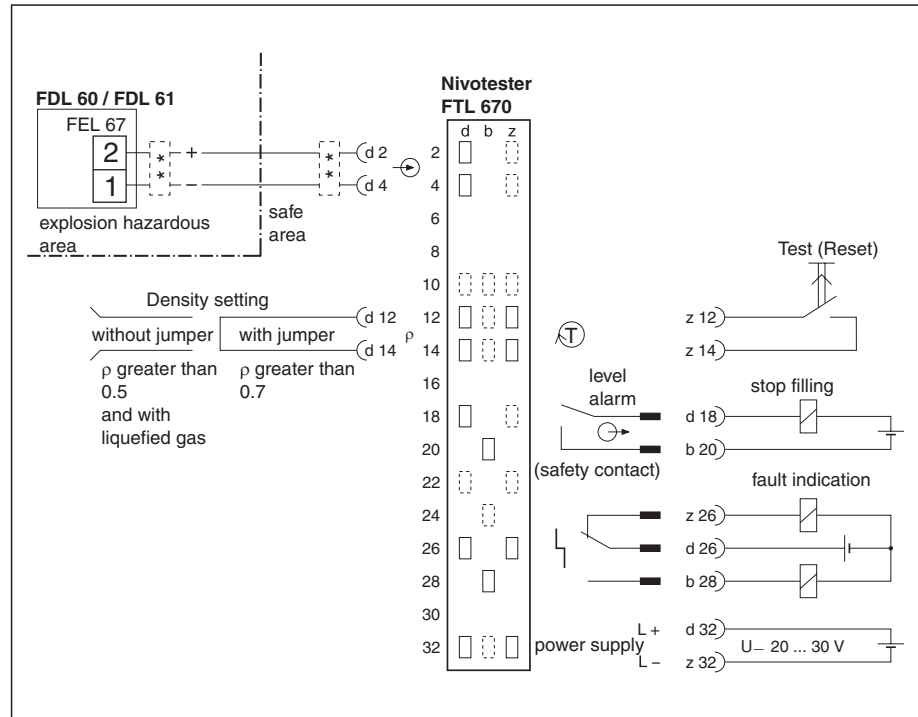

Connecting the Liquiphant S to the Nivotester

The two-wire connecting cable between the FEL 67 electronic insert in the Liquiphant S FDL 60 or FDL 61 and the Nivotester FTL 670 can be either standard unscreened or screened installation cable or two wires in a standard multicore cable.

Observe all local regulations covering explosion protection when selecting, laying and grounding intrinsically safe signal cabling.

Max. permissible values for capacitance and inductance are given in the certificate of conformity.

If voltage peaks or surges are to be expected on the signal line, e.g. because it runs outdoors, we recommend that an overvoltage protector, e.g. HAW 262 be installed in the signal line immediately before both the Liquiphant and the Nivotester. For connections, see the Technical Information sheet of the overvoltage protector.

Test (Reset)

A switch for remote control of the test procedure can be connected to Terminals z 12 and z 14 to run in parallel with the "Test" key on the front panel.

Density Setting

A correct density setting is critical for operational safety.

- For liquefied gas: do not short-circuit Terminals d 12 and d 14.
- For liquids with a density ρ 0.5 ... 0.7: do not short-circuit Terminals d 12 and d 14.
- For liquids with a density ρ *greater than* 0.7:

Connect a jumper between Terminals d 12 and d 14 of the Nivotester multipoint connector or Monorack terminal strip.

This ensures that the measuring system is *more insensitive to build-up of material*.

Level Alarm

The level alarm is fail-safe to SIL3, IEC 61508 and Requirement Class AK 5, DIN V 19250.

If the level in the tank exceeds the limit, then the potential-free contact between Terminals d 18 and b 20 (fail-safe contact) opens.

The contact also opens on an instrument alarm or on loss of power.

Follow-up control devices should therefore be connected so that they are in the fail-safe position when this contact opens.

Instrument Alarm

On an instrument alarm or loss of power the contact between Terminals d 26 and b 28 opens and the contact between Terminals d 26 and z 26 closes.

Connect follow-up devices for fault indication as is usual in your plant.

Technical Data

Operational Safety of the Measuring System

- Error safety:
SIL3 to IEC 61508 and Requirement Class AK 5 to DIN V 19250
- Explosion protection:
Intrinsic safety EEx ia IIC T6
ATEX II 1/2 G, EEx ia IIC T6

- Electromagnetic Compatibility:
Interference Emission to EN 61326;
Electrical Equipment Class B
Interference Immunity to EN 61326;
Annex A (Industrial) and
NAMUR Recommendation NE 21 (EMC)
For general information on EMC
(test methods, installation hints)
see TI 241F/00/en
- See certificates for further information

Technical Data for Liquiphant S FDL 60, FDL 61

Operating Data

- Operating temperature and pressure:
see figure below
- Viscosity ν of product:
max. 10 000 mm²/s
- Minimum density ρ of liquid:
0.5, switchable to 0.7
- Minimum density ρ of liquefied gas to
DIN 51622: 0.44
- Switching hysteresis: approx. 5 mm
- Ambient temperature for housing:
see figure below.
- Climatic class to DIN 40040: GSD

Materials

Wetted parts:

- Process connection and fork:
see Product Structure
 - Sealing ring for process connection
G 1: elastomer-thread, asbestos-free,
resistant to oils, solvents, steam, weak
acids and lyes
 - Packing of pressure screw in the
sliding sleeve: graphite
- #### External process parts:
- Aluminium housing: GD-Al Si 12 Mg,
DIN 1725, with blue plastic coating
 - Plastic housing: fibre-glass reinforced
polyester (blue)
 - Seal for housing cover:
O-ring in EPDM (elastomer)
 - Cable gland IP66 for cable entry
Pg 16: polyamide with neoprene CR
seal for cable diameters 7 ... 12 mm

The maximum permissible pressure in the tank p_e is a function of the medium and the temperature T_2 in the tank

Shaded area:
liquefied gas to
DIN 51622
and liquid
density range > 0.5

Total area:
liquids of all types
density range > 0.7

* maximum pressure
with sliding sleeve:
25 bar

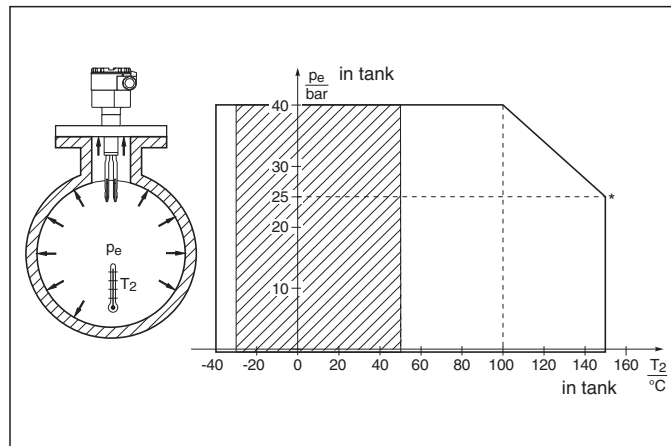

1 bar = 14.5 psi
x°C (1.8 x + 32)°F

The maximum permissible temperature T_1 at the housing is a function of the operating temperature T_2 in the tank

* limit values for
liquefied gas to
DIN 51622

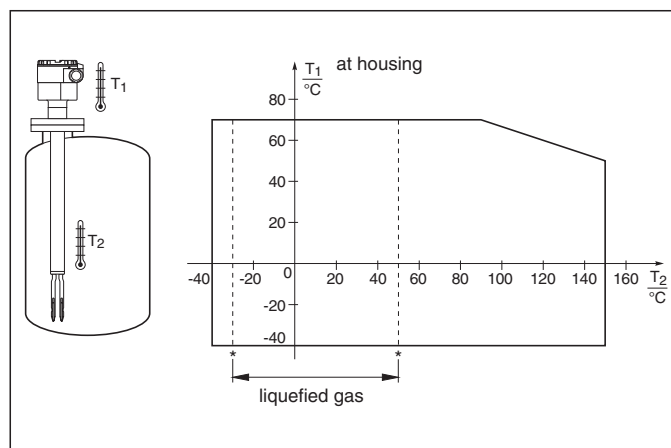

Process Connection Standards

- Parallel thread G 1 A:
DIN ISO 228/1, with flat sealing ring
33 x 39 to DIN 7603
- Parallel thread G 1 1/2 A (sliding
sleeve): DIN ISO 228/1, with flat sealing
ring 48 x 55 to DIN 7603
- Tapered thread 1 - 1 1/2 NPT:
ANSI B 1.20.1
- Tapered thread 1 1/2 - 1 1/2 NPT
(sliding sleeve): ANSI B 1.20.1
- DIN flanges: see table
- ANSI flanges: ANSI B 16.5
- JIS flanges: JIS B 2210 (RF)
- Triclamp connection 2": ISO 2852
- Sanitary thread DN 50:
DIN 11851

Electronic Insert

- Integrated electronic insert: FEL 67,
plug-in, replaceable without calibration
- Switching unit:
Nivotester FTL 670
- Connection terminals:
for max. 2.5 mm² strands with end
sleeves A 2.5 - 7 to DIN 46228
- Power supply: from Nivotester
- Polarity protection: integrated
- Signal transmission: PFM;
current pulses superimposed on base
current from Nivotester
- Function indication: green LED flashes
during self-checking procedure

Accessories for Liquiphant S

- Transparent cover for plastic housing:
Order No. 919229-0001
- Other accessories on request.

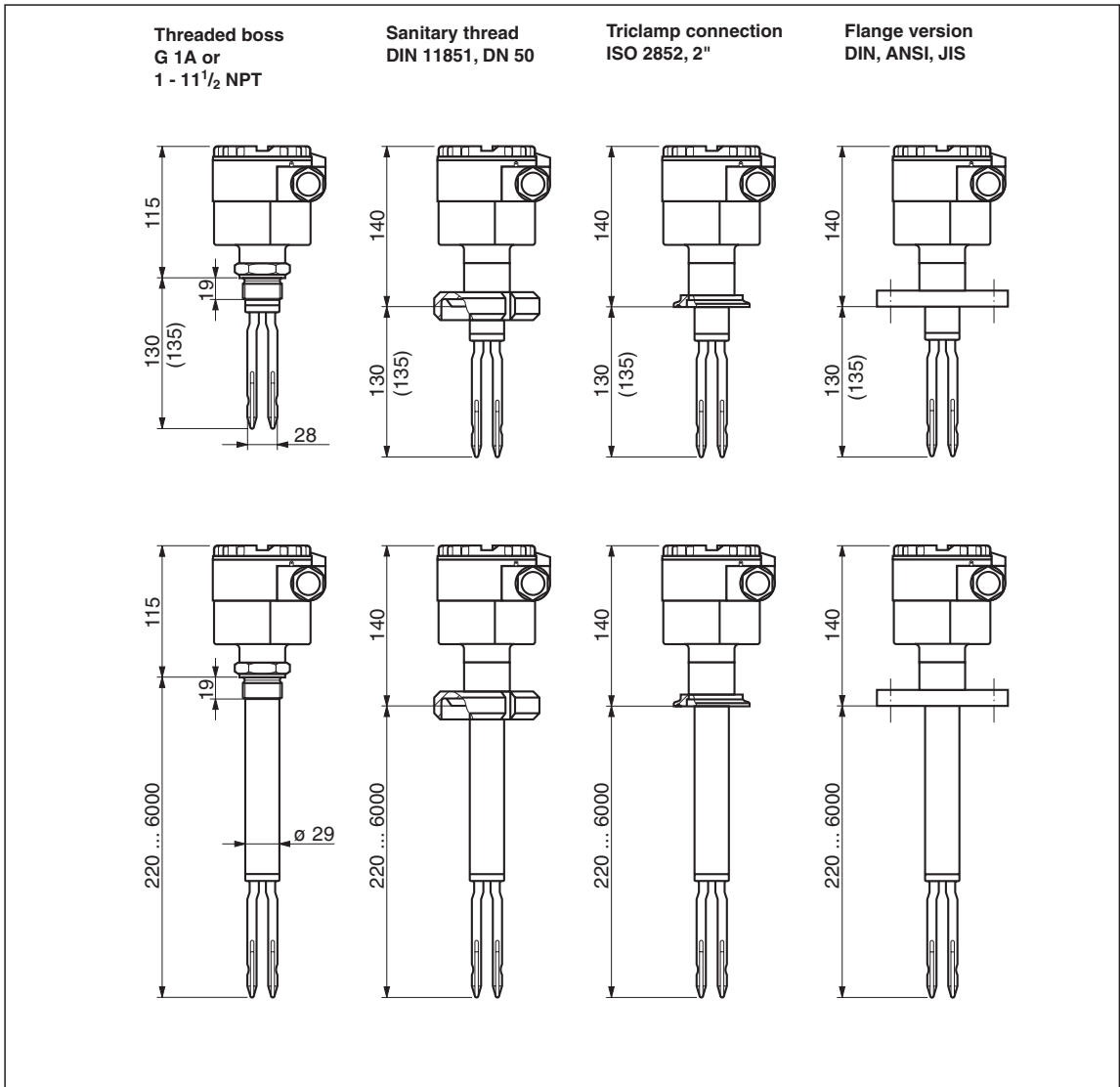

Dimensions in mm
of the Liquiphant S
sensor;
top row: FDL 60
bottom row: FDL 61

(dimensions in brackets
for version with
Hastelloy fork)

Production tolerances:
of length
length tolerances
up to 1 m +0 mm, -7 mm
up to 3 m +0 mm, -10 mm
up to 6 m +0 mm, -20 mm

NPT thread:
length tolerances
up to 1 m +2 mm, -7 mm
up to 3 m +2 mm, -10 mm
up to 6 m +2 mm, -20 mm

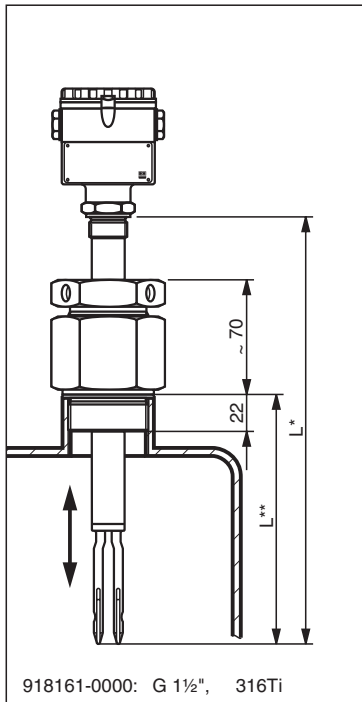

FDL 61 with sliding sleeve

L* min. 320 mm
L** min. 220 mm

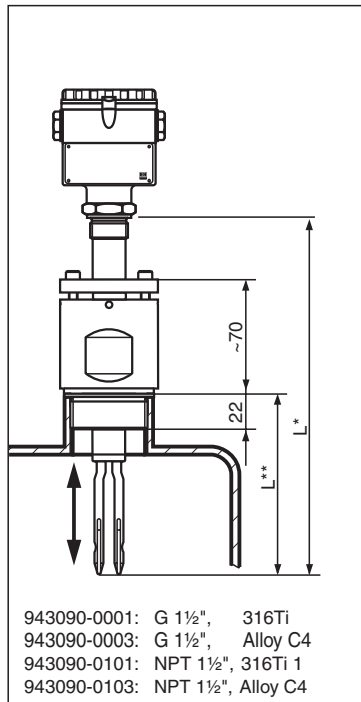

FDL 61 with high pressure sliding sleeve

L* min. 320 mm
L** min. 220 mm

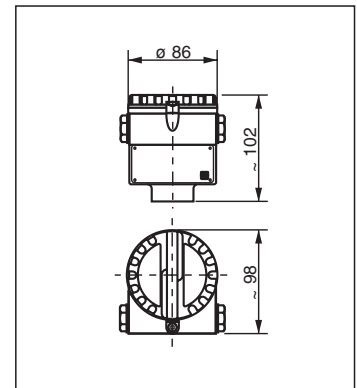

Housing dimensions

100 mm = 3.94 in
1 in = 25.4 mm

FDL 60 Compact version
FDL 61 Version with extension tube
Weight

Certificate

- B ATEX II 1/2 G, EEx ia IIC T6, Liquefied gas application to VdTÜV 100 (Germany)
- F ATEX II 1/2 G, EEx ia IIC T6, Overspill protection to WHG (Germany)
- G ATEX II 1/2 G, EEx ia IIC T6
- R For non-hazardous areas
- Y Special version

Process Connection and Material

Basic weight**

GN2	Gewinde ANSI 1" NPT, 316 Ti	1,1 kg
GN5	Gewinde ANSI 1" NPT, Alloy C	1,1 kg
GR2	Gewinde G 1 A, 316 Ti	1,1 kg
GR5	Gewinde G 1 A, Alloy C	1,1 kg
ME2	DN 50, PN 40, 316 Ti, DIN 11851, Hygienic connection	1,6 kg
SN2	Thread ANSI 1 1/2" NPT, 316 Ti, sliding sleeve for FDL 61	2,4 kg
SN5	Thread ANSI 1 1/2" NPT, Alloy C, sliding sleeve for FDL 61	2,4 kg
SR2	Thread G 1 1/2 A, 316 Ti, sliding sleeve for FDL 61	2,4 kg
SR5	Thread G 1 1/2 A, Alloy C, sliding sleeve for FDL 61	2,4 kg
TE2	DN 40-51, 2", 316 Ti, ISO 2852, Tri-Clamp connection	1,2 kg

Additional weight

AA2	1 1/4", 150 lbs, RF, 316 Ti, ANSI B 16.5	1,2 kg
AC2	1 1/2", 150 lbs, RF, 316 Ti, ANSI B 16.5	1,5 kg
AE2	2", 150 lbs, RF, 316 Ti, ANSI B 16.5	2,4 kg
AE5	2", 150 lbs, RF, 316 Ti, ANSI B 16.5, Alloy C	2,4 kg
AG2	2", 300 lbs, RF, 316 Ti, ANSI B 16.5	3,2 kg
AG5	2", 300 lbs, RF, 316 Ti, ANSI B 16.5, Alloy C	3,2 kg
AK2	2 1/2", 300 lbs, RF, 316 Ti, ANSI B 16.5	4,9 kg
AL2	3", 150 lbs, RF, 316 Ti, ANSI B 16.5	4,9 kg
AN2	3", 300 lbs, RF, 316 Ti, ANSI B 16.5	6,8 kg
AP2	4", 150 lbs, RF, 316 Ti, ANSI B 16.5	7,0 kg
AR2	4", 300 lbs, RF, 316 Ti, ANSI B 16.5	11,5 kg
AV2	6", 150 lbs, RF, 316 Ti, ANSI B 16.5	11,3 kg
A12	6", 300 lbs, RF, 316 Ti, ANSI B 16.5	20,9 kg
BA2	DN 32, PN 6, B, 316 Ti, DIN 2527	1,2 kg
BB2	DN 32, PN 25/40, B, 316 Ti, DIN 2527	1,4 kg
BC2	DN 40, PN 6, B, 316 Ti, DIN 2527	1,4 kg
BD2	DN 40, PN 25/40, B, 316 Ti, DIN 2527	2,4 kg
BE2	DN 50, PN 6, B, 316 Ti, DIN 2527	1,6 kg
BG2	DN 50, PN 25/40, B, 316 Ti, DIN 2527	3,2 kg
BK2	DN 65, PN 25/40, B, 316 Ti, DIN 2527	4,3 kg
BM2	DN 80, PN 10/16, B, 316 Ti, DIN 2527	4,8 kg
BN2	DN 80, PN 25/40, B, 316 Ti, DIN 2527	5,9 kg
BQ2	DN 100, PN 10/16, B, 316 Ti, DIN 2527	5,6 kg
BR2	DN 100, PN 25/40, B, 316 Ti, DIN 2527	7,5 kg
CA5	DN 32, PN 6, 316 L, DIN 2527, Alloy C	1,2 kg
CE5	DN 50, PN 6, 316 L, DIN 2527, Alloy C	1,6 kg
CG2	DN 50, PN 25/40, C, 316 Ti, DIN 2527	3,2 kg
CG5	DN 50, PN 25/40, 316 Ti, DIN 2527, Alloy C	3,2 kg
CN2	DN 80, PN 25/40, C, 316 Ti, DIN 2527	5,9 kg
CN5	DN 80, PN 25/40, 316 L, DIN 2527, Alloy C	5,9 kg
CQ2	DN 100, PN 10/16, C, 316 Ti, DIN 2527	5,6 kg
CQ5	DN 100, PN 10/16, 316 Ti, DIN 2527, Alloy C	5,6 kg
CR2	DN 100, PN 25/40, C, 316 Ti, DIN 2527	7,5 kg
FG2	DN 50, PN 40, tongue, 316 Ti, DIN 2512	3,2 kg
FN2	DN 80, PN 40, tongue, 316 Ti, DIN 2512	5,9 kg
FR2	DN 100, PN 40, tongue, 316 Ti, DIN 2512	7,5 kg
KE2	JIS B2210, 10K 50A, RF, 316 Ti	
KE5	JIS B2210, 10K 50A, RF, 316 Ti, Alloy C	
NG2	DN 50, PN 40, groove, 316 Ti, DIN 2512	3,2 kg
NN2	DN 80, PN 40, groove, 316 Ti, DIN 2512	5,9 kg
NR2	DN 100, PN 40, groove, 316 Ti, DIN 2512	7,5 kg
YY9	Special version	

** The basic weight consists of
 Process connection, plastic housing, electronic insert, packaging

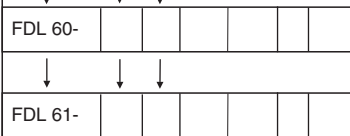

Product structure
 for Liquiphant S
 FDL 60, FDL 61

Fork Surface Finis

- A Standard finish, Ra < 3,2 µm / 80 grid
- B Polished version, Ra < 1,5 µm / 120 grid
- Y Special version

Additional weight

Extension Tube Material for FDL 61

- Amm length (220...6000 mm), SS316Ti 1,4 kg/m
- Cmm length (220...6000 mm), Alloy C 1,5 kg/m
- Gmm length (220...6000 mm), SS316Ti, polished 1,4 kg/m
- Y Special version
- 1inch length (8,7...236,2 in), SS316Ti 1,4 kg/m
- 3inch length (8,7...236,2 in), Alloy C 1,5 kg/m
- 4inch length (8,7...236,2 in), SS316Ti, polished 1,4 kg/m

Electronic Insert

- 7 FEL 67, 2-wire, PFM transmission
- 9 Special version

Housing, Cable Gland

- L Housing F10: polyester, IP66, 1/2" NPT
- M Housing F10: polyester, IP66, G 1/2"
- O Housing F10: polyester, IP66, M 20x1,5
- P Housing F10: polyester, IP66, HNA 24 gland
- T Housing F6: aluminium, IP66, 1/2" NPT 0,2 kg
- U Housing F6: aluminium, IP66, G 1/2" 0,2 kg
- V Housing F6: aluminium, IP66, M 20x1,5 0,2 kg
- W Housing F6: aluminium, IP66, HNA 24 gland 0,2 kg
- Y Special version

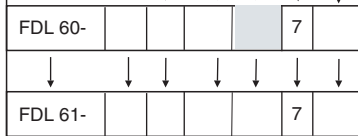

Product designation

Total weight

Product designation

Total weight

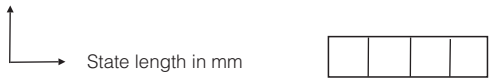

Production tolerances of length see Page 8

Technical Data for Nivotester FTL 670

Construction

- Racksyst plug-in card to: DIN 41 494, d = 160 mm, h = 100 mm (Eurocard)
- Front panel: black plastic with embossed blue field, handle and tag field
- Width: 4 HP (20.3 mm)
- Height: 3 Hu (128.4 mm)
- Plug connection: multipoint connector to DIN 41 612, Part 3, Type F, (reduced) 25-pole assembly for "Monorack II" ("Racksyst II")
- Coding holes in the multipoint connector: Pos. 2 and 11
- Protection to DIN 40 050: Front panel IP20, plug-in board IP00
- Weight: 200 g

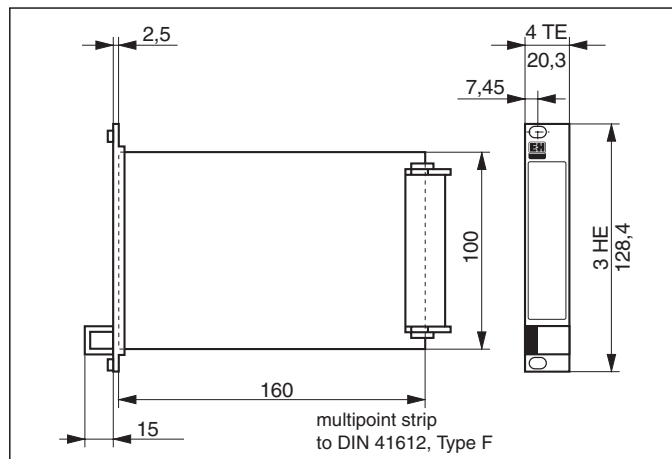

Dimensions in mm
of Racksyst plug-in board
Nivotester FTL 670

Operating Data

- Permissible ambient temperatures:
 - Nominal operating range: -25 °C ... +70 °C (-10°F...+160°F)
 - Storage: -40 °C ... +85 °C
- Climatic class to DIN 40 040: HSE

Power Supply

- DC voltage: 24 V (20 ... 30 V)
- Permissible residual ripple within tolerance: $U_{pp} \leq 2$ V
- Current consumption: max. 105 mA
- Power consumption at 24 V: max. 2.5 W
- Power consumption at 30 V: max. 3.2 W
- Fine-wire fuse and polarity protection: integrated

Signal Input

- Input FTL 670: electrically isolated from other circuits
- Sensors: Liquiphant S FDL 60, FDL 61 with electronic insert FEL 67
- Power supply for sensor: from the Nivotester
 - voltage: 10.5 ... 12.5 V
 - base current: approx. 7 ... 11 mA
- Connection cable: two-wire, screening not required
- Cable resistance: max. 25 Ω per wire
- Signal transmission: Pulse Frequency Modulation
 - frequency range: 120 ... 450 Hz
 - pulse current: approx. 16 ... 23 mA, superimposed on base current
- Ignition protection: intrinsic safety [EEx ia] IIC ATEX II (1) G, [EEx ia] IIC
Further information: see certificates and Notes on Safety XA

Output

- Instrument alarm: one relay with potential-free changeover contact
- Level alarm: three relays each with one potential-free changeover contact connected in series (fail-safe contact)
- Fail-safe circuit for level alarm: maximum fail-safe
- Switching delay (entire measuring system):
 - with fork covered approx. 0.5 s
 - with fork uncovered approx. 1 s
 - on occurrence of fault max. 3 s safety time
- Switching capacity of relay contacts:
 - with AC current max. 230 V, max. 2.5 A, max. 600 VA at $\cos \varphi = 1$, max. 300 VA at $\cos \varphi \geq 0.7$
 - with DC current max. 120 V, max. 2.5 A, max. 75 W
- When connecting a low-voltage circuit with double isolation according to IEC 1010 the following applies: Total of voltages of relay output and power supply max. 300 V
- Function and alarm indicators on front panel: 7 LEDs

Accessories for Nivotester FTL 670

Plug-in point kit 25/2, consisting of multipoint connector, coding pins, isolating cap, guide rails

Connection:	Order No.:
Wire-wrap 1 x 1	918365-2500
Solder connection	918365-2530
Maxi-Termipoint 2.4 x 0.8	918365-2520
Mini-Termipoint 1.6 x 0.8	918365-2510

Order Specifications

Liquiphant S FDL 60, FDL 61

- Product designation based on structure, page 9/10
- Length for FDL 61 in mm
- Accessories

Nivotester FTL 670

- Order No. 016501-0040
- Accessories

Supplementary Documentation

Accessories

Monorack II

Technical Information TI 183F/00/en

Monorack Protective Housing

Technical Information TI 099F/00/en

19" Assembly Rack

System-Information Racksyst

SI 008F/00/en

Project Information SD 041F/00/en

Racksyst Field Housing

Technical Information PI 026

Project Information PI 003

Overvoltage Protector HAW 262

Technical Information TI 108F/00/en

Overvoltage Protector HAW 262 Z

For explosion hazardous areas

Technical Information TI 092F/00/de

Other accessories on request

Certificates

Notes on Safety to ATEX
(KEMA 97 ATEX 4490)
for Liquiphant S FDL 60, FDL 61
Operating Instructions XA027F/00/a3

Notes on Safety to ATEX
(PTB 00 ATEX 2008)
for Nivotester FTL 670
Operating Instructions XA069F/00/a3

Special German Certificates on request

Endress+Hauser
GmbH+Co. KG
Instruments
International
P.O. Box 2222
D-79574 Weil am Rhein
Germany

Tel. (07621) 975-02
Fax (07621) 975-345
<http://www.endress.com>
info@ii.endress.com

Endress + Hauser
The Power of Know How

