



Level



Pressure



Flow



Temperature

Liquid
Analysis

Registration

Systems
Components

Services



Solutions

Technical Information

Levelflex FMP51, FMP52, FMP54

Guided Level-Radar

Level and interface measurement in liquids



Application

- FMP51 – premium device for level and interface measurement in liquids.
- FMP52 – premium device with coated probe for the use in aggressive liquids. Material of wetted parts FDA listed and USP Class VI compliant.
- FMP54 – premium device for high-temperature and high-pressure applications, mainly in liquids.
- Measuring range up to 45 m (148 ft)
- Process connection starting 3/4" thread or flange
- Temperature range:
 - 196 to +450 °C (–321 to +842 °F)
- Pressure range: –1 to 400 bar (–14.5 to 5800 psi)
- The following interfaces are available for system integration:
 - HART with 4...20 mA analog
 - PROFIBUS PA (Profile 3.02)
 - FOUNDATION Fieldbus
- Used for level monitoring (MIN, MAX, range) up to SIL 2 (single device) or SIL 3 (redundancy, even if homogeneous), independently assessed by TÜV as per IEC 61508

Your benefits

- Reliable measuring:
 - in case of moved surface and foam
 - for changing media
 - in dust applications (FMP54 only)
- High availability
- Integrated data memory
- Factory precalibrated to probe length
- Intuitive, menu-guided operating concept in national languages
- Simple integration into control or asset management systems
- Exact instrument and process diagnosis to assist fast decisions
- Approvals: ATEX, IEC Ex, CSA, FM, NEPSI Pressure Equipment Directive PED (FMP54 only) 3-A (FMP52 only)

Table of contents

Important document information	4	Ambient temperature limits	49
Document conventions	4	Storage temperature	56
Function and system design	6	Climate class	56
Measuring principle	6	Geometric height	56
Measuring system	9	Degree of protection	56
Input	12	Vibration resistance	56
Measured variable	12	Cleaning the probe	56
Measuring range	12	Electromagnetic compatibility (EMC)	56
Blocking distance	13	Operating conditions: Process	56
Measuring frequency spectrum	13	Process temperature range	56
Output	13	Process pressure limits	57
Output signal	13	Materials in contact with process	58
Signal on alarm	14	Dielectric constant (DC)	60
Linearization	14	Extension of the rope probes through temperature	60
Galvanic isolation	14	Mechanical construction	61
Protocol-specific data	14	Design, dimensions	61
Auxiliary energy	19	Surface roughness of AlloyC-coated flanges	68
Electrical connection	19	Tolerance of probe length	68
Supply voltage	25	Weight	68
Terminals	26	Materials	69
Cable entries	26	Operability	71
Cable specification	26	Operating concept	71
Device plug connectors	27	Local operation	72
Power consumption	27	Remote operation	72
Current consumption	27	Integration in tank gauging system	76
Power supply failure	28	System integration via Fieldgate	77
Maximum load	28	Certificates and approvals	78
Potential equalization	29	CE mark	78
Overvoltage protection	29	C-Tick symbol	78
Performance characteristics	29	Ex approval	78
Reference operating conditions	29	Functional Safety	78
Maximum measured error	29	Sanitary compatibility	78
Resolution	30	AD2000	78
Reaction time	31	Pressure Equipment Directive	78
Influence of ambient temperature	31	Steam boiler approval	78
Influence of gas layer	31	Telecommunications	78
Gas phase compensation with external pressure sensor (PROFIBUS PA)	32	CRN approval	78
Gas phase compensation with reference signal (option for FMP54)	32	Track record	78
Operating conditions: Installation	34	Other standards and guidelines	78
Suitable mounting position	34	Ordering information	79
Applications with restricted mounting space	35	Compact device Levelflex	79
Notes on the mechanical load of the probe	36	Product structure FMP51, FMP52, FMP54	79
Notes on the process connection	37	Accessories	89
Securing the probe	40	Device-specific accessories	89
Special mounting conditions	42	Communication-specific accessories	94
Operating conditions: Environment	49	Service-specific accessories	95
Ambient temperature range	49	System components	95
		Documentation	96
		Standard documentation	96

Supplementary documentation 96
Certificates 96





Registered trademarks 97

Patents 98





Important document information

Document conventions







Safety symbols

Symbol	Meaning
 A0011189-EN	DANGER! This symbol alerts you to a dangerous situation. Failure to avoid this situation will result in serious or fatal injury.
 A0011190-EN	WARNING! This symbol alerts you to a dangerous situation. Failure to avoid this situation can result in serious or fatal injury.
 A0011191-EN	CAUTION! This symbol alerts you to a dangerous situation. Failure to avoid this situation can result in minor or medium injury.
 A0011192-EN	NOTICE! This symbol contains information on procedures and other facts which do not result in personal injury.



Electrical symbols

Symbol	Meaning
 A0011197	Direct current A terminal to which DC voltage is applied or through which direct current flows.
 A0011198	Alternating current A terminal to which alternating voltage (sine-wave) is applied or through which alternating current flows.
 A0011200	Ground connection A grounded terminal which, as far as the operator is concerned, is grounded via a grounding system.
 A0011199	Protective ground connection A terminal which must be connected to ground prior to establishing any other connections.
 A0011201	Equipotential connection A connection that has to be connected to the plant grounding system: This may be a potential equalization line or a star grounding system depending on national or company codes of practice.

Symbols for certain types of information

Symbol	Meaning
 A0011182	Allowed Indicates procedures, processes or actions that are allowed.
 A0011183	Preferred Indicates procedures, processes or actions that are preferred.
 A0011184	Forbidden Indicates procedures, processes or actions that are forbidden.
 A0011193	Tip Indicates additional information.
 A0011194	Reference to documentation Refers to the corresponding device documentation.
 A0011195	Reference to page Refers to the corresponding page number.
 A0011196	Reference to graphic Refers to the corresponding graphic number and page number.

Symbols in graphics

Symbol	Meaning
1, 2, 3 ...	Item numbers
1., 2., 3. ...	Series of steps
A, B, C, ...	Views
A-A, B-B, C-C, ...	Sections
 <small>A0011187</small>	Hazardous area Indicates a hazardous area.
 <small>A0011188</small>	Safe area (non-hazardous area) Indicates a non-hazardous location.

Function and system design

Measuring principle

Level measurement

The Levelflex is a "downward-looking" measuring system that functions according to the ToF method (ToF = Time of Flight). The distance from the reference point to the product surface is measured. High-frequency pulses are injected to a probe and led along the probe. The pulses are reflected by the product surface, received by the electronic evaluation unit and converted into level information. This method is also known as TDR (Time Domain Reflectometry).

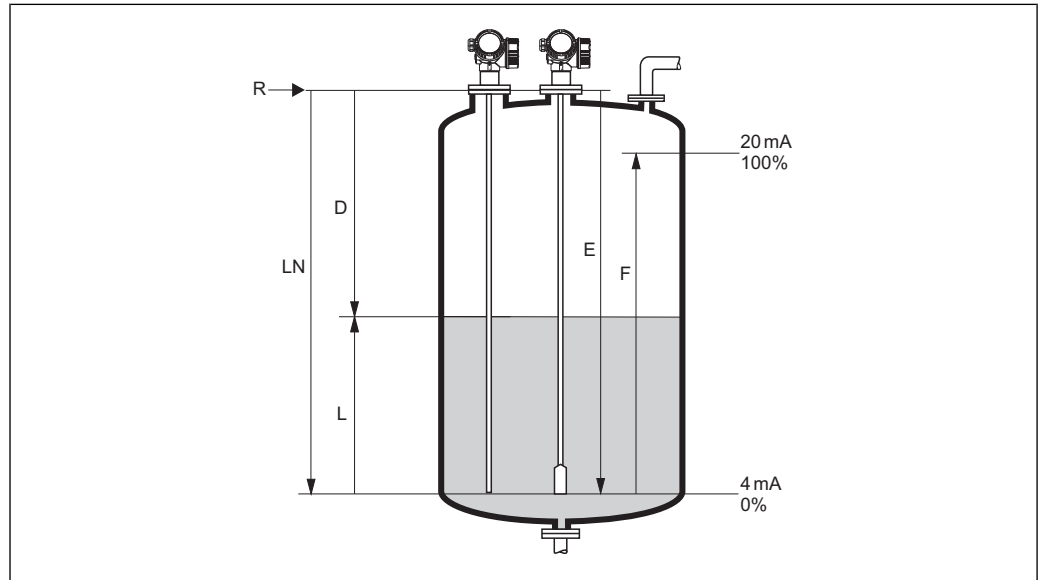

LN = probe length

D = distance

L = level

R = reference point of measurement

E = empty calibration (= zero)

F = full calibration (= span)



If, for rope probes, the DC value is less than 7, then measurement is not possible in the area of the straining weight (0 to 250 mm from end of probe; lower blocking distance).

Dielectric constant

The dielectric constant (DC) of the medium has a direct impact on the degree of reflection of the high-frequency pulses. In the case of large DC values, such as for water or ammonia, there is strong pulse reflection while, with low DC values, such as for hydrocarbons, weak pulse reflection is experienced.

Input

The reflected pulses are transmitted from the probe to the electronics. There, a microprocessor analyzes the signals and identifies the level echo which was generated by the reflection of the high-frequency pulses at the product surface. This clear signal detection system benefits from over 30 years' experience with pulse time-of-flight procedures that have been integrated into the development of the PulseMaster® software.

The distance D to the product surface is proportional to the time of flight t of the impulse:

$$D = c \cdot t/2,$$

where c is the speed of light.

Based on the known empty distance E , the level L is calculated:

$$L = E - D$$

The reference point R of the measurement is located at the process connection. For details see the dimensional drawing:

- FMP51: (→ 63)(→ 64)
- FMP52: (→ 66)
- FMP54: (→ 67)

The Levelflex possesses functions for interference echo suppression that can be activated by the user. They guarantee that interference echoes from e.g. internals and struts are not interpreted as level echoes.

Output

The Levelflex is preset at the factory to the probe length ordered so that in most cases only the application parameters that automatically adapt the device to the measuring conditions need to be entered. For models with a current output, the factory adjustment for zero point E and span F is 4 mA and 20 mA, for digital outputs and the display module 0 % and 100 %. A linearization function with max. 32 points, which is based on a table entered manually or semi-automatically, can be activated on site or via remote operation. This function allows the level to be converted into units of volume or mass, for example.

Interface measurement

When the high-frequency pulses hit the surface of the medium, only a percentage of the transmission pulse is reflected. In the case of media with a low DC₁, in particular, the other part penetrates the medium. The pulse is reflected once more at the interface point to a second medium with a higher DC₂. The distance to the interface layer now can also be determined taking into account the delayed time-of-flight of the pulse through the upper medium.

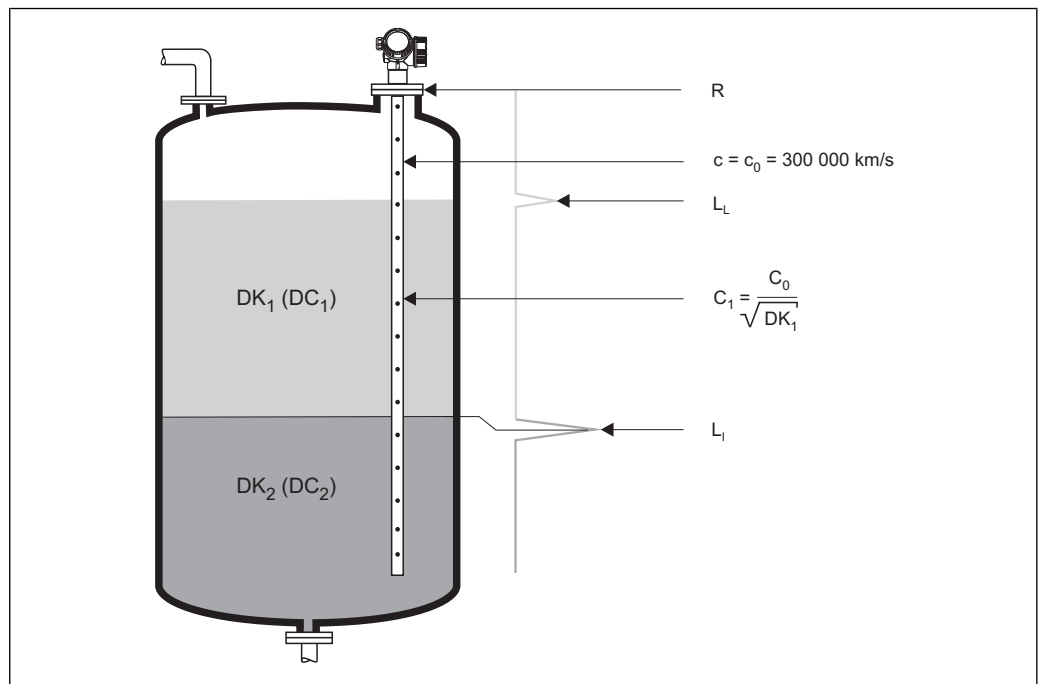

A001178

- L_L* = level complete
- L_I* = level interface
- R* = reference point of measurement

In addition, the following general conditions must be observed for interface measurement:

- The DC of the upper medium must be known and constant. The DC can be determined with the aid of the DC manual SD106F. In addition, whenever the interface thickness is existing and known, the DC can be calculated automatically via FieldCare.
- The DC of the upper medium may not be greater than 10.
- The DC difference between the upper medium and lower medium must be >10.
- The upper medium must have a minimum thickness of 80 mm.
- Conductivity of the upper medium: < 1 μS/cm
- Conductivity of the lower medium: > 100 μS/cm

Life cycle of the product

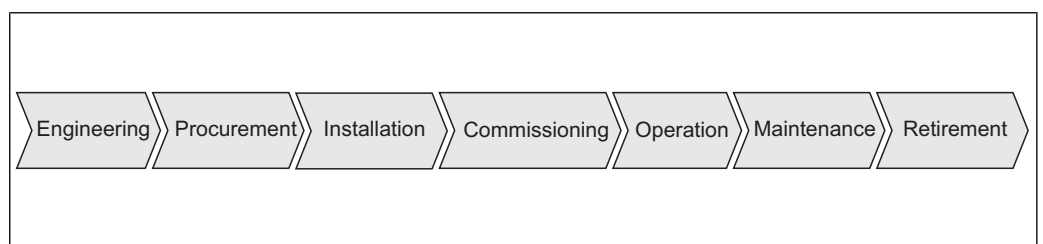

A0013773-EN

Engineering

- Universal measuring principle
- Measurement unaffected by medium properties
- Hardware and software developed according to SIL IEC 61508
- Genuine, direct interface measurement

Procurement

- Endress+Hauser being the world market leader in level measurement guarantees asset protection
- Worldwide support and service

Installation

- Special tools are not required
- Reverse polarity protection
- Modern, detachable terminals
- Main electronics protected by a separate connection compartment

Commissioning

- Fast, menu-guided commissioning in only 6 steps
- Plain text display in national languages reduces the risk of error or confusion
- Direct local access of all parameters
- Short instruction manual at the device

Operation

- Multi-echo tracking: Reliable measurement through self-learning echo-search algorithms taking into account the short-term and long-term history in order to check the found echoes for plausibility and to suppress interference echoes.
- Diagnostics in accordance with NAMUR NE107

Maintenance

- HistoROM: Data backup for instrument settings and measured values
- Exact instrument and process diagnosis to assist fast decisions with clear details concerning remedies
- Intuitive, menu-guided operating concept in national languages saves costs for training, maintenance and operation
- Cover of the electronics compartment can be opened in hazardous areas

Retirement

- Order code translation for subsequent models
- RoHS-conforming (Restriction of certain Hazardous Substances), unleaded soldering of electronic components
- Environmentally sound recycling concept



Measuring system

General notes on probe selection



- Normally use rod or coax probes for liquids. Rope probes are used in liquids for measuring ranges > 10 m (33 ft) (> 4 m (13 ft) for FMP52) and with restricted ceiling clearance which does not allow the installation of rigid probes.
- For interface measurement, ideally coax probes or rod probes in a bypass/stilling well are used.
- Coax probes are suited to liquids with viscosities of up to approx. 500 cst. Coax probes can measure most liquefied gases, as of a dielectric constant of 1.4. Moreover, installation conditions, such as nozzles, tank internal fittings etc., have no effect on the measurement when a coax probe is used. A coax probe offers maximum EMC safety when used in plastic tanks.

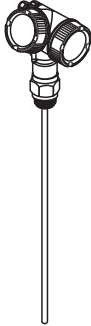

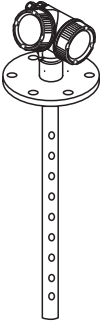
Probe selection

The various types of probe in combination with the process connections are suitable for the following applications:

Levelflex FMP51						
Type of probe	Rod probe		Rope probe		Coax probe ¹⁾	
	 A0011387		 A0011388		 A0011359	
Feature 060 - Probe:	Option:		Option:		Option:	
	AA	8 mm (316L)	LA	4 mm (316)	UA	... mm (316L)
	AB	1/3" (316L)	LB	1/6" (316)	UB	... inch (316L)
	AC	12 mm (316L)	MB	4 mm (316) with center rod	UC	... mm (AlloyC)
	AD	1/2" (316L)	MD	1/6" (316) with center rod	UD	... inch (AlloyC)
	AL	12 mm (AlloyC)				
	AM	1/2" (AlloyC)				
	BA BC	16 mm (316L) divisible				
BB BD	0.63 in (316L) divisible					
Max. probe length	10 m (33 ft)		45 m (148 ft)		6 m (20 ft)	
For application	level and interface measurement in liquids		level and interface measurement in liquids		level and interface measurement in liquids	

1) Multiple punched for process connections G1-1/2" or flange

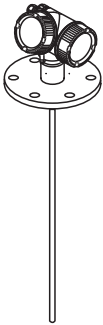
Levelflex FMP52				
Type of probe	Rod probe		Rope probe	
	 A0011357		 A0011358	
Feature 060 - Probe:	Option:		Option:	
	CA	16 mm (PFA>316L)	OA	4 mm (PFA>316), max. 150 mm nozzle height, center rod
	CB	0.63 in (PFA>316L)	OB	4 mm (PFA>316), max. 300 mm nozzle height, center rod
			OC	1/6" (PFA>316), max. 6 in nozzle height, center rod
			OD	1/6" (PFA>316), max. 12 in nozzle height, center rod
Max. probe length	4 m (13 ft)		45 m (148 ft)	
For application	level and interface measurement in corrosive liquids		level and interface measurement in corrosive liquids	

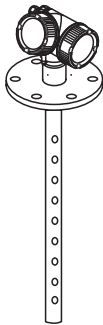
Levelflex FMP54						
Type of probe	Rod probe		Rope probe	Coax probe		
	 A0011357		 A0011358	 A0011359		
Feature 060 - Probe:	Option:		Option:			
	AE BA BC	16 mm (316L)	LA	4 mm (316)	UA	... mm (316L)
	AF BB BD	0.63 in (318L)	LB	1/6" (316)	UB	... inch (316L)
Max. probe length	10 m (33 ft)		45 m (148 ft)	6 m (20 ft)		
For application	level and interface measurement in liquids		level and interface measurement in liquids	level and interface measurement in liquids		



If required, rod and rope probes can be replaced. They are secured with Nord-Lock washers or a thread coating.

For further information on service and spare parts please contact the Endress+Hauser service.

Input

Measured variable

The measured variable is the distance between the reference point and the product surface.

Subject to the empty distance entered "E" the level is calculated.

Alternatively, the level can be converted into other variables (volume, mass) by means of linearization (32 points).

Measuring range

The following table describes the media groups and the possible measuring range as a function of the media group.

Levelflex FMP51, FMP54					
Media group	DC (ϵ_r)	Typical liquids	Measuring range ¹⁾		
			bare metallic rod probes ²⁾	bare metallic rope probes	coax probes
1	1.4...1.6	condensed gases, e.g. N ₂ , CO ₂	on request		
2	1.6...1.9	<ul style="list-style-type: none"> ■ liquefied gas, e.g. propane ■ solvent ■ Freon ■ palm oil 	4/10 m (13/33 ft)	15 to 22 m (49 to 72 ft)	6 m (20 ft)
3	1.9...2.5	mineral oils, fuels	4/10 m (13/33 ft)	22 to 32 m (72 to 105 ft)	6 m (20 ft)
4	2.5...4	<ul style="list-style-type: none"> ■ benzene, styrene, toluene ■ furan ■ naphthalene 	4/10 m (13/33 ft)	32 to 42 m (105 to 138 ft)	6 m (20 ft)
5	4...7	<ul style="list-style-type: none"> ■ chlorobenzene, chloroform ■ cellulose spray ■ isocyanate, aniline 	4/10 m (13/33 ft)	42 to 45 m (138 to 148 ft)	6 m (20 ft)
6	> 7	<ul style="list-style-type: none"> ■ aqueous solutions ■ alcohols ■ ammonia 	4/10 m (13/33 ft)	45 m (148 ft)	6 m (20 ft)

1) The measuring range for interface measurement is limited to 10 m (33 ft). Larger measuring range available on request.

2) one-piece up to 4 m (13 ft), divisible up to 10 m (33 ft)

Levelflex FMP52				
Media group	DC (ϵ_r)	Typical liquids	Measuring range ¹⁾	
			PFA-coated rod probes	PFA-coated rope probes
1	1.4...1.6	condensed gases, e.g. N ₂ , CO ₂	—	—
2	1.6...1.9	<ul style="list-style-type: none"> ■ liquefied gas, e.g. propane ■ solvent ■ Freon ■ palm oil 	4 m (13 ft)	9 to 14 m (30 to 46 ft)
3	1.9...2.5	mineral oils, fuels	4 m (13 ft)	14 to 21 m (46 to 69 ft)
4	2.5...4	<ul style="list-style-type: none"> ■ benzene, styrene, toluene ■ furan ■ naphthalene 	4 m (13 ft)	21 to 28 m (69 to 92 ft)
5	4...7	<ul style="list-style-type: none"> ■ chlorobenzene, chloroform ■ cellulose spray ■ isocyanate, aniline 	4 m (13 ft)	28 to 32 m (92 to 105 ft)
6	> 7	<ul style="list-style-type: none"> ■ aqueous solutions ■ alcohols ■ acids, alkalis 	4 m (13 ft)	32 to 45 m (105 to 148 ft)

1) The measuring range for interface measurement is limited to 10 m (33 ft). Larger measuring range available on request.

- i ■ Reduction of the max. possible measuring range through buildup, above all of moist products.
- Due to the high diffusion rate of ammonia it is recommended with gas-tight bushing¹⁾ for measurements in this medium.

Blocking distance

The upper blocking distance (= UB) is the minimum distance from the reference point of the measurement (mounting flange) to the maximum level.

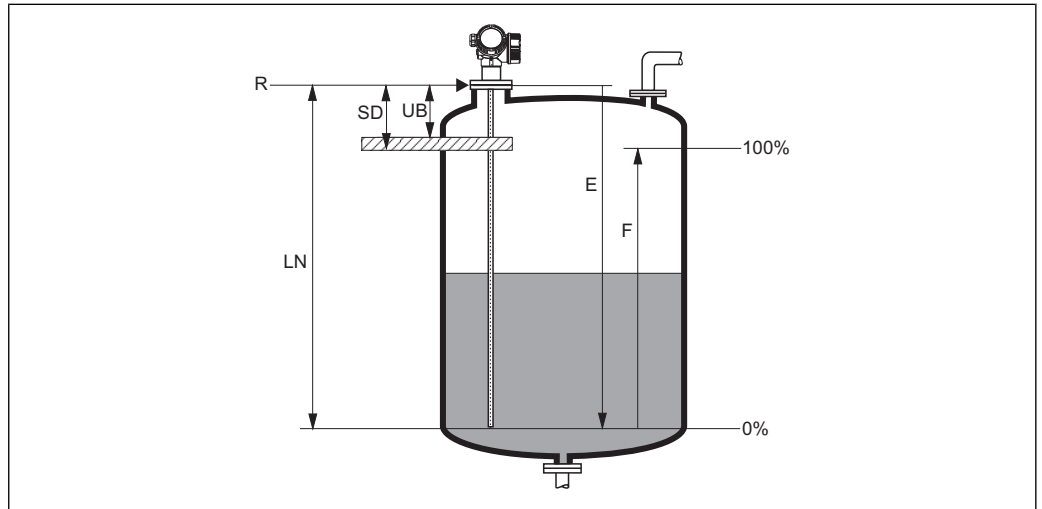

- R = reference point of measurement*
- LN = probe length*
- UB = upper blocking distance*
- E = empty calibration (= zero)*
- F = full calibration (= span)*
- SD = safety distance*

Blocking distance (factory setting):

- with coax probes: 0 mm (0 in)
- with rod and rope probes up to 8 m (26 ft): 200 mm (8 in)
- with rod and rope probes exceeding a length of 8 m (26 ft): 0.025 * (length of probe)

i The specified blocking distances are preset on delivery. Depending on the application these settings can be changed.

For rod and rope probes and for media with DC > 7 (or generally for stilling well/bypass applications) the blocking distance may be reduced to 100 mm (4").

Within the blocking distance, a reliable measurement can not be guaranteed.

i A safety distance SD can be defined in addition to the blocking distance. A warning is generated if the level rises into this safety distance.

Measuring frequency spectrum

100 MHz to 1.5 GHz

Output

Output signal

HART

Signal coding	FSK ±0.5 mA over currenxy signal
Data transmission rate	1200 Baud
Galvanic isolation	Yes

1) for FMP54 always contain, for FMP51/52 optionally available

PROFIBUS PA

Signal coding	Manchester Bus Powered (MBP)
Data transmission rate	31,25 KBit/s, voltage mode
Galvanic isolation	Yes

FOUNDATION Fieldbus

Signal coding	Manchester Bus Powered (MBP)
Data transmission rate	31,25 KBit/s, voltage mode
Galvanic isolation	Yes

Signal on alarm

Depending on the interface, failure information is displayed as follows:

- Current output (for HART devices)
 - Failsafe mode selectable (in accordance with NAMUR Recommendation NE 43):
 - Minimum alarm: 3.6 mA
 - Maximum alarm (= factory setting): 22 mA
 - Failsafe mode with user-selectable value: 3.59 to 22.5 mA
- Local display
 - Status signal (in accordance with NAMUR Recommendation NE 107)
 - Plain text display
- Operating tool via digital communication (HART, PROFIBUS PA, FOUNDATION Fieldbus) or service interface (CDI)
 - Status signal (in accordance with NAMUR Recommendation NE 107)
 - Plain text display

Linearization

The linearization function of the device allows the conversion of the measured value into any unit of length or volume. Linearization tables for calculating the volume in cylindrical tanks are pre-programmed. Other tables of up to 32 value pairs can be entered manually or semi-automatically.

Galvanic isolation

All circuits for the outputs are galvanically isolated from each other.

Protocol-specific data

HART

Manufacturer ID	17 (0x11)
Device type ID	0x34
HART specification	6.0
Device description files (DTM, DD)	Information and files under: <ul style="list-style-type: none"> ■ www.endress.com ■ www.hartcomm.org
HART load	Min. 250 Ω

HART device variables	<p>The measured values can be freely assigned to the device variables.</p> <p>Measured values for PV (primary variable)</p> <ul style="list-style-type: none"> ■ Level linearized ■ Distance ■ Interface ¹⁾ ■ Interface distance ¹⁾ ■ Upper interface thickness ¹⁾ ■ Electronic temperature ■ Relative echo amplitude ■ Relative interface amplitude ¹⁾ <p>Measured values for SV, TV, FV (second, third and fourth variable)</p> <ul style="list-style-type: none"> ■ Level linearized ■ Distance ■ Interface linearized ¹⁾ ■ Interface distance ¹⁾ ■ Upper interface thickness ¹⁾ ■ Terminal voltage ■ Electronic temperature ■ Absolute echo amplitude ■ Relative echo amplitude ■ Absolute interface amplitude ¹⁾ ■ Relative interface amplitude ¹⁾ ■ Calculated DC
Supported functions	<ul style="list-style-type: none"> ■ Burst mode ■ Additional transmitter status

1) only if an interface measurement is active

PROFIBUS PA

Manufacturer ID	17 (0x11)
Ident number	0x1558
Profile version	3.02
GSD file	Information and files under:
GSD file version	<ul style="list-style-type: none"> ■ www.endress.com ■ www.profibus.org
Output values	<p>Analog Input:</p> <ul style="list-style-type: none"> ■ Level linearized ■ Distance ■ Interface ¹⁾ ■ Interface distance ¹⁾ ■ Upper interface thickness ¹⁾ ■ Terminal voltage ■ Electronic temperature ■ Absolute echo amplitude ■ Relative echo amplitude ■ Absolute interface amplitude ¹⁾ ■ Relative interface amplitude ¹⁾ ■ Calculated DC <p>Digital Input:</p> <ul style="list-style-type: none"> ■ Extended diagnostic blocks ²⁾ ■ Status output PFS Block

Input values	<p>Analog Output:</p> <ul style="list-style-type: none"> ■ Analog value from PLC (for sensor block external pressure and temperature) ■ Analog value from PLC to be indicated on the display <p>Digital Output:</p> <ul style="list-style-type: none"> ■ Extended diagnostic block ²⁾ ■ Level limiter ■ Sensor block measurement on ■ Sensor block save history on ■ Status output
Supported functions	<ul style="list-style-type: none"> ■ Identification & Maintenance Simple device identification via control system and nameplate ■ Automatic Ident Number Adoption GSD compatibility mode with respect to the previous device Levelflex M FMP4x ■ Physical Layer Diagnostics Installation check of the PROFIBUS segment and the Levelflex FMP4x via terminal voltage and telegram monitoring ■ PROFIBUS Up-/Download Up to 10 times faster reading and writing of parameters via PROFIBUS Up-/Download ■ Condensed Status Simple and self-explanatory diagnostic information due to categorization of diagnostic messages

- 1) only if an interface measurement is active
 2) in preparation

FOUNDATION Fieldbus

Manufacturer ID	452B48 hex
Device type	1022 hex
Device Revision	02 hex
DD Revision	Information and files can be found:
CFF Revision	<ul style="list-style-type: none"> ■ www.endress.com ■ www.fieldbus.org
Device Tester Version (ITK Version)	6.01
ITK Test Campaign Number	IT080500
Link Master (LAS) capable	yes
Link Master / Basic Device selectable	yes; default: Basic Device
Node address	Default: 247 (0xF7)
Features supported	<p>Following methods are supported:</p> <ul style="list-style-type: none"> ■ Restart ■ ENP Restart ■ Setup ■ Linearization ■ Self Check
Virtual Communication Relationships (VCRs)	
Number of VCRs	44
Number of Link Objects in VFD	50
Permanent entries	1
Client VCRs	0
Server VCRs	10
Source VCRs	43
Sink VCRs	0
Subscriber VCRs	43

Publisher VCRs	43
Device Link Capabilities	
Slot time	4
Min. inter PDU delay	8
Max. response delay	20

Transducer Blocks

Block	Content	Output values
Setup Transducer Block	Contains all parameters for a standard commissioning procedure	<ul style="list-style-type: none"> ■ Level or volume ¹⁾ (Channel 1) ■ Distance (Channel 2)
Advanced Setup Transducer Block	Contains all parameters for a more detailed configuration of the device	no output values
Display Transducer Block	Contains all parameters for the configuration of the display module	no output values
Diagnostic Transducer Block	Contains diagnostic information	no output values
Expert Configuration Transducer Block	Contains parameters which require detailed knowledge of the functionalities of the device	no output values
Expert Information Transducer Block	Contains information about the state of the device	no output values
Service Sensor Transducer Block	Contains parameters which can only be operated by Endress+Hauser service personnel	no output values
Service Information Transducer Block	Contains information on the state of device which is relevant for service operations	no output values
Data Transfer Transducer Block	Contains parameters which allow to backup the device configuration in the display module and to restore it into the device.	no output values

1) depending on the configuration of the block

Function Blocks

Block	Content	Number of permanent blocks	Number of instantiable blocks	Execution time	Functionality
Resource Block	The Resource Block contains all the data that uniquely identifies the field device. It is an electronic version of a nameplate of the device.	1	0	-	enhanced
Analog Input Block	The AI block takes the manufacturer's input data, selected by channel number, and makes it available to other function blocks at its output.	2	3	25 ms	enhanced
Discrete Input Block	The DI block takes a discrete input value (e.g. indication of an level limit), and makes it available to other function blocks at its output.	1	2	20 ms	standard
PID Block	The PID block serves as proportional-integral-derivative controller and is used almost universally to do closed-loop-control in the field including cascade and feedforward.	1	1	25 ms	standard

Block	Content	Number of permanent blocks	Number of instantiable blocks	Execution time	Functionality
Arithmetic Block	This block is designed to permit simple use of popular measurement math functions. The user does not have to know how to write equations. The math algorithm is selected by name, chosen by the user for the function to be done.	1	1	25 ms	standard
Signal Characterizer Block	The signal characterizer block has two sections, each with an output that is a non-linear function of the respective input. The non-linear function is determined by a single look-up table with 21 arbitrary x-y pairs.	1	1	25 ms	standard
Input Selector Block	The input selector block provides selection of up to four inputs and generates an output based on the configured action. This block normally receives its inputs from AI blocks. The block performs maximum, minimum, middle, average and 'first good' signal selection.	1	1	25 ms	standard
Integrator Block	The Integrator Function Block integrates a variable as a function of the time or accumulates the counts from a Pulse Input block. The block may be used as a totalizer that counts up until reset or as a batch totalizer that has a setpoint, where the integrated or accumulated value is compared to pre-trip and trip settings, generating discrete signals when these settings are reached.	1	1	25 ms	standard
Analog Alarm Block		1	1	25 ms	standard

 Up to 20 blocks can be instantiated in the device altogether, including the blocks already instantiated on delivery.

Auxiliary energy

Electrical connection

2-wire, 4-20mA HART

Without integrated overvoltage protection

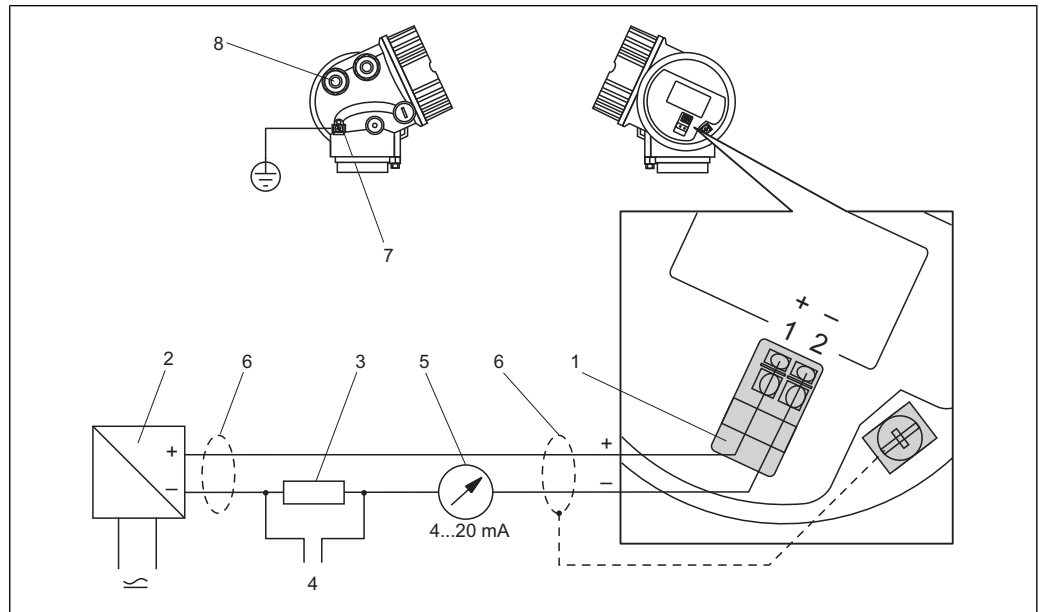

A0011294

- 1 Terminal 4...20mA HART passive
- 2 Active barrier with power supply (e.g. RN221N): Observe terminal voltage (→ 25)
- 3 HART communication resistor ($\geq 250 \Omega$): Observe maximum load (→ 28)
- 4 Connection for Field Communicator 375/475 or Commubox FXA195
- 5 Analog display device: Observe maximum load (→ 28)
- 6 Observe cable specification (→ 26)
- 7 Potential equalization
- 8 Cable entry

2-wire, 4-20 mA HART, 4...20mA

Without integrated overvoltage protection

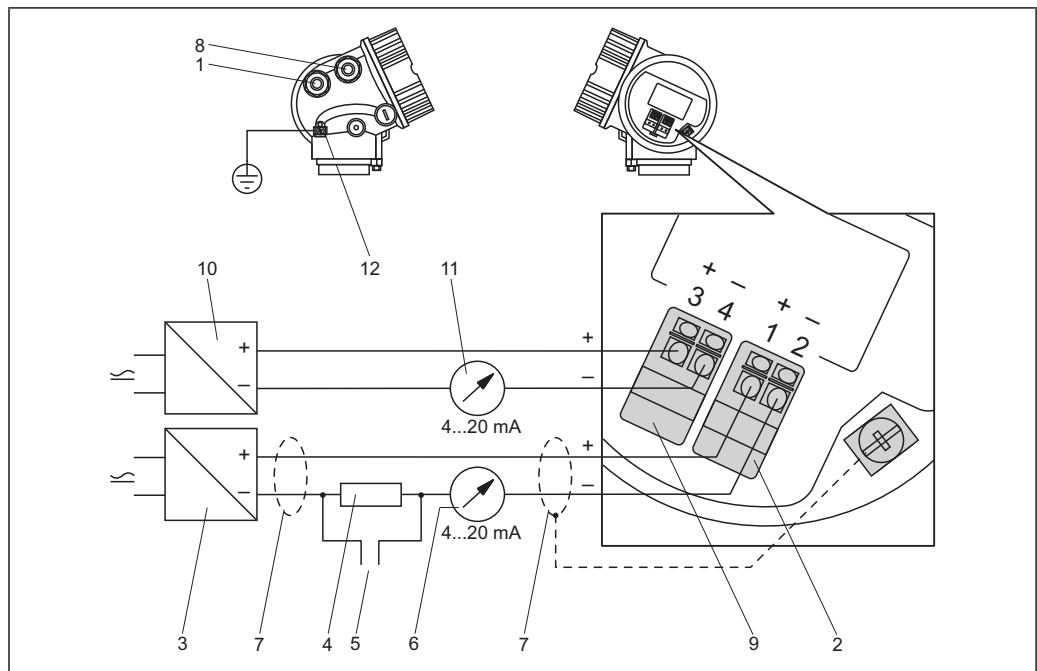

- 1 Cable entry for current output 1
- 2 Terminal for current output 1
- 3 Supply voltage for current output 1 (e.g. RN221N); Observe terminal voltage (→ 26)
- 4 HART communication resistor ($\geq 250\Omega$); Observe maximum load (→ 28)
- 5 Connection for Field Communicator 375/475 or Commubox FXA195
- 6 Analog display device ; observe maximum load (→ 28)
- 7 Observe cable specification (→ 26)
- 8 Cable entry for current output 2
- 9 Terminal for current output 2
- 10 Supply voltage for current output 2 (e.g. RN221N); Observe terminal voltage (→ 26)
- 11 Analog display device ; observe maximum load
- 12 Terminal for the potential equalization line

i This version is also suited for single-channel operation. In this case, current output 1 (terminals 1 and 2) must be used.

4-wire, 4-20 mA HART

Without integrated overvoltage protection

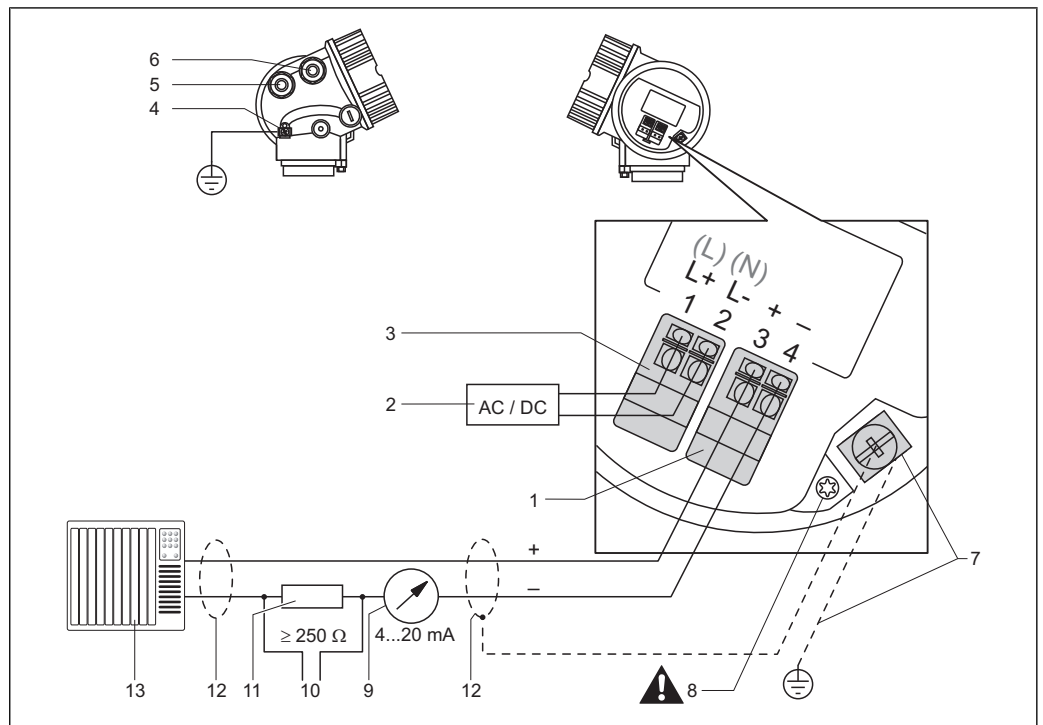

A0011340

- 1 Terminal 4...20mA HART active
- 2 Supply voltage: Observe terminal voltage (→ 26), observe cable specification (→ 26)
- 3 Terminal supply voltage
- 4 Potential equalization
- 5 Cable entry for power supply
- 6 Cable entry for signal line
- 7 Protective earth, observe cable specification (→ 26)
- 8 Protective connection; do not disconnect!
- 9 Analog display device: Observe maximum load (→ 28)
- 10 Connection Field Communicator 375/475 or Commubox FXA195
- 11 HART communication resistor ($\geq 250 \Omega$): Observe maximum load (→ 28)
- 12 Signal cable including screening (if required), observe cable specification (→ 26)
- 13 Evaluation unit, e.g. PLC

CAUTION

To ensure electrical safety:

- ▶ Do not disconnect the protective earth connection (8).
- ▶ Disconnect the supply voltage before disconnecting the protective earth (7).

- i** Connect protective earth (7) to the internal ground terminal (7) before connecting the supply voltage. If necessary, connect the potential matching line to the external ground terminal (4).
- i** In order to ensure electromagnetic compatibility (EMC): Do not only ground the device via the protective earth conductor of the supply cable. Instead, the functional grounding must also be connected to the process connection (flange or threaded connection) or to the external ground terminal.
- i** An easily accessible power switch must be installed in the proximity of the device. The power switch must be marked as a disconnector for the device (IEC/EN61010).

PROFIBUS PA

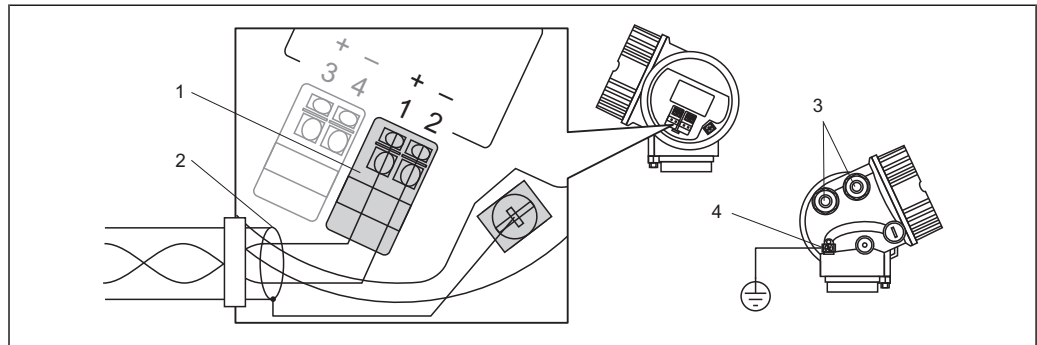

A0011341

- 1 Terminals PROFIBUS PA
- 2 Cable screen: Observe cable specifications
- 3 Cable entry
- 4 Potential equalization

FOUNDATION Fieldbus

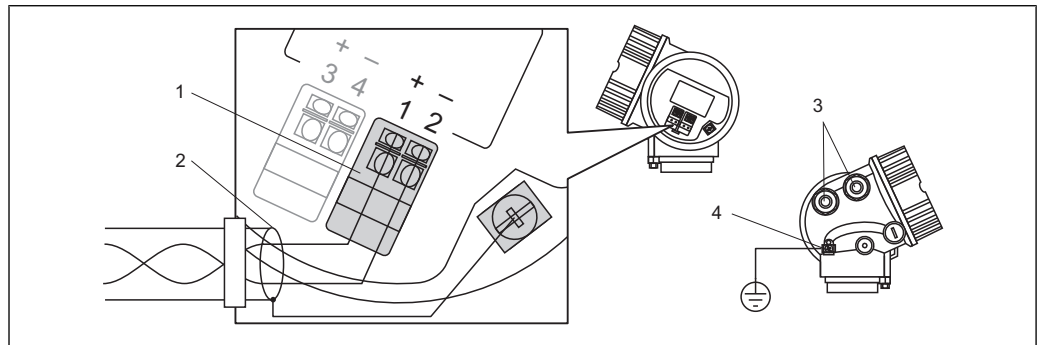

A0011341

- 1 Terminal assignment FOUNDATION Fieldbus
- 1 Terminals FOUNDATION Fieldbus
- 2 Cable screen: Observe cable specifications (→ 26)
- 3 Cable entry
- 4 Potential equalization

Switch output

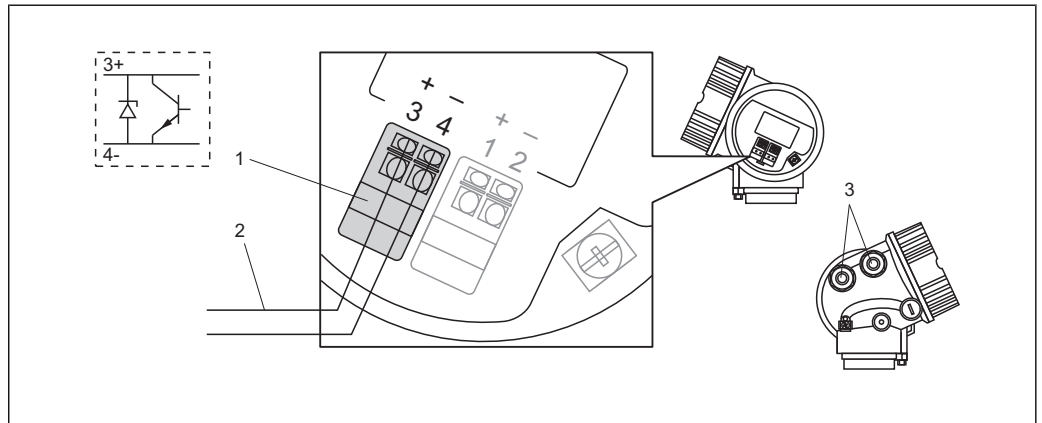

A0013759

- 1 Terminals switching output (Open collector)
- 2 Connection cable switching output
- 3 Cable entry

Switching output	
Function	Open collector switching output
Switching behavior	Binary (conductive or non-conductive), switches when the programmable switch point is reached
Failure mode	non-conductive
Electrical connection values	$U = 10.4 \text{ to } 35 \text{ V}_{\text{DC}}$, $I = 0 \text{ to } 40 \text{ mA}$
Internal resistance	$R_i < 880 \Omega$ The voltage drop at this internal resistance has to be taken into account on planning the configuration. For example, the resulting voltage at a connected relay must be sufficient to switch the relay.
Insulation voltage	floating, Insulation voltage $1 \text{ } 350 \text{ V}_{\text{DC}}$ to power supply and $500 \text{ V}_{\text{AC}}$ to ground
Switch point	freely programmable, separately for switch-on and switch-off point
Switching delay	freely programmable from 0 to 100 sec. , separately for switch-on and switch-off point
Number of switching cycles	corresponds to the measuring cycle
Signal source device variables	<ul style="list-style-type: none"> ■ Level linearized ■ Distance ■ Terminal voltage ■ Electronic temperature ■ Relative echo amplitude ■ Interface linearized ¹⁾ ■ Interface distance ¹⁾ ■ Upper interface thickness ¹⁾ ■ Relative interface amplitude ¹⁾
Number of switching cycles	unlimited

1) only if an interface measurement is active

Connection examples for the switch output

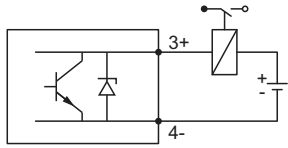
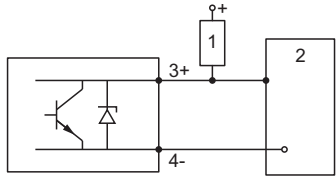
 <p style="text-align: right;">A0015909</p> <p>☑ 2 Connection of a relay</p> <p>Suitable relays (examples):</p> <ul style="list-style-type: none">■ Solid-state relay: Phoenix Contact OV-24DC/480AC/5 with mounting rail connector UMK-1 OM-R/AMS■ Electromechanical relay: Phoenix Contact PLC-RSC-12DC/21	 <p style="text-align: right;">A0015910</p> <p>☑ 3 Connection of a digital input</p> <p>1 Pull-up resistor 2 Digital input</p>
--	---

Connection HART loop converter HMX50

The dynamic variables of the HART protocol can be converted into individual 4 to 20 mA sections using the HART loop converter HMX50. The variables are assigned to the current output and the measuring ranges of the individual parameters are defined in the HMX50.

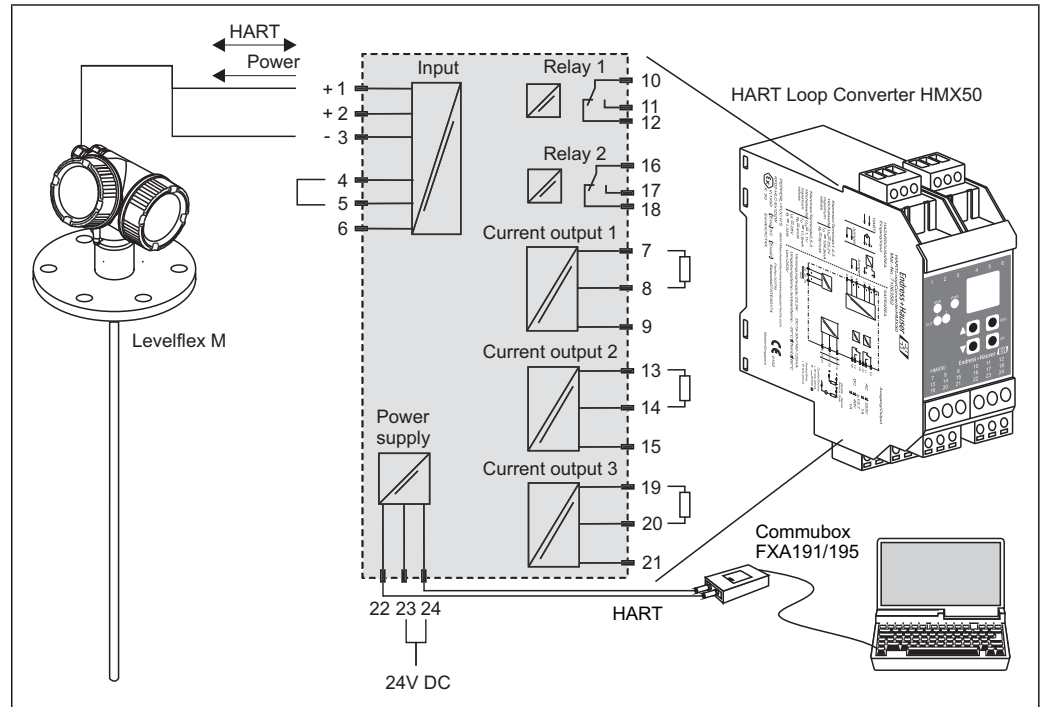

4 Connection diagram for HART loop converter HMX50 (example: passive 2-wire device and current outputs connected as power source)

The HART loop converter HMX50 can be acquired using the order number 71063562.

Additional documentation: TI429F and BA371F.

Supply voltage



An external power supply is required.

Various supply units can be ordered from Endress+Hauser: see "Accessories" section (→ 95)

2-wire, 4-20mA HART, passive

"Power Supply, Output" ¹⁾	Outputs	Terminal voltage	"Approval" ²⁾
A: 2-wire; 4-20mA HART	1	11.5 to 35 V ³⁾	Non-Ex, Ex nA, CSA GP
		11.5 to 32 V ³⁾	Ex ic
		11.5 to 30 V ³⁾	Ex ia / IS
		13.5 to 30 V ⁴⁾	Ex d / XP, Ex ic(ia), Ex tD / DIP
C: 2-wire; 4-20mA HART, 4-20mA	1	13.5 to 30 V ⁴⁾	all
	2	12 to 30 V	all

- 1) Feature 020 of the product structure
- 2) Feature 010 of the product structure
- 3) For ambient temperatures $T_a \leq -30\text{ °C}$ (-22 °F) a minimum voltage of 14 V is required for the startup of the device at the MIN error current (3.6 mA). The startup current can be parametrized. If the device is operated with a fixed current $I \geq 4.5\text{ mA}$ (HART multidrop mode), a voltage of 10,4 V is sufficient throughout the entire range of ambient temperatures.
- 4) For ambient temperatures $T_a \leq -30\text{ °C}$ (-22 °F) a minimal voltage of 16 V is required for the startup of the device at the MIN error current (3.6 mA).

 Load (→  28)

Residual ripple:

- < 1 V_{SS} (0 to 100 Hz)
- < 10 mV_{SS} (100 to 10 000 Hz)

4-wire, 4-20mA HART, active

"Power supply; Output" ¹⁾	Terminal voltage
K: 4-wire 90-253VAC; 4-20mA HART	90 to 253 V _{AC} (50 to 60 Hz), overvoltage category II
L: 4-wire 10,4-48VDC; 4-20mA HART	10.4 to 48 V _{DC}

1) Feature 020 of the product structure

PROFIBUS PA

"Power supply; Output" ¹⁾	Terminal voltage
G: 2-wire; PROFIBUS PA, switch output	9 to 32 V _{DC}

1) Feature 020 of the product structure

FOUNDATION Fieldbus

"Power supply; Output" ¹⁾	Terminal voltage
E: 2-wire; FOUNDATION Fieldbus, switch output	9 to 30 V _{DC} (Ex) 9 to 32 V _{DC} (non Ex)
Device withstanding voltage	35 V
Polarity sensitive	No
FISCO/FNICO compliant according to IEC 60079-27	Yes

1) Feature 020 der Produktstruktur

Terminals

Plug-in spring terminals for wire cross-sections 0.5 to 2.5 mm² (20 to 14 AWG)

Cable entries

- Cable gland (not for Ex d):
 - Plastics M20x1.5 with cable Ø 5 to 10 mm (0.2 to 0.39 in): non-Ex, ATEX/IECEx/NEPSI Ex ia/ic
 - Metal M20x1.5 with cable Ø 7 to 10 mm (0.28 to 0.39 in): dust-Ex, FM IS, CSA IS, CSA GP, Ex nA
- Thread for cable entry:
 - ½" NPT
 - G ½"
 - M20 × 1.5
- Connector (only for non-Ex, Ex ic, Ex ia): M12 or 7/8"

Cable specification

HART

- For ambient temperature T_U ≥ 60 °C (140 °F): use cable for temperature T_U + 20 K.
- A normal device cable suffices if only the analog signal is used.
- A shielded cable is recommended if using the HART protocol. Observe grounding concept of the plant.

PROFIBUS

Use a twisted, screened two-wire cable, preferably cable type A.

 For further information on the cable specifications, see Operating Instructions BA00034S "Guidelines for planning and commissioning PROFIBUS DP/PA", PNO Guideline 2.092 "PROFIBUS PA User and Installation Guideline" and IEC61158-2 (MBP).

FOUNDATION Fieldbus

- Endress+Hauser recommends using twisted, shielded two-wire cables.
- Terminals for wire cross-sections: 0.5 to 2.5 mm² (20 to 14 AWG)
- Cable outer diameter: 5 to 9 mm (0.2 to 0.35 in)

 For further information on the cable specifications, see Operating Instructions BA00013S "FOUNDATION Fieldbus Overview", FOUNDATION Fieldbus Guideline and IEC 61158-2 (MBP).

Device plug connectors

 For the versions with fieldbus plug connector (M12 or 7/8"), the signal line can be connected without opening the housing.

Pin assignment of the M12 plug connector

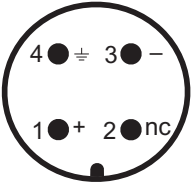
	Pin	Meaning
	1	Signal +
	2	not connected
	3	Signal -
	4	Ground

Pin assignment of the 7/8" plug connector

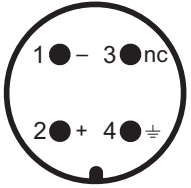
	Pin	Meaning
	1	Signal -
	2	Signal +
	3	not connected
	4	Ground

Power consumption

"Power supply; Output" ¹⁾	Power consumption
A: 2-wire; 4-20mA HART	0.9 W
C: 2-wire; 4-20mA HART, 4-20mA	2 x 0.7 W
K: 4-wire 90-253VAC; 4-20mA HART	6 VA
L: 4-wire 10,4-48VDC; 4-20mA HART	1.3 W

1) Feature 020 of the product structure

Current consumption

HART

Nominal current	3.6 to 22 mA, the start-up current for multidrop mode can be parametrized (is set to 3.6 mA on delivery)
Breakdown signal (NAMUR NE43)	adjustable: 3.59 to 22.5 mA

PROFIBUS PA

Nominal current	14 mA
Error current FDE (Fault Disconnection Electronic)	0 mA

FOUNDATION Fieldbus

Device basic current	14 mA
Error current FDE (Fault Disconnection Electronic)	0 mA

FISCO

U_i	17.5 V
I_i	500 mA; with surge arrester 273 mA
P_i	5.5 W; with surge arrester 1.2 W
C_i	5 nF
L_i	0.01 mH

Power supply failure

- Configuration is retained in the HistoROM (EEPROM).
- Error messages (incl. value of operated hours counter) are stored.

Maximum load

In order to ensure a sufficient terminal voltage at the device, the load resistance R (including wire resistance) must not exceed a value depending on the voltage U_0 supplied by the supply unit.

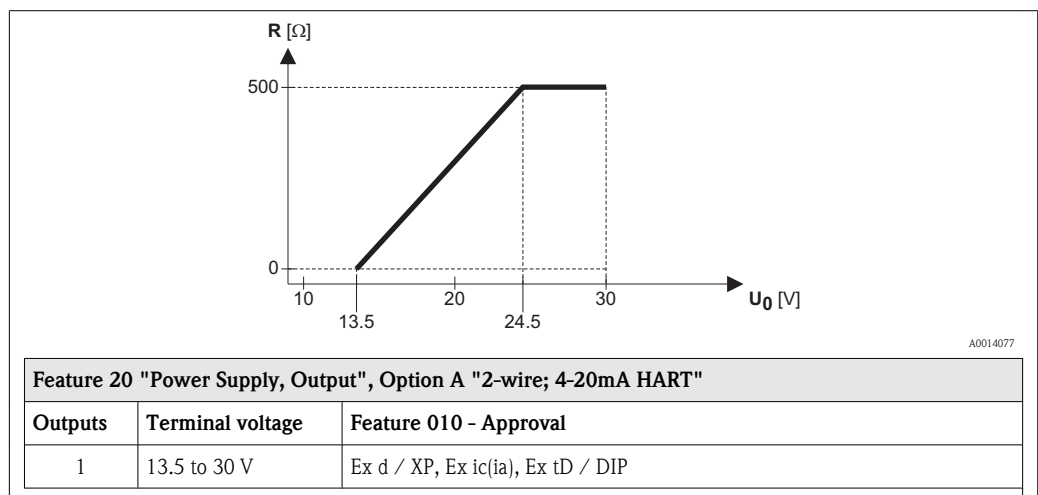
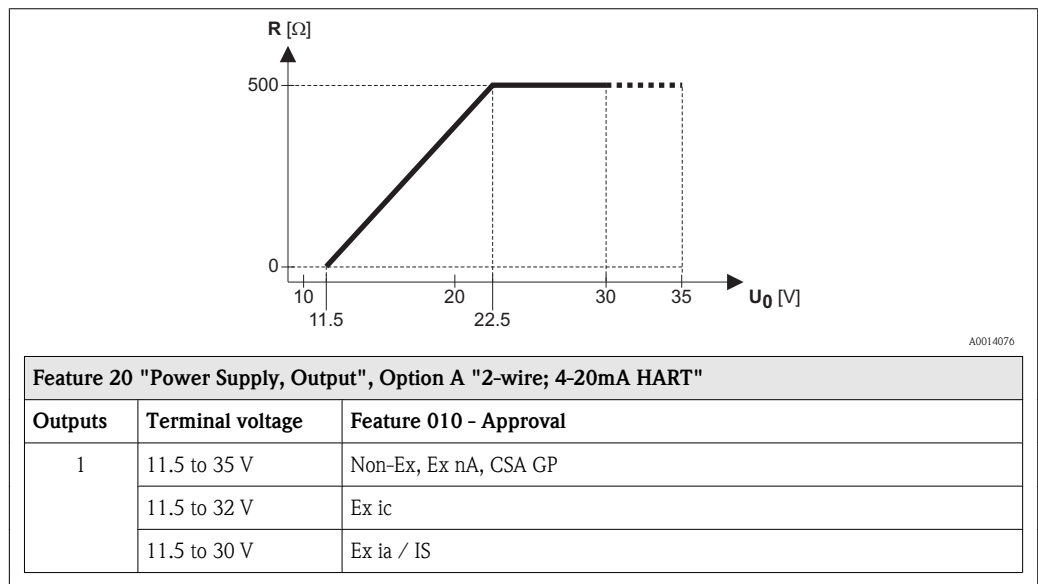

Feature 20 "Power Supply, Output", Option C "2-wire; 4-20mA HART, 4-20mA"		
Outputs	Terminal voltage	Feature 010 "Approval"
1	13.5 to 30 V	all

For 4-wire devices (feature 020, options "K" and "L") the admissible load is 0 to 500 Ω.

Potential equalization

No special measures for potential equalization are required.



If the device is designed for hazardous areas, observe the information in the documentation "Safety Instructions" (XA, ZD).

Overvoltage protection

If the measuring device is used for level measurement in flammable liquids which requires the use of overvoltage protection according to DIN EN 60079-14, standard for test procedures 60060-1 (10 kA, pulse 8/20 μs), overvoltage protection has to be ensured by one of the following measures:

- Integrated overvoltage protection (in preparation)
Product structure: Feature 610 "Accessory mounted", option NA "Overvoltage protection".
- External overvoltage protection, e.g. Endress+Hauser's HAW562 or HAW569.



For detailed information please refer to the following documents:

- HAW562: TI01012K
- HAW569: TI01013K

Performance characteristics

Reference operating conditions

- Temperature = +24 °C (+75 °F) ±5 °C (±9 °F)
- Pressure = 960 mbar abs. (14 psia) ±100 mbar (±1.45 psi)
- Humidity = 60 % ±15 %
- Reflection factor ≥ 0,8 (surface of the water for coax probe, metal plate for rod and rope probe with min. 1 mm (0.04 in) diameter)
- Flange for rod or rope probe ≥ 300 mm (12 in) diameter
- Distance to obstacles ≥ 1 m (40 in)
- For interface measurement:
 - Coax probe
 - DC of the lower medium = 80 (water)
 - DC of the upper medium = 2 (oil)

Maximum measured error

Typical data under reference operating conditions: DIN EN 61298-2, percentage values in relation to the span.

Output:	digital	analog ¹⁾
Sum of non-linearity, nonrepeatability and hysteresis	Level measurement: <ul style="list-style-type: none"> ■ Measuring range up to 15 m (49 ft): ±2 mm (0.08 in) ■ Measuring range >15 m (49 ft): ±10 mm (0.39 in) ■ FMP54 with coax probe: ±5 mm (0.2 in) 	±0.02 %
	Interface measurement: <ul style="list-style-type: none"> ■ Measuring range up to 500 mm (19.7 in): ±20 mm (0.79 in) ■ Measuring range >500 mm (19.7 in): ±10 mm (0.39 in) ■ If the thickness of the upper medium is <100 mm (3.94 in): ±40 mm (1.57 in) 	
Offset / Zero	±4 mm (0.16 in)	±0.03 %

1) Add error of the analogous value to the digital value.

If the reference conditions are not met, the offset/zero point arising from the mounting situation may be up to ±12 mm (0.47 in) for rope and rod probes. This additional offset/zero point can be compensated for by entering a correction (parameter "level correction") during commissioning.

Differing from this, the following measuring error is present in the vicinity of the lower probe end:

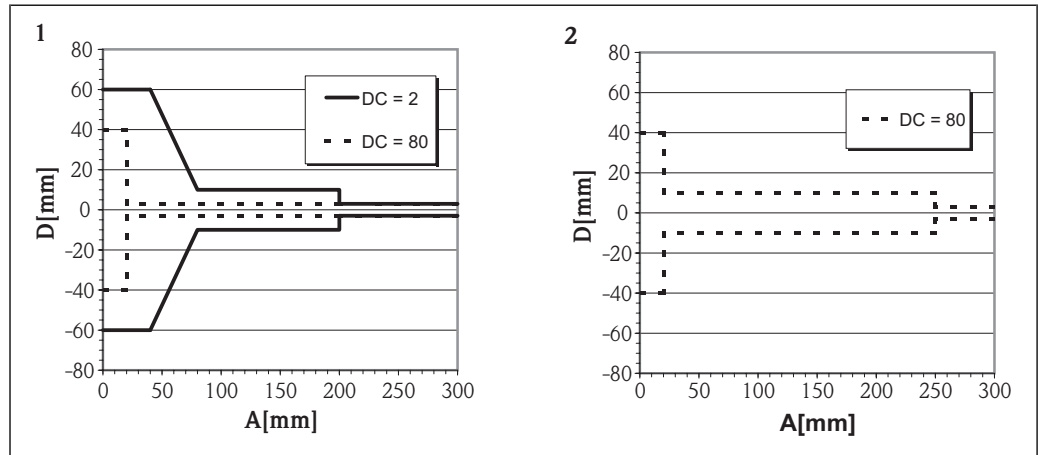

A0016586

- 1 Rod or coax probe
- 2 Rope probe
- A Distance from probe end
- D Sum of non-linearity, non-repeatability and hysteresis

If for rope probes the DC value is less than 7, then measurement is not possible in the area of the straining weight (0 to 250 mm from end of probe; lower blocking distance).

Differing from this, the following measuring error is present in the vicinity of the upper probe end (rod/rope only):

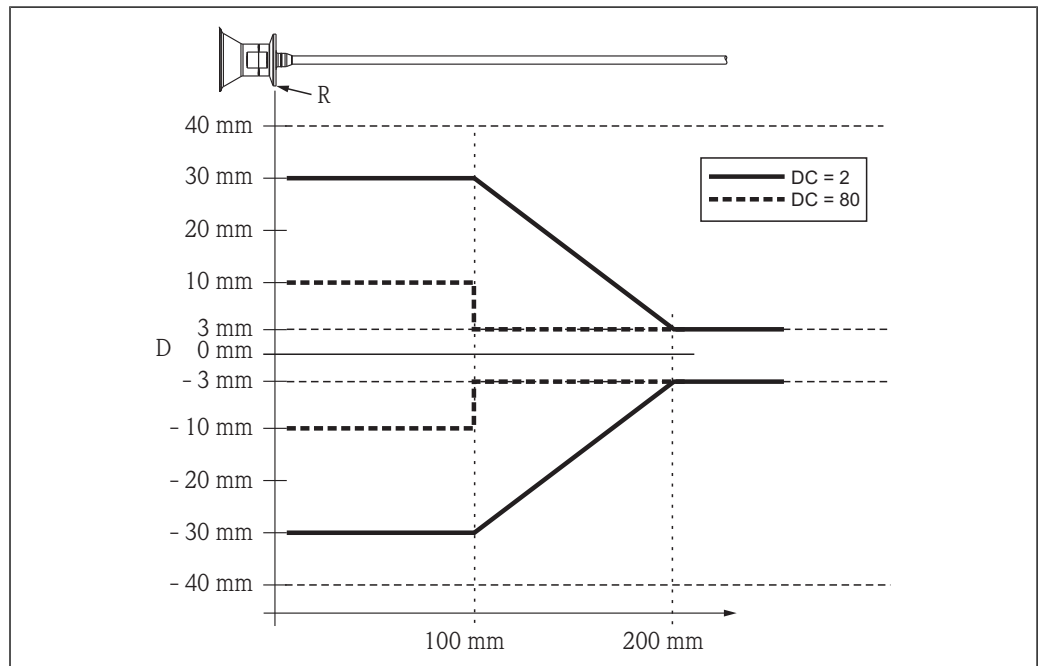

A0015091

- D Sum of non-linearity, non-repeatability and hysteresis
- R Reference point of measurement
- DC Dielectric constant

Resolution

- digital: 1 mm
- analog: 1 μ A

Reaction time

The reaction time can be parametrized. The following step response times (as per DIN EN 61298-2)²⁾ are valid if the damping is switched off:

Level measurement		
Probe length	Sampling rate	Step response time
< 10 m (33 ft)	3.6 measurements/second	< 0.8 s
< 40 m (131 ft)	≥ 2.7 measurements/second	< 1 s

Interface measurement		
Probe length	Sampling rate	Step response time
< 10 m (33 ft)	≥ 1.1 measurements/second	< 2.2 s

Influence of ambient temperature

The measurements are carried out in accordance with EN 61298-3

- digital (HART, PROFIBUS PA): average $T_K = 0.6 \text{ mm}/10 \text{ K}$
- analog (current output):
 - zero point (4 mA): average $T_K = 0.02 \text{ } \%/10 \text{ K}$
 - span (20 mA): average $T_K = 0.05 \text{ } \%/10 \text{ K}$

Influence of gas layer

High pressures reduce the propagation velocity of the measuring signals in the gas/vapor above the fluid. This effect depends on the kind of gas/vapor and of its temperature. This results in a systematic measuring error that gets bigger as the distance increases between the reference point of the measurement (flange) and the product surface. The following table illustrates this measured error for a few typical gases/vapors (with regard to distance; a positive value means that too large a distance is being measured):

Gas layer	Temperature		Pressure					
	°C	°F	1 bar (14.5 psi)	10 bar (145 psi)	50 bar (725 psi)	100 bar (1450 psi)	200 bar (2900 psi)	400 bar (5800 psi)
Air	20	68	0.00 %	0.22 %	1.2 %	2.4 %	4.9 %	9.5 %
	200	392	-0.01 %	0.13 %	0.74 %	1.5 %	3.0 %	6.0 %
	400	752	-0.02 %	0.08 %	0.52 %	1.1 %	2.1 %	4.2 %
Hydrogen	20	68	-0.01 %	0.10 %	0.61 %	1.2 %	2.5 %	4.9 %
	200	392	-0.02 %	0.05 %	0.37 %	0.76 %	1.6 %	3.1 %
	400	752	-0.02 %	0.03 %	0.25 %	0.53 %	1.1 %	2.2 %

Gas layer	Temperature		Pressure							
	°C	°F	1 bar (14.5 psi)	2 bar (29 psi)	5 bar (72.5 psi)	10 bar (145 psi)	20 bar (290 psi)	50 bar (725 psi)	100 bar (1450 psi)	200 bar (2900 psi)
Water (saturated steam)	100	212	0.26 %	-	-	-	-	-	-	-
	120	248	0.23 %	0.50 %	-	-	-	-	-	-
	152	306	0.20 %	0.42 %	1.14 %	-	-	-	-	-
	180	356	0.17 %	0.37 %	0.99 %	2.10 %	-	-	-	-
	212	414	0.15 %	0.32 %	0.86 %	1.79 %	3.9 %	-	-	-
	264	507	0.12 %	0.26 %	0.69 %	1.44 %	3.0 %	9.2 %	-	-
	311	592	0.09 %	0.22 %	0.58 %	1.21 %	2.5 %	7.1 %	19.3 %	-
	366	691	0.07 %	0.18 %	0.49 %	1.01 %	2.1 %	5.7 %	13.2 %	76 %

2) According to DIN EN 61209-2 the response time is the time which passes after a sudden change of the input signal until the output signal for the first time assumes 90% of the steady-state value.

Gas phase compensation with external pressure sensor (PROFIBUS PA)

PROFIBUS devices can receive the signal of an external pressure sensor through the bus and use it to perform a pressure dependent time-of-flight correction. In the case of saturated steam in the temperature range from 100 to 350 °C (212 to 662 °f), for example, the measuring error of the distance measurement can be reduced by this method from up to 29 % (without compensation) to less than 3 % (with compensation).

Gas phase compensation with reference signal (option for FMP54)

Under high pressure the propagation speed of microwave signals is reduced in the steam (polar media) above the liquid to be measured. As a result, the Levelflex indicates the level too low.

As an option Levelflex is available in a version with automatic gas phase correction, which corrects this error (feature 540 "Application Package", option EF: "Gas Phase Compensation $L_{ref}= 300\text{ mm}$ " or EG: "Gas Phase Compensation $L_{ref}= 550\text{ mm}$ "). This version of the Levelflex generates a reference reflection in the distance L_{ref} from the flange by a diameter step of the probe rod. The reference reflection must be at least 150 mm (6") above the highest level. By means of the shift of the reference reflection the actual propagation speed is measured and the level value will be automatically corrected.

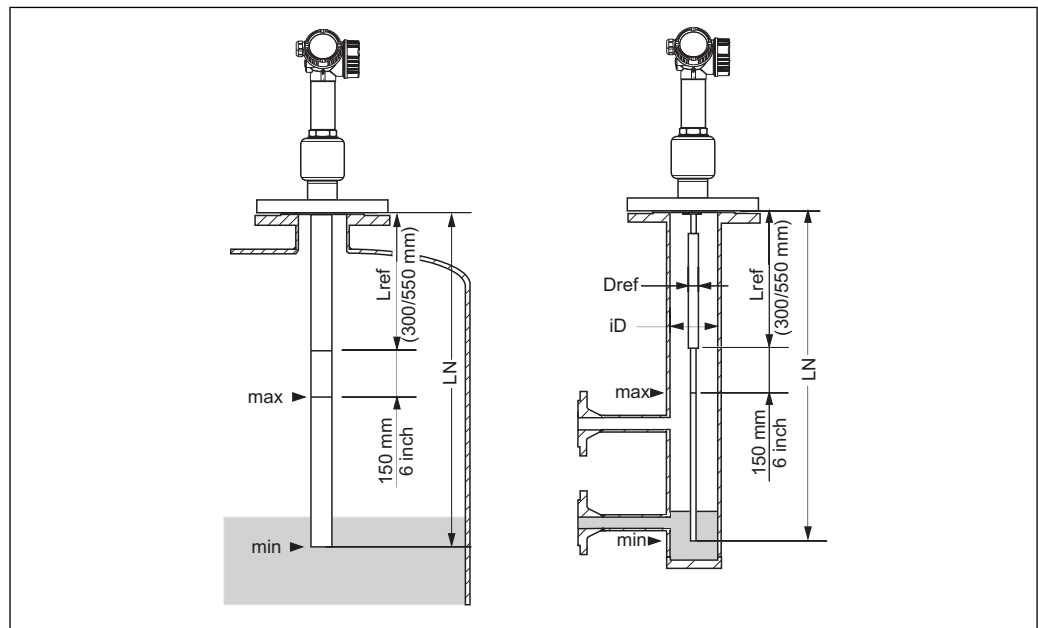

A0014534

i **Coax probes** with reference reflection can be installed in any tank (free in the tank or into a bypass). Coax probes are completely mounted and adjusted ex works. After mounting they are ready for use, additional settings are not necessary.

i **Rod probes** are only recommended if the installation of a coax probe is not possible (e.g. if the bypass diameter is too small).

Rod probes with reference reflection are only suited for mounting in stilling wells and side gauges (bypasses). The diameter D_{ref} of the probe rod in the range of the reference distance L_{ref} must be chosen depending on the pipe inner diameter iD , see table below. In the range of the reference distance L_{ref} the pipe has to be cylindrical; changes of the cross section, for example at flanged connections, are only allowed up to 5% of the inside diameter iD .

Additionally, the settings must be checked by an expert person after mounting and corrected if necessary.

Inner diameter iD of the stilling well/bypass	Diameter D_{ref} of the rod probe within the reference distance L_{ref}
40 mm (1.57") $\leq iD < 45$ mm (1.77")	22 mm (0.87")
45 mm (1.77") $\leq iD < 70$ mm (2.76")	25 mm (0.98")
70 mm (2.76") $\leq iD < 100$ mm (3.94")	30 mm (1.18")

Limitations for coax/rod probes

Maximum probe length LN	$LN \leq 4000 \text{ mm (157")}$
Minimum probe length LN	$LN > L_{ref} + 200 \text{ mm (} L_{ref} + 7.7\text{")}$
Reference distance L_{ref}	300 mm (11.8") or 550 mm (21.7"), see feature 540 of the product structure
Maximum level relative to sealing surface of flange	$L_{ref} + 150 \text{ mm (} L_{ref} + 6\text{")}$
Minimum dielectric constant of the medium	$DC > 7$

Area of application

Level measurements with high pressure for measuring ranges up to a few meters in polar media with a dielectric constant $DC > 7$ (e.g. water or ammonia), which would cause a high measuring error without the compensation.

The accuracy of measurement at reference conditions is the higher the larger the reference length L_{ref} and the smaller the measuring range is:

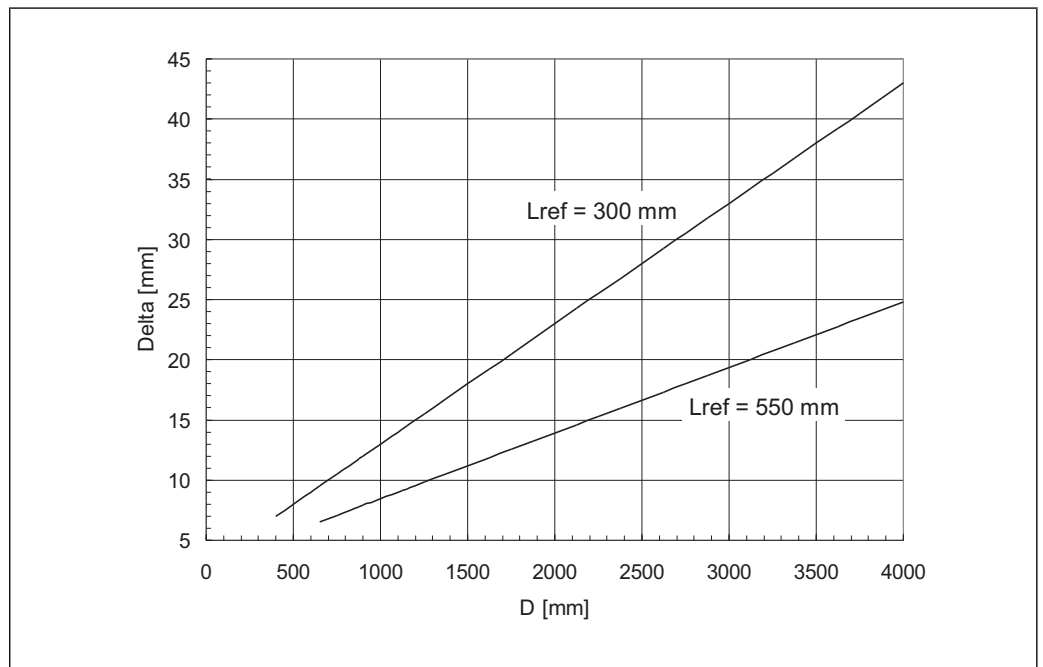

A0014535

D Distance from liquid surface to lower edge of the flange
Delta Measuring error

If there are fast changes in pressure, there may be an additional error, since the measured reference distance is filtered with the time constant of the level measurement. In addition, conditions of imbalance - for example due to heating - may cause density gradients within the medium and condensation of steam at the probe. As a result, the level readings at different locations inside the tank may vary slightly. Caused by this application influences the measuring error may be increased by a factor up to 2 to 3.

Operating conditions: Installation

Suitable mounting position

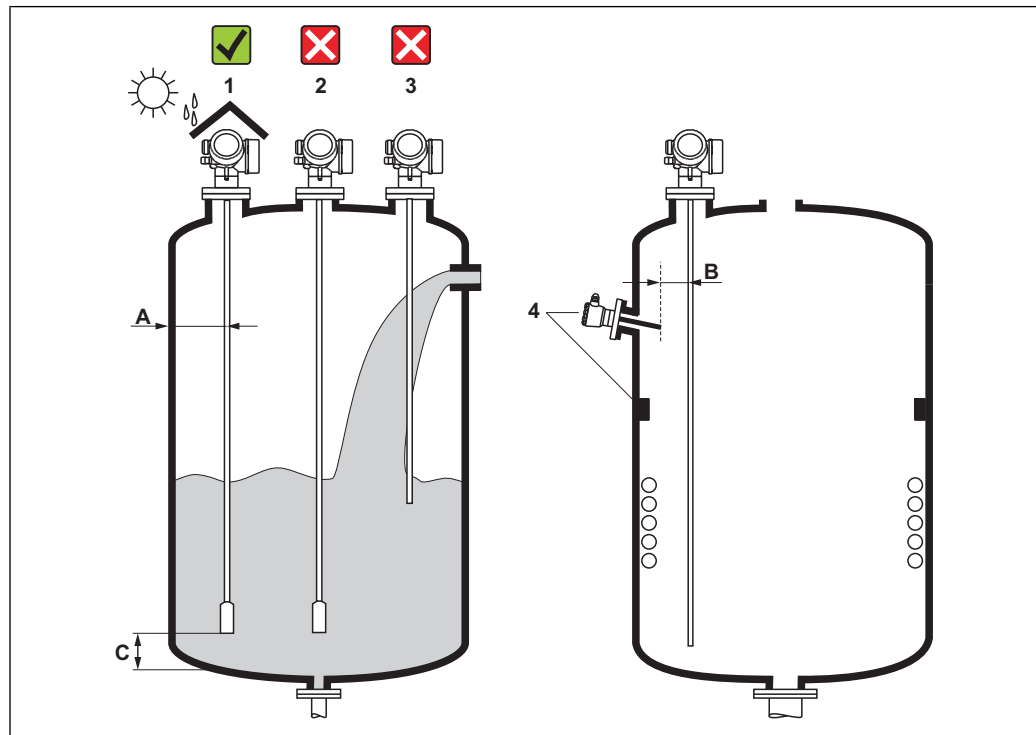

A0012606

Mounting distances

- Distance (A) between wall and rod or rope probe:
 - for smooth metallic walls: > 50 mm (2")
 - for plastic walls: > 300 mm (12") mm to metallic parts outside the vessel
 - for concrete walls: > 500 mm (20") , otherwise the available measuring range may be reduced.
- Distance (B) between rod or rope probe and internal fittings in the vessel: > 300 mm (12")
- Distance (C) from end of probe to bottom of the vessel:
 - Rope probe: > 150 mm (6 in)
 - Rod probe: > 10 mm (0.4 in)
 - Coax probe: > 10 mm (0.4 in)

i For coax probes the distance to the wall and to internal fittings is arbitrary.

Additional conditions

- When mounting in the open, a weather protection cover (1) may be installed to protect the device against extreme weather conditions.
- In metallic vessels: Preferably do not mount the probe in the center of the vessel (2), as this would lead to increased interference echoes.
If a central mounting position can not be avoided, it is crucial to perform an interference echo suppression(mapping) after the commissioning of the device.
- Do not mount the probe in the filling curtain (3).
- Avoid buckling the rope probe during installation or operation (e.g. through product movement against silo wall) by selecting a suitable mounting location.

i With suspended rope probes (probe end not fixed at the bottom) the distance between the probe rope and internal fittings in the tank must not fall below 300 mm (12") during the entire process. A sporadic contact between the probe weight and the cone of the vessel, however, does not influence the measurement as long as the dielectric constant of the medium is at least $DC = 1.8$.

i When mounting the electronics housing into a recess (e.g. in a concrete ceiling), observe a minimum distance of 100 mm (4 inch) between the cover of the terminal compartment / electronics compartment and the wall. Otherwise the connection compartment / electronics compartment is not accessible after installation.

Applications with restricted mounting space

Mounting with remote sensor

The device version with a remote sensor is suited for applications with restricted mounting space. In this case the electronics housing is mounted at a separate position from which it is easier accessible.

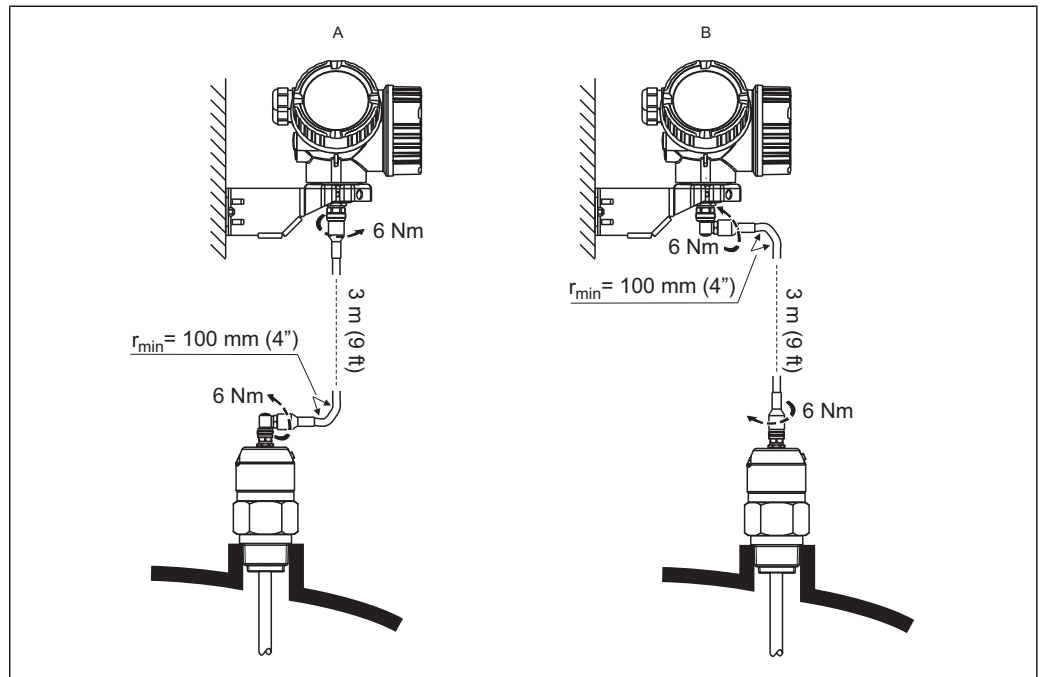

A Angled plug at the probe
 B Angled plug at the electronics housing

- Levellflex version (see product structure):
 Feature 600 "Probe Design", Option MB "Sensor remote, 3m/9ft cable, detachable+mounting bracket" (→ 86)
- A connecting cable is supplied with this device version
 - Length: 3 m (9 ft)
 - Minimum bending radius: 100 mm (4 inch)
- A mounting bracket for the electronics housing is supplied with this device version. Mounting options:
 - Wall mounting
 - Pipe mounting; diameter: 42 to 60 mm (1-1/4 to 2 inch)
- The connection cable has got one straight and one angled plug (90°). Depending on the local conditions the angled plug can be connected at the probe or at the electronics housing.

Divisible probes

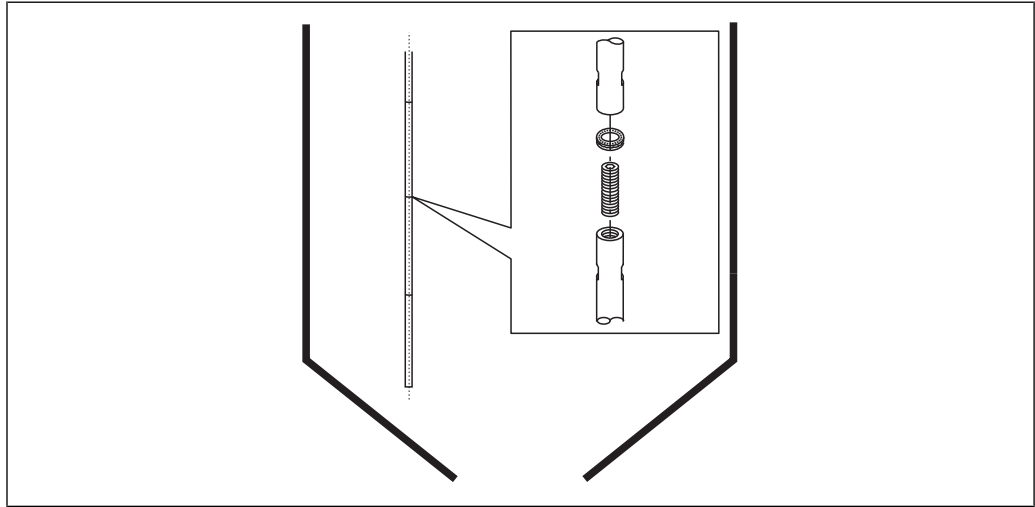

A0014148

If there is little mounting space (distance to the ceiling), it is advisable to use divisible rod probes (Ø 16 mm).

- max. probe length 10 m/394 inch
- max. sideways capacity 20 Nm
- probes are separable several times with the lengths:
 - 500 mm/20 inch
 - 1000 mm/ 40 inch
- torque: 15 Nm

Notes on the mechanical load of the probe

Tensile load limit of rope probes

Sensor	Feature 060	Probe	Tensile load limit [kN]
FMP51	LA, LB MB, MD	Rope 4mm (1/6") 316	5
FMP52	OA, OB, OC, OD	Rope 4mm (1/6") PFA>316	2
FMP54	LA, LB	Rope 4mm (1/6") 316	10

Bending strength of rod probes

Sensor	Feature 060	Probe	Bending strength [Nm]
FMP51	AA, AB	Rod 8mm (1/3") 316L	10
	AC, AD	Rod 12mm (1/2") 316L	30
	AL, AM	Rod 12mm (1/2") AlloyC	30
	BA, BB, BC, BD	Rod 16mm (0.63") 316L divisible	30
FMP52	CA, CB	Rod 16mm (0.63") PFA>316L	30
FMP54	AE, AF	Rod 16mm (0.63") 316L	30
	BA, BB, BC, BD	Rod 16mm (0.63") 316L divisible	30

Bending load (torque) through fluid flow

The formula for calculating the bending torque M impacting on the probe:

$$M = c_w \cdot \rho / 2 \cdot v^2 \cdot d \cdot L \cdot (L_N - 0.5 \cdot L)$$

with:

c_w : Friction factor

- ρ [kg/m³]: Density of the medium
- v [m/s]: Velocity of the medium perpendicular to the probe rod
- d [m]: Diameter of the probe rod
- L [m]: Level
- L_N [m]: Probe length

Calculation example

- Friction factor c_w 0,9 (on the assumption of a turbulent current - high Reynolds number)
- Density ρ [kg/m³] 1000 (e.g. water)
- Probe diameter d [m] 0,008
- $L = L_N$ (worst case)

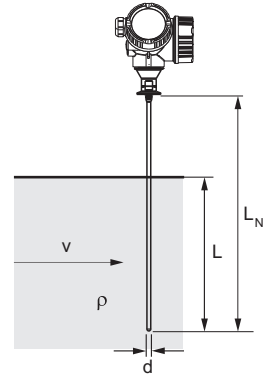

A0014175

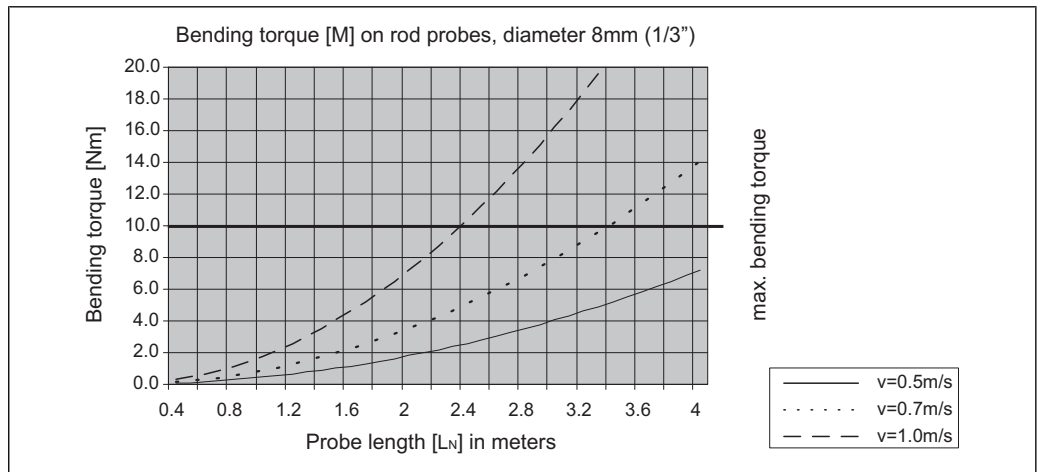

A0014182-EN

Bending strength of coax probes

Sensor	Feature 060	Process connection	Probe	Bending strength [Nm]
FMP51	UA, UB	Thread G $\frac{3}{4}$ oder NPT $\frac{3}{4}$	Coax 316L, \varnothing 21,3 mm	60
		<ul style="list-style-type: none"> ■ Thread G1$\frac{1}{2}$ or NPT1$\frac{1}{2}$ ■ Flange 	Coax 316L, \varnothing 42,4 mm	300
	UC, UD	Flange	Coax AlloyC, \varnothing 42,4 mm	300
FMP54	UA, UB	<ul style="list-style-type: none"> ■ Thread G1$\frac{1}{2}$ or NPT1$\frac{1}{2}$ ■ Flange 	Coax 316L, \varnothing 42,4 mm	300

Notes on the process connection

Probes are mounted to the process connection with threaded connections or flanges. If during this installation there is the danger that the probe end moves so much that it touches the tank floor or cone at times, the probe must, if necessary, be shortened and fixed down (→ 40).

Threaded connection

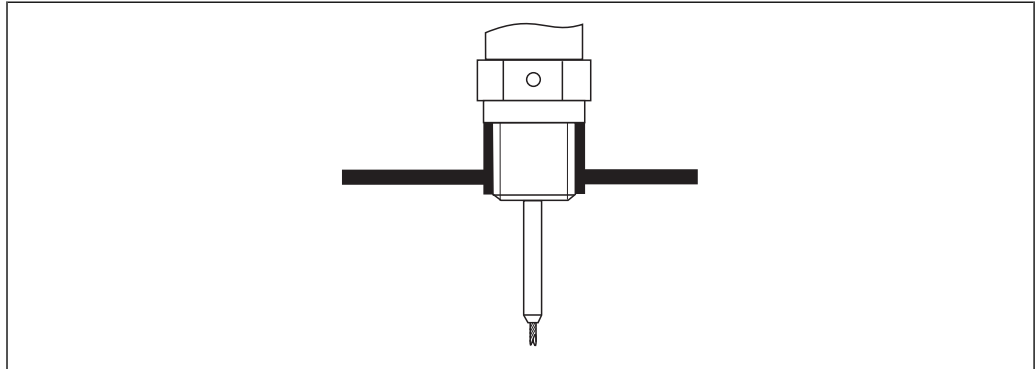

A0015121

 5 *Mounting with threaded connection; flush with the container ceiling*

Seal



The thread as well as the type of seal comply to DIN 3852 Part 1, screwed plug form A.

They can be sealed with the following types of sealing rings:

- Thread G3/4": According to DIN 7603 with the dimensions 27 x 32 mm
- Thread G1-1/2": According to DIN 7603 with the dimensions 48 x 55 mm

Please use a sealing ring according to this standard in the form A, C or D and of a material that is resistant to the application.

 **For the length of the screwed plug refer to the dimensional drawing:**

- FMP51: (→  63)
- FMP54: (→  67)

Nozzle mounting with flange

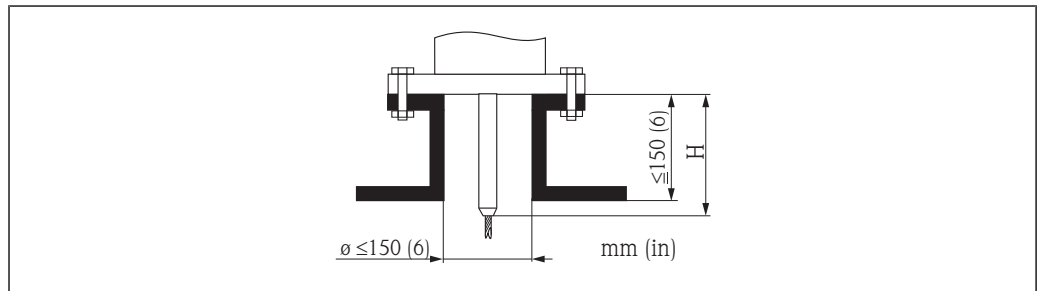

A0015122

 For FMP52: Use spring washers in order to compensate a possible creep deformation of the PTFE cladding between the tank and the device flange; see figure below.

Alternative: Retighten the flange bolts periodically, depending on process temperature and pressure.
Recommended torque: 60 to 100 Nm (44.3 to 73.7 lbf ft).

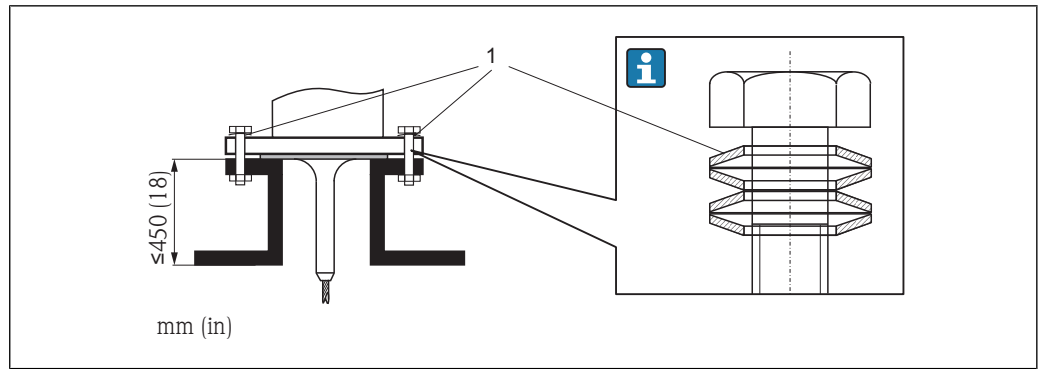

1 Spring washers ensure sufficient preload between the tank and the flange of the FMP52.

Height and diameter of the nozzle

- Permissible nozzle diameter: ≤ 150 mm (6 in).
For larger diameters the near range measuring capability may be reduced.
For nozzles ≥ DN300: .
- Permissible nozzle height ³⁾: ≤ 150 mm (6 in).
For a larger height the near range measuring capability may be reduced.
Larger nozzle heights may be possible in special cases (see sections "Center rod for FMP51 and FMP52" and "Rod extension/centering HMP40 for FMP54").

i With thermally insulated vessels the nozzle should also be insulated in order to prevent condensate formation.

Center rod for FMP51 and FMP52

For rope probes it may be necessary to use a version with center rod in order to prevent the probe rod from coming into contact with the nozzle wall. Probes with center rod are available for FMP51 and FMP52.

Probe	Max. nozzle height (= length of the center rod)	Option to be selected in feature 060 ("Probe")
FMP51	150 mm	LA
	6 inch	LB
	300 mm	MB
	12 inch	MD
FMP52	150 mm	OA
	6 inch	OC
	300 mm	OB
	12 inch	OD

Rod extension/centering HMP40 for FMP54

For FMP54 with rope probes the rod extension/centering HMP 40 is available as an accessory . It has to be used if otherwise the probe rope comes into contact with the lower edge of the nozzle.

i This accessory consists of the extension rod corresponding to the nozzle height, on which a centering disk is also mounted if the nozzles are narrow or when working in bulk solids. This component is delivered separately from the device. Please order the probe length correspondingly shorter.

Centering disks with small diameters (DN40 and DN50) may only be used if there is no significant build-up in the nozzle above the disk. The nozzle must not become clogged by the product.

Installation in nozzles ≥ DN300

If installation in ≥ 300mm/12" nozzles is unavoidable, installation must be carried out in accordance with the sketch on the right.

3) Larger nozzle heights on request

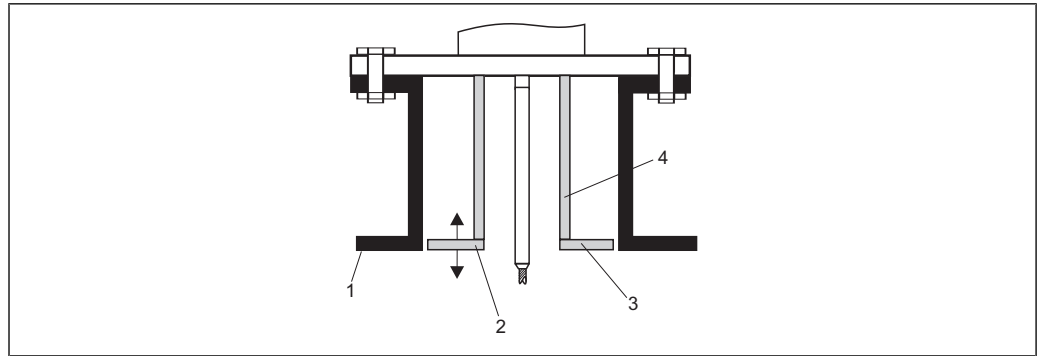

A0014199

- 1 Lower edge of the nozzle
- 2 Approx. flush with the lower edge of the nozzle ($\pm 50 \text{ mm}/2''$)
- 3 Plate
- 4 Pipe $\varnothing 150$ to 180 mm (6 to 7 inch)

Nozzle diameter	Plate diameter
300 mm (12")	280 mm (11")
$\geq 400 \text{ mm}$ (16")	$\geq 350 \text{ mm}$ (14")

Securing the probe

Securing rope probes

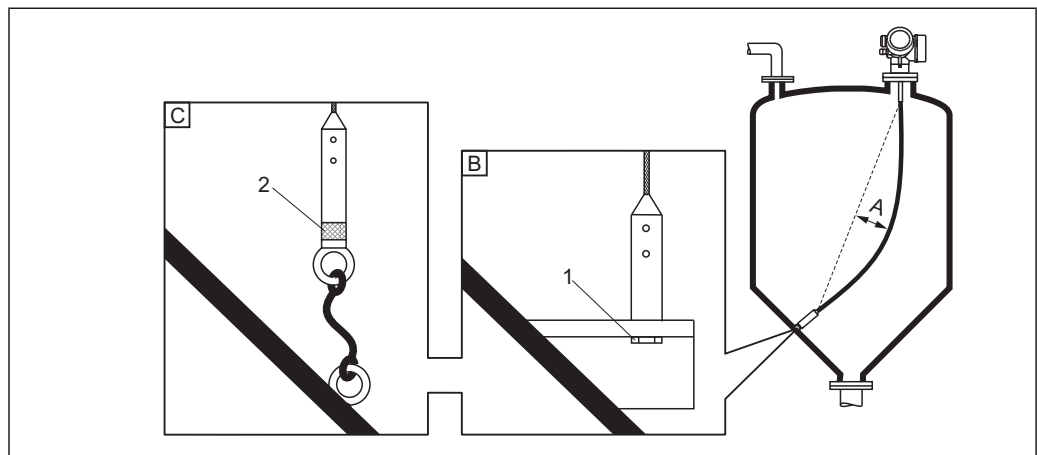

A0012009

- A Sag of the rope: $\geq 1 \text{ cm}$ per 1 m of the probe length (0.12 inch per 1 ft of the probe length)
 - B Reliably grounded end of probe
 - C Reliably isolated end of probe
- 1: Mounting and contact with a bolt
 - 2: Mounting kit isolated (\rightarrow 92)

- The end of the probe needs to be secured under the following conditions: if otherwise the probe sporadically comes into contact with the wall of the vessel, the outlet cone, internal fittings or other parts of the installation.
- The end of probe can be secured at its internal thread rope 4 mm (1/6"), 316: M 14
- The fixing must be either reliably grounded or reliably insulated. If it is not possible to mount the probe weight with a reliably insulated connection, it can be secured using an isolated eyelet, which is available as an accessory (\rightarrow 92).
- In order to prevent an extremely high tensile load (e.g. due to thermal expansion) and the risk of rope crack, the rope has to be slack. Make the rope longer than the required measuring range such that there is a sag in the middle of the rope that is $\geq 1 \text{ cm}/(1 \text{ m rope length})$ [0.12 inch/(1 ft rope length)]. Tensile load limit of rope probes:

Securing rod probes

- For Ex-approvals: For probe lengths ≥ 3 m (10 ft) a support is required.
- In general, rod probes must be supported if there is a horizontal flow (e.g. from an agitator) or in the case of strong vibrations.
- Rod probes may only be supported at the end of the probe.

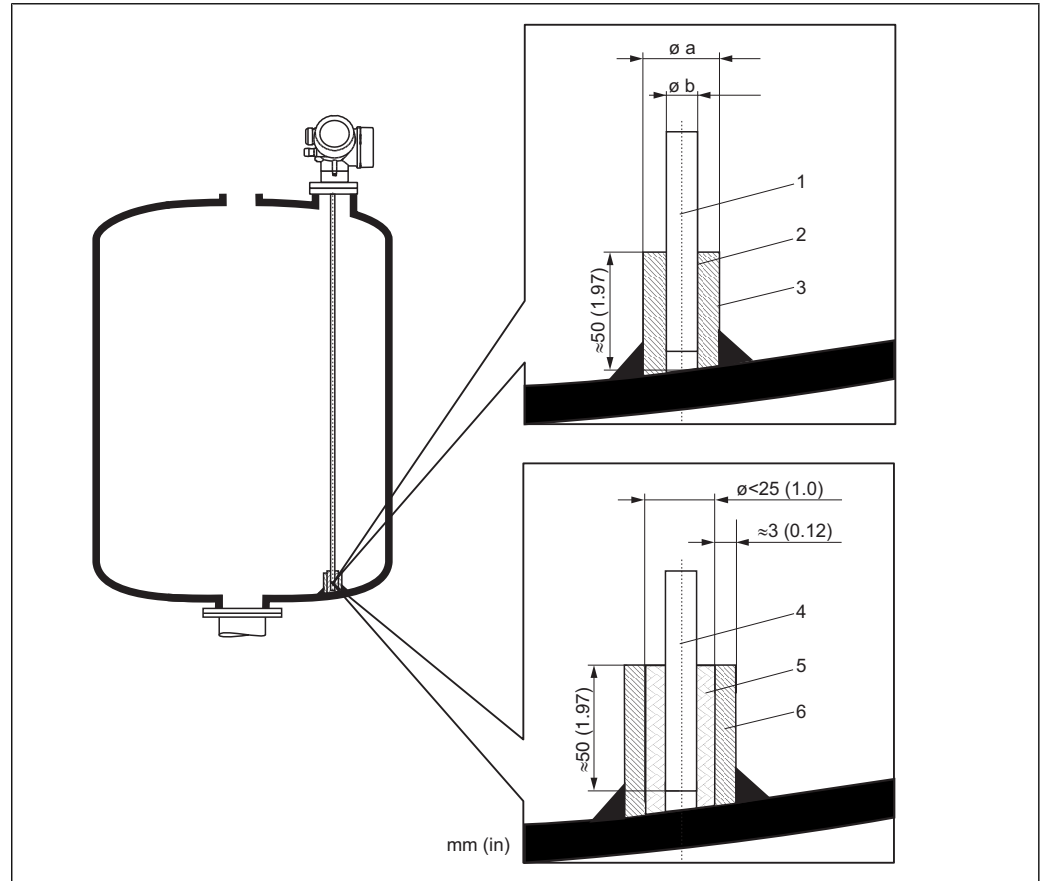

A0012607

- 1 Probe rod, uncoated
- 2 Sleeve bored tight to ensure electrical contact between the rod and sleeve!
- 3 Short metal pipe, e.g. welded in place
- 4 Probe rod, coated
- 5 Plastic sleeve, e.g. PTFE, PEEK or PPS
- 6 Short metal pipe, e.g. welded in place

\varnothing probe	$\varnothing a$ [mm (inch)]	$\varnothing b$ [mm (inch)]
8 mm (1/3")	< 14 (0.55)	8.5 (0.34)
12 mm (1/2")	< 20 (0.78)	12.5 (0.52)
16 mm (0.63in)	< 26 (1.02)	16.5 (0.65)

NOTICE

Poor grounding of the end of probe may cause measuring errors.

- ▶ Apply a narrow sleeve which has good electrical contact to the probe.

NOTICE

Welding may damage the main electronics module.

- ▶ Before welding: Ground the probe and dismount electronics.

Securing coax probes

For Ex-approvals: For probe lengths ≥ 3 m (10 ft) a support is required.

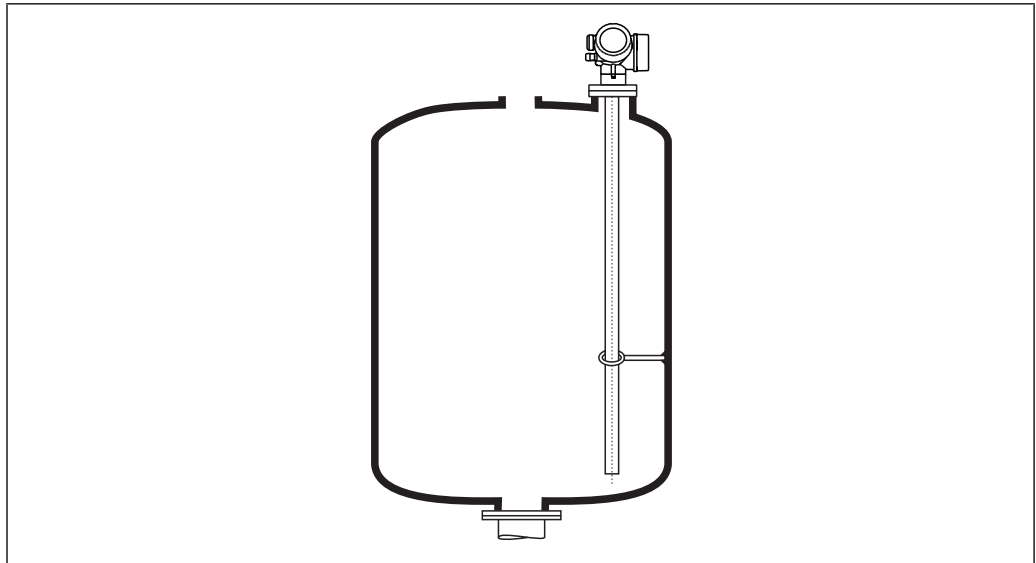

A0012608

Coax probes can be supported at any point of the outer tube.

Special mounting conditions

Installation in horizontal and upright cylindrical tanks

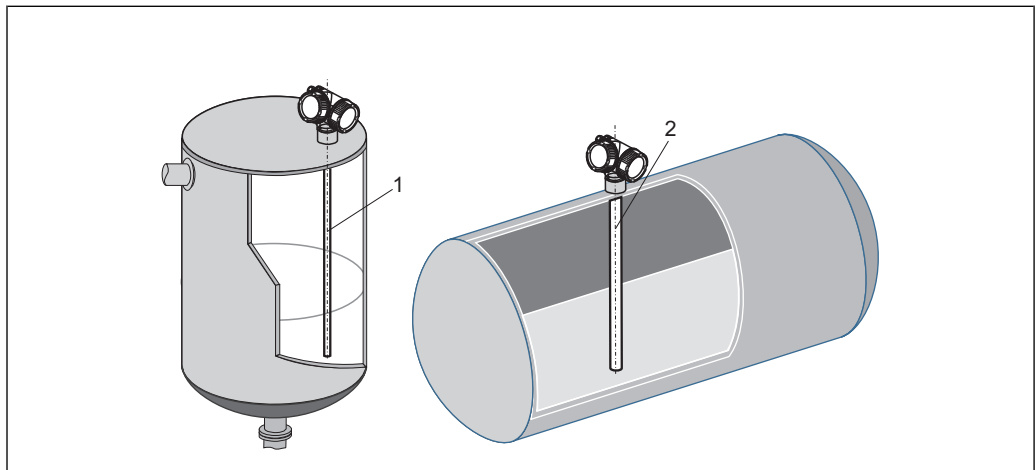

A0014141

- Any distance from wall, as long as occasional contact is prevented.
- When installing in tanks with a lot of internals or internals situated close to the probe: use a coax probe.

Bypasses and stilling wells

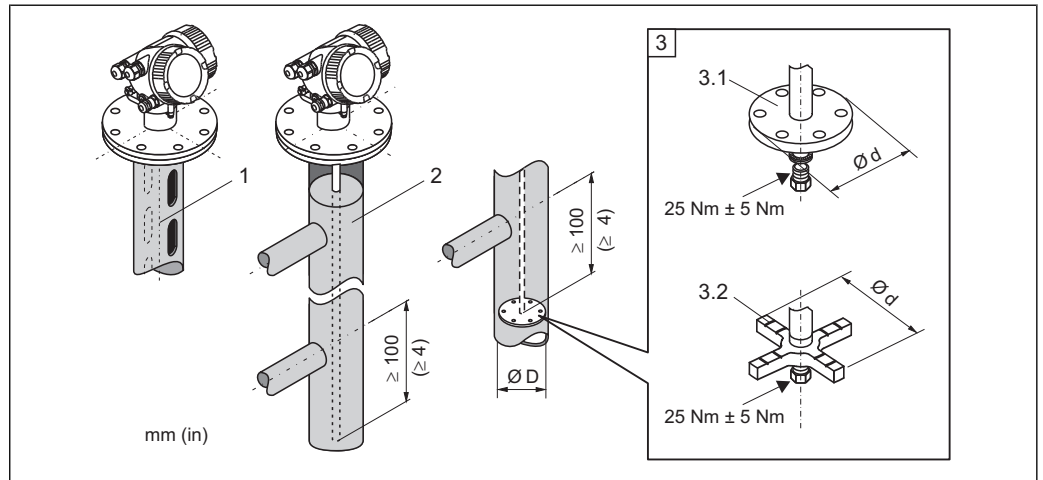

- 1 Mounting in a stilling well
- 2 Mounting in a bypass
- 3 Center washer
- 3.1 Metallic center washer (316L) for level measurement
- 3.2 Non-metallic center washer (PEEK, PFA) for interface measurement

i For information on bypass solutions from Endress+Hauser please contact your Endress+Hauser sales representative.

Feature 610 - Accessory mounted					
Application	Option	Type of probe	Center washer		Pipe
			Ø d [mm (in)]	Material	Ø D [mm (in)]
Level measurement	OA	Rod probe	75 (2,95)	316L	DN80/3" to DN100/4"
	OB	Rod probe	45 (1,77)	316L	DN50/2" to DN65/2½"
	OC	Rope probe	75 (2,95)	316L	DN80/3" to DN100/4"
Interface measurement	OD	Rod probe	48...95 (1,89...3,74)	PEEK	≥ 50 mm (2")
	OE	Rope probe	37 (1,46)	PFA	≥ 40 mm (1.57")

- Pipe diameter: > 40 mm (1.6") for rod probes
- Rod probe installation can take place up to a diameter size of 100 mm. In the event of larger diameters, a coax probe is recommended.
- Side disposals, holes or slits and welded joints that protrude up to approx. 5 mm (0.2") inwards do not influence the measurement.
- The pipe may not exhibit any steps in diameter.
- The probe must be 100 mm longer than the lower disposal.
- Within the measuring range, the probe must not get into contact with the pipe wall. If necessary, use a center washer (see feature 610 of the product structure).
- If the center washer is mounted at the end of the probe, it enables a reliable recognition of the end-of-probe signal (see feature 610 of the product structure).
- **Note:** For interface measurements only use the nonmetallic center washers made of PEEK or PFA (feature 610, options OD or OE) (→ 89).
- Coax probes can always be applied if there is enough mounting space.

- i** For bypasses with condensate formation (water) and a medium with low dielectric constant (e.g. hydrocarbons):

In the course of time the bypass is filled with condensate up to the lower disposal and for low levels the the level echo is superimposed by the condensate echo. Thus in this range the condensate level is measured instead of the correct level. Only higher levels are measured correctly. To prevent this, position the lower disposal 100 mm (4 in) below the lowest level to be measured and apply a metallic centering disk at the height of the lower edge of the lower disposal.

- i** With heat insulated tanks the bypass should also be insulated in order to prevent condensate formation.

- i** For rope probes with a length exceeding 2 m (6.7 ft) an additional weight or a spring should be mounted in addition to the center a washer (option OC) in order to tighten the rope. The mass of the center washer is 155 g (5.5 oz).

Underground tanks

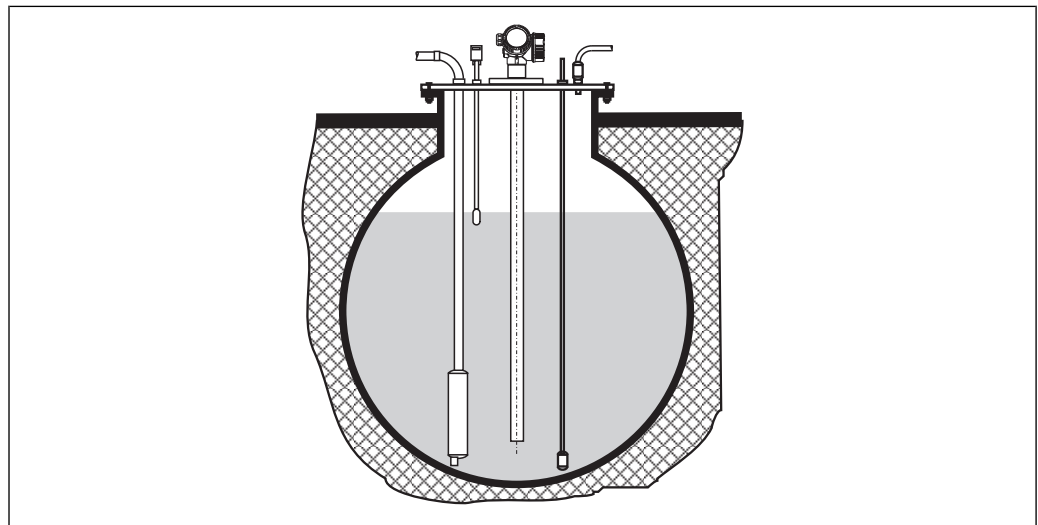

A0014142

Use a coax probe for nozzles with large diameters in order to avoid reflections at the nozzle wall.

Installation at an angle

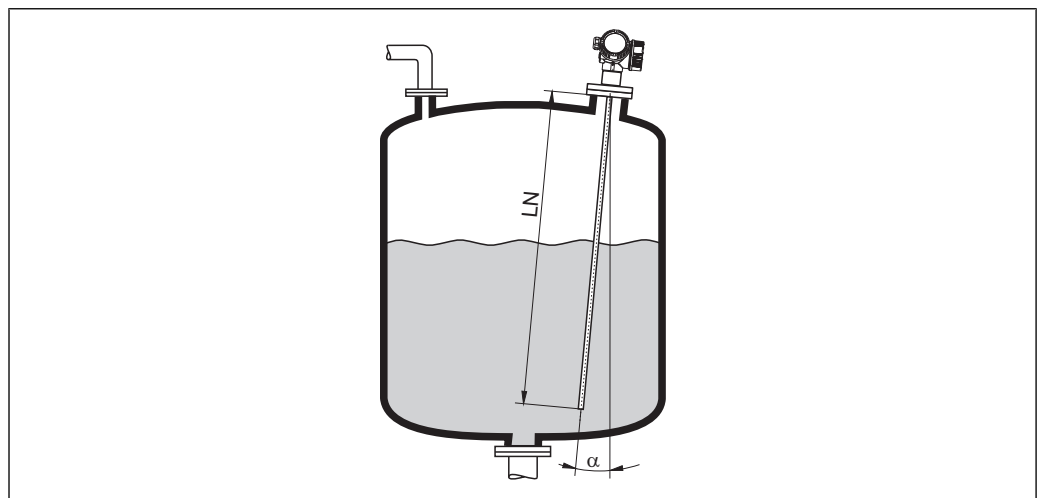

A0014145

- For mechanical reasons, the probe should be installed as vertically as possible.
- With inclined installations the probe length has to be adjusted in dependence to the installation angle.
 - Up to LN = 1 m (3.3 ft): $\alpha = 30^\circ$
 - Up to LN = 2 m (6.6 ft): $\alpha = 10^\circ$
 - Up to LN = 4 m (13.1 ft): $\alpha = 5^\circ$

Non-metallic vessels

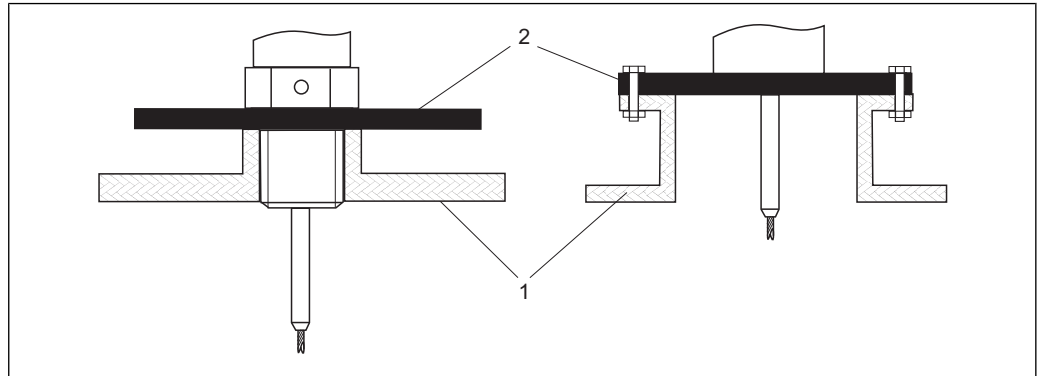

- 1 Non-metallic vessel
2 Metal sheet or metal flange

To measure, Levelflex with a rod probe needs a metallic surface at the process connection. Therefore:

- Select an instrument version with metal flange (minimum size DN50/2").
- Or: mount a metal sheet with a diameter of at least 200 mm (8") to the probe at the process connection. Its orientation must be perpendicular to the probe.

 No additional measures are required for coax probes.

Plastic or glass tanks: Mounting the probe externally at the wall

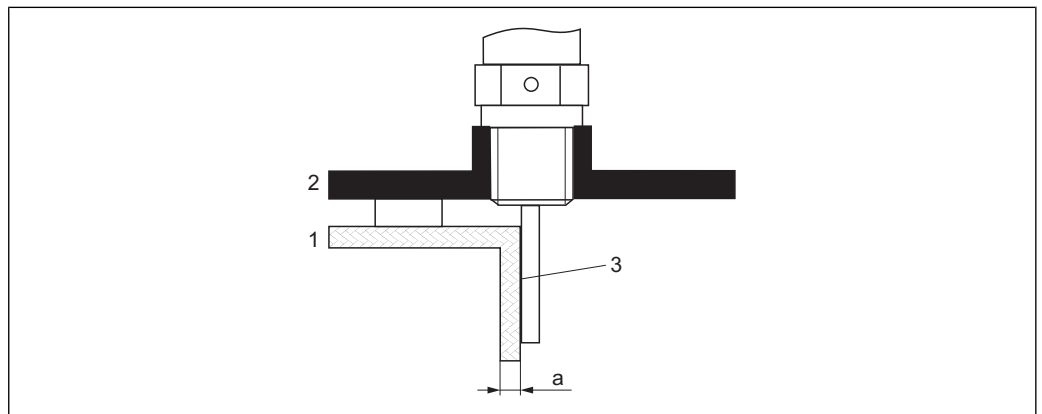

- 1 Plastic or glass tank
2 Metall sheet with threaded sleeve
3 No free space between tank wall and probe!

Requirements

- The dielectric constant of the medium must be at least $DC > 7$.
- The tank wall must be non-conductvie.
- Maximum wall thickness (a):
 - Plastic: < 15 mm (0.6")
 - Glass: < 10 mm (0.4")
- There may be no metallic reinforcements fixed to the tank.

Mounting conditions:

- The probe must be mounted directly to the tank wall (no open space)
- A plastic half pipe with a diameter of approx. 200 mm (8"), or some other protective unit, must be affixed externally to the probe to prevent any influences on the measurement.
- If the tank diameter is less than 300 mm (12"):
 - A metallic grounding sheet must be installed at the opposite side of the tank. The sheet must be conductively connected to the process connection and cover about the half of the vessel's circumference.
- If the tank diameter exceeds 300 mm (12"):
 - A metal sheet with a diameter of at least 200 mm (8") must be mounted to the probe at the process connection. Its orientation must be perpendicular to the probe (see above).

Vessels with heat insulation

i If process temperatures are high, the device must be included in normal tank insulation to prevent the electronics heating up as a result of heat radiation or convection. The insulation may not exceed beyond the points labeled "MAX" in the drawings.

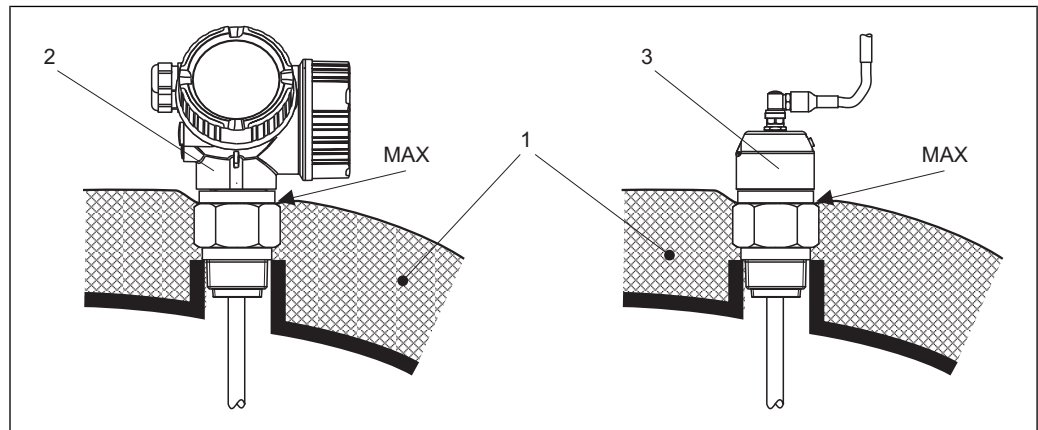

A0014653

6 Process connection with thread - FMP51

- 1 Tank insulation
- 2 Compact device
- 3 Sensor remote (feature 600)

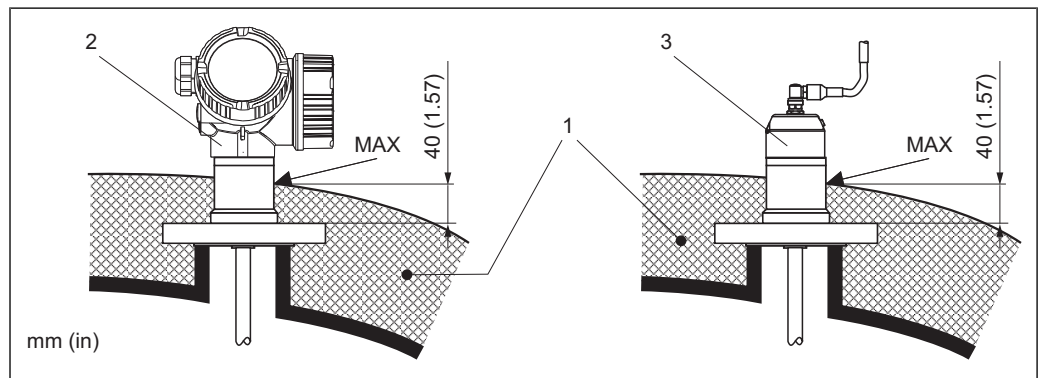

A0014654

7 Process connection with flange - FMP51, FMP52

- 1 Tank insulation
- 2 Compact device
- 3 Sensor remote (feature 600)

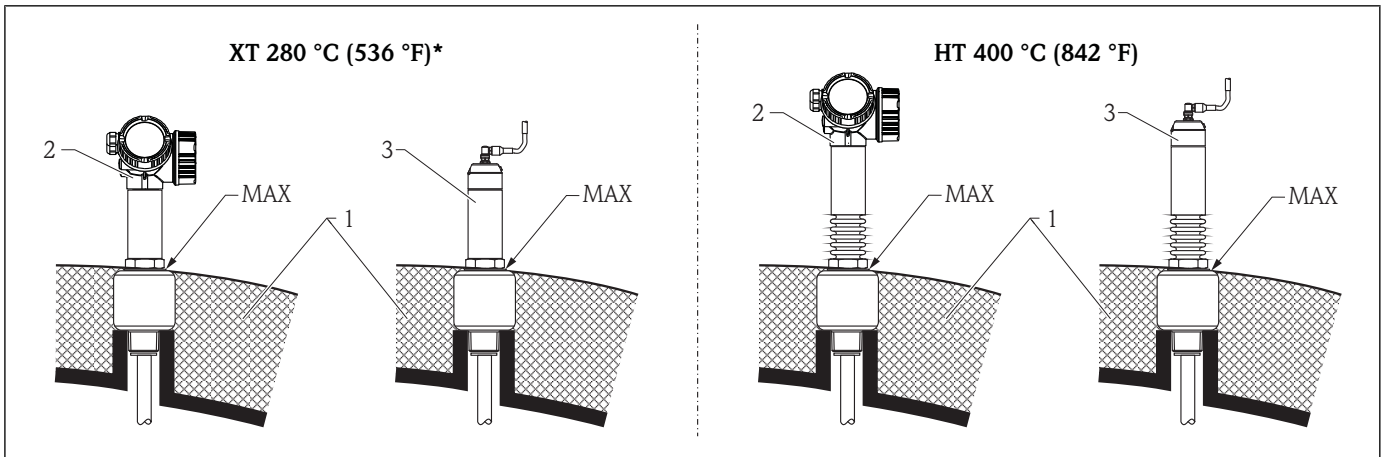

A0014657

8 Process connection with thread – FMP54, sensor version XT and HT

- 1 Tank insulation
- 2 Compact device
- 3 Sensor remote (feature 600)

* The XT version is not recommended for saturated steam above 200 °C (392 °F). Use the HT version instead.

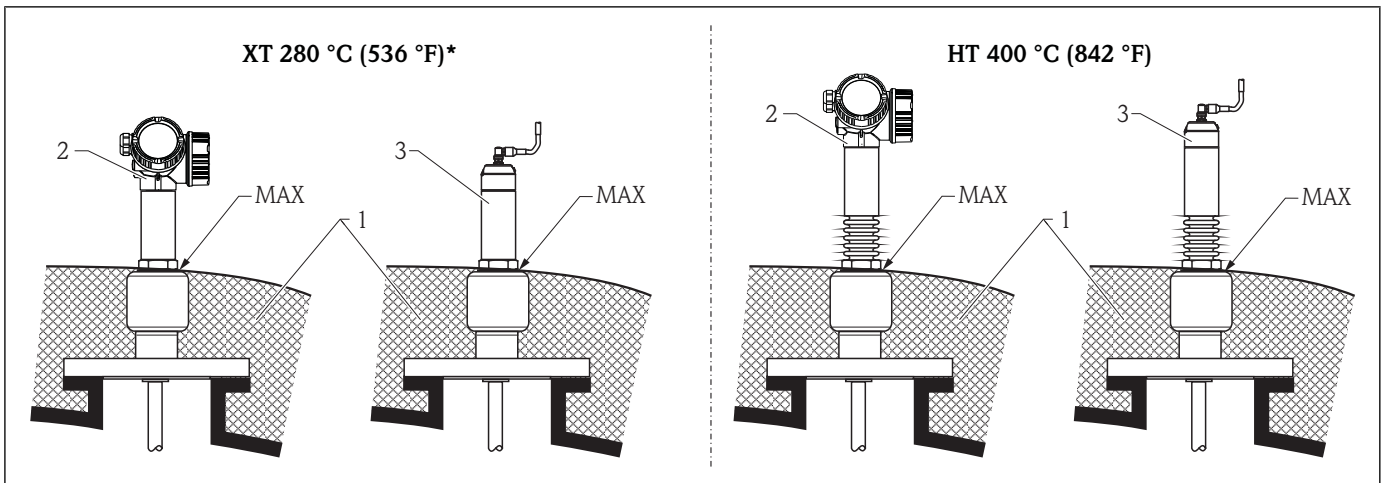

A0014658

9 Process connection with flange – FMP54, sensor version XT and HT

- 1 Tank insulation
- 2 Compact device
- 3 Sensor remote (feature 600)

* The XT version is not recommended for saturated steam above 200 °C (392 °F). Use the HT version instead.

Replacing a displacer system in an existing displacer chamber

FMP51 and FMP54 are a perfect replacement for a conventional displacer system in an existing displacer chamber. Endress+Hauser offers flanges that suit Fischer and Masoneilan displacer chamber for this purpose (special product for FMP51; feature 100, options LNJ, LPJ, LQJ for FMP54). Thanks to menu-guided local operation, commissioning the Levelflex only takes a few minutes. Replacement is also possible when partially filled, and wet calibration is not required.

Your benefits:

- No moving parts, thus zero-maintenance operation.
- Not sensitive to process influences such as temperature, density, turbulence and vibrations.
- The rod probes can be shortened or replaced easily. In this way, the probe can be easily adjusted on site.

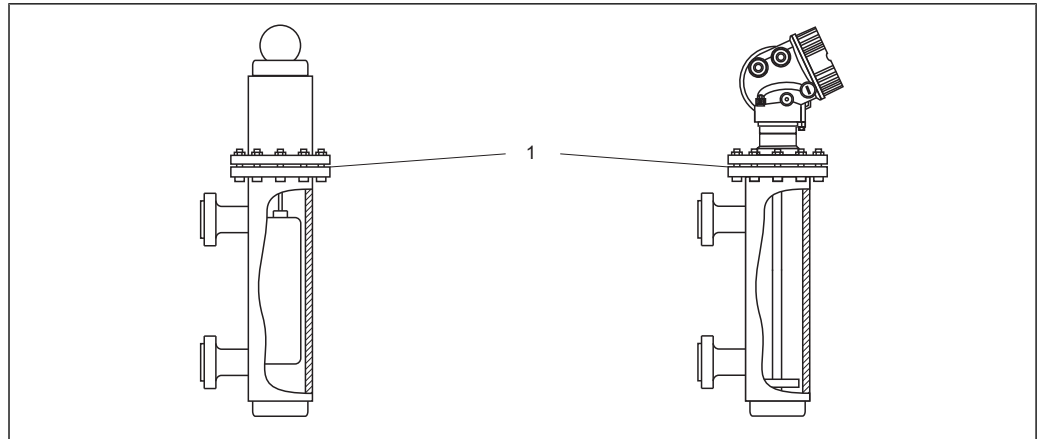

A0014153

1 Flange of the displacer chamber

Planning instructions:

- In normal cases, use a rod probe. When installing into a metallic displacer chamber up to 150 mm, you have all the advantages of a coax probe.
- It must be ensured that the probe does not come into contact with the side wall. Where necessary, use a center washer at the lower end of the probe (feature 610 of the product structure).
- A center washer must be adapted as accurately as possible to the internal diameter of the displacer chamber to also ensure perfect operation in the area of the probe end.

Additional information on interface measurement

- In the case of oil and water the centering disk should be positioned at the lower edge of the lower disposal (water level).
- The pipe may not exhibit any steps in diameter. Use the coax probe where necessary.
- In the case of rod probes, it must be ensured that the probe does not come into contact with the wall. If necessary, use a center washer at the end of the probe.
- A plastic center washer has to be used for interface measurement (feature 610, options OD and OE).

Operating conditions: Environment

Ambient temperature range	Measuring device	-40 to +80 °C (-40 to +176 °F)
	Local display	-20 to +70 °C (-4 to +158 °F), the readability of the display may be impaired at temperatures outside the temperature range.
	Connection cable (for "Probe Design" = "Sensor remote")	85 °C (185 °F)

When operating the device in the open with strong sunlight:

- Mount the device in a shady position.
- Avoid direct sunlight, especially in warmer regions.
- Use a weather protection cover (see accessories).

Ambient temperature limits



The following diagrams take into account only function requirements. There may be further restrictions for certified device versions. Please refer to the separate Safety Instructions (→ 96).

With a temperature (T_p) at the process connection the admissible ambient temperature (T_a) is reduced according to the following diagram (temperature derating):

Temperature derating for FMP51 with threaded connection $G^{3/4}$ or $NPT^{3/4}$

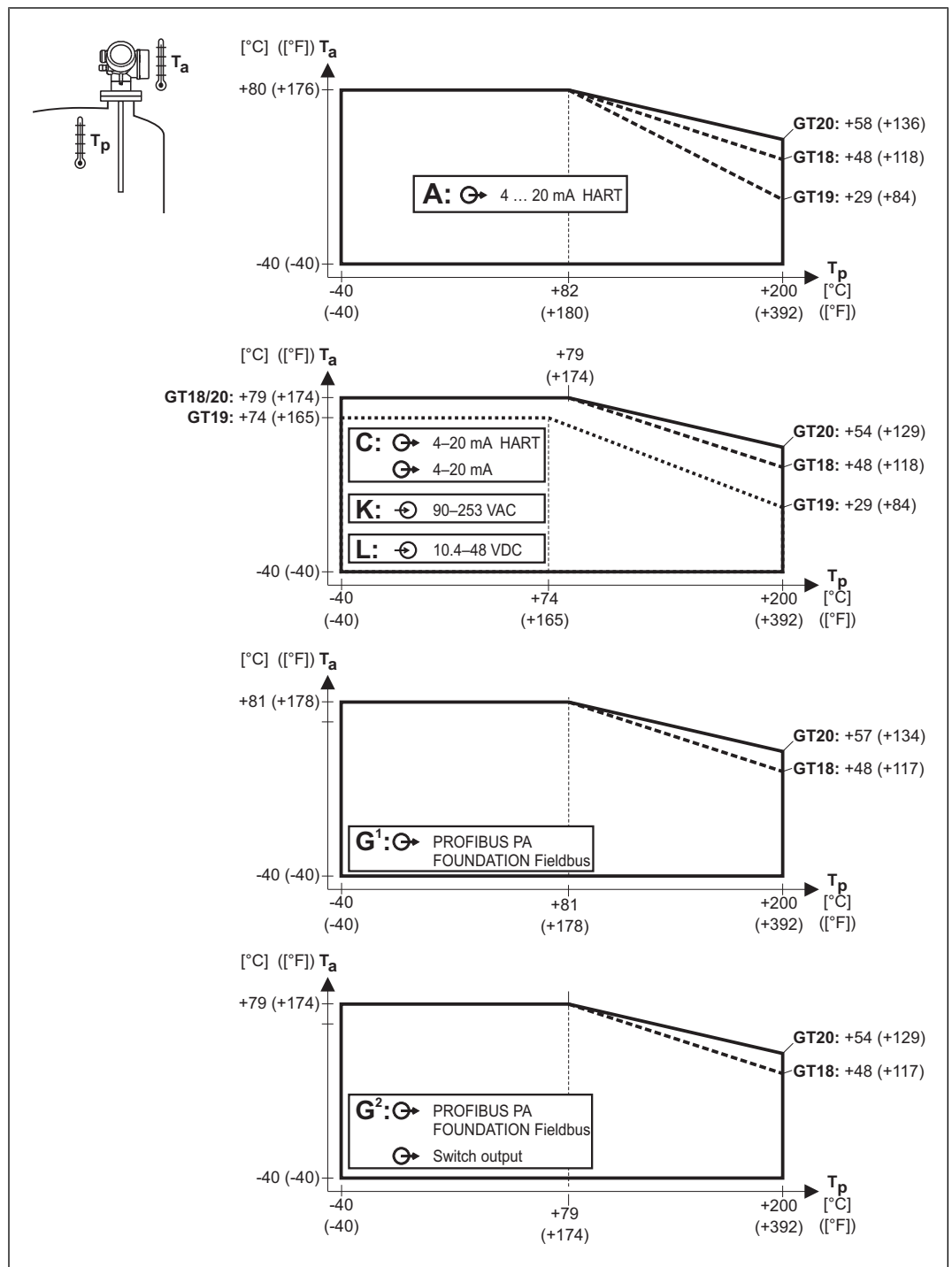

A0013687

GT18 = stainless steel housing
 GT19 = plastic housing
 GT20 = aluminum housing

A = 1 current output
 C = 2 current outputs
 G¹, G² = PROFIBUS PA¹⁾
 K, L = 4-wire

T_a = ambient temperature
 T_p = temperature at the process connection²⁾

- 1) For PROFIBUS PA and FOUNDATION Fieldbus the temperature derating depends on the usage of the switch output. (G¹: switch output not connected; G²: switch output connected).
- 2) For saturated steam applications the process temperature should not exceed 150 °C (302 °F). For higher process temperatures use FMP54.

Temperature derating for FMP51 with threaded connection G1 1/2 or NPT1 1/2

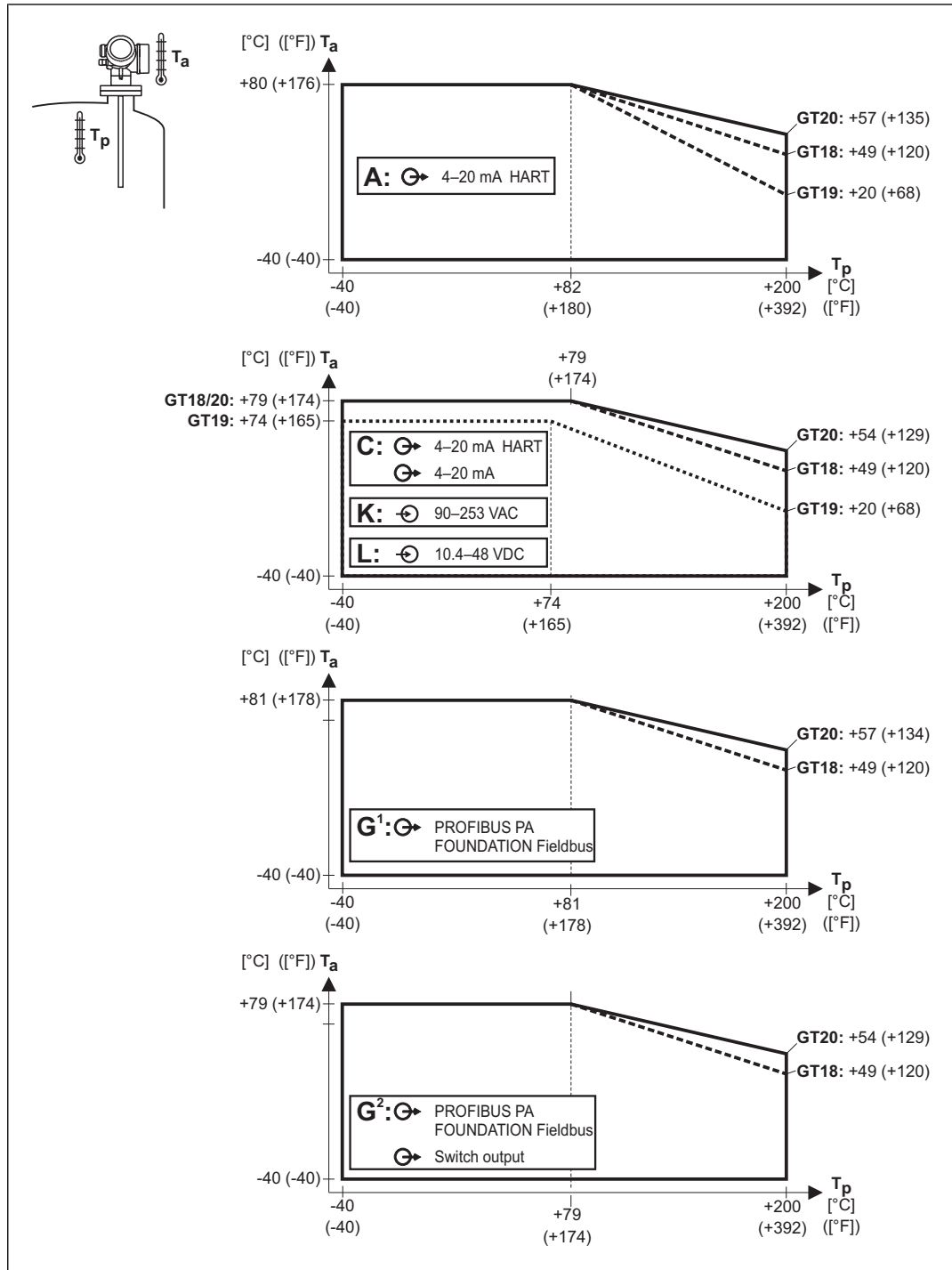

A0014121

GT18 = stainless steel housing
 GT19 = plastic housing
 GT20 = aluminum housing

A = 1 current output
 C = 2 current outputs
 G¹, G² = PROFIBUS PA¹⁾
 K, L = 4-wire

T_a = ambient temperature
 T_p = temperature at the process connection²⁾

- 1) For PROFIBUS PA and FOUNDATION Fieldbus the temperature derating depends on the usage of the switch output. (G¹: switch output not connected; G²: switch output connected).
- 2) For saturated steam applications the process temperature should not exceed 150 °C (302 °F). For higher process temperatures use FMP54.

Temperature derating for FMP51 with flange

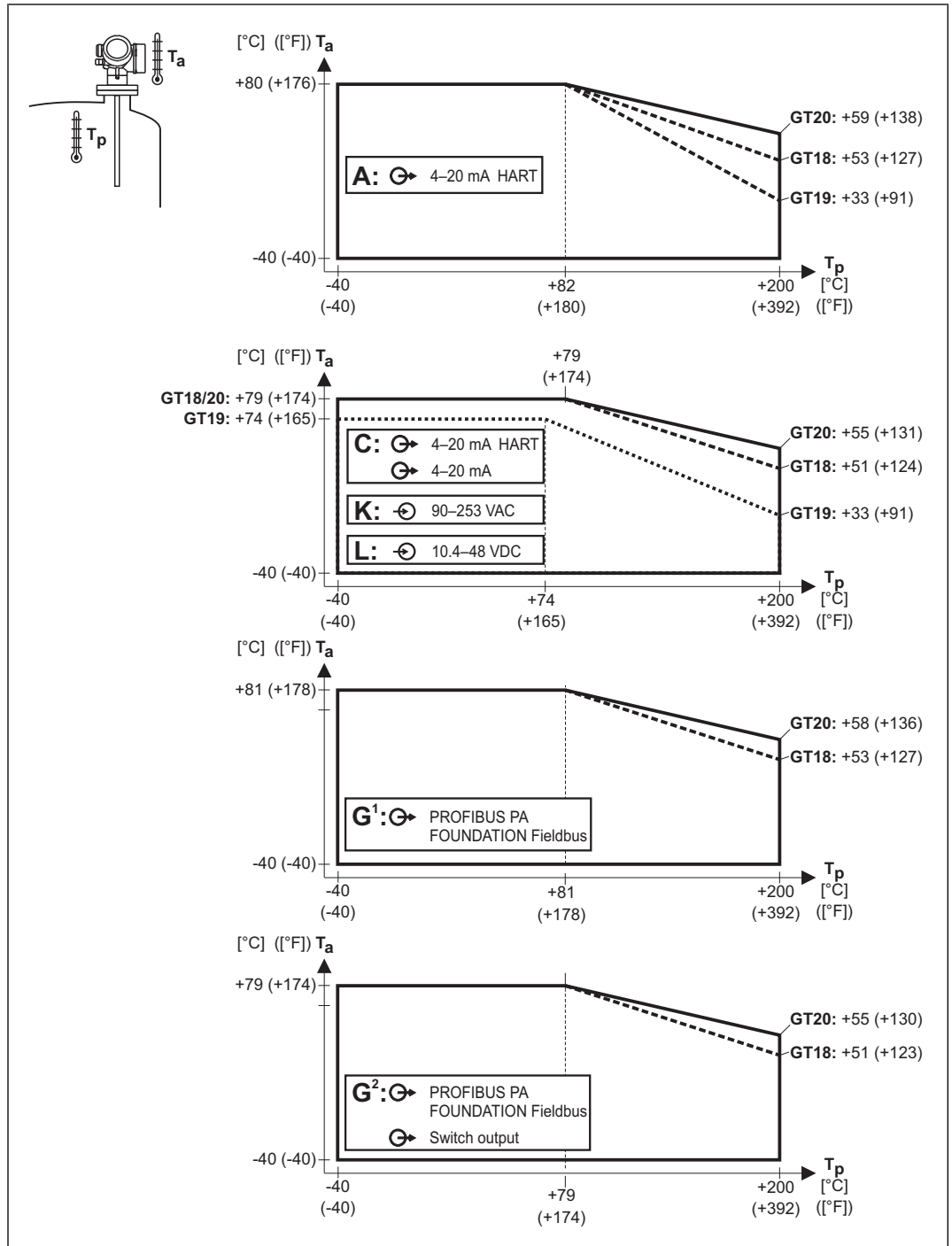

A0013689

GT18 = stainless steel housing
 GT19 = plastic housing
 GT20 = aluminum housing

A = 1 current output
 C = 2 current outputs
 G¹, G² = PROFIBUS PA¹⁾
 K, L = 4-wire

T_a = ambient temperature
 T_p = temperature at the process connection²⁾

- 1) For PROFIBUS PA and FOUNDATION Fieldbus the temperature derating depends on the usage of the switch output. (G¹: switch output not connected; G²: switch output connected).
- 2) For saturated steam applications the process temperature should not exceed 150 $^{\circ}\text{C}$ (302 $^{\circ}\text{F}$). For higher process temperatures use FMP54.

Temperature derating for FMP52

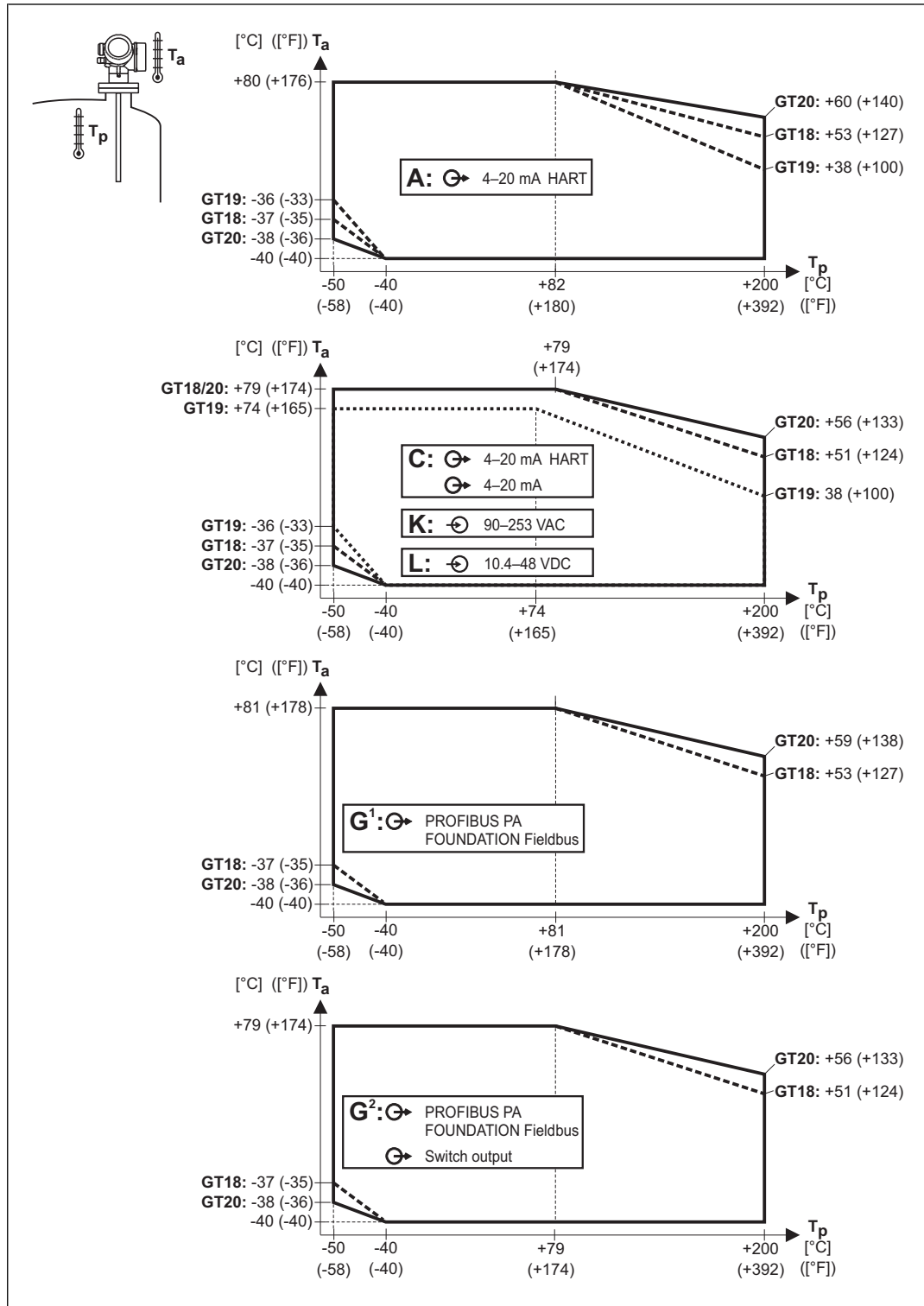

GT18 = stainless steel housing
 GT19 = plastic housing
 GT20 = aluminum housing

A = 1 current output
 C = 2 current outputs
 G¹, G² = PROFIBUS PA¹⁾
 K, L = 4-wire

T_a = ambient temperature
 T_p = temperature at the process connection

1) For PROFIBUS PA and FOUNDATION Fieldbus the temperature derating depends on the usage of the switch output. (G¹: switch output not connected; G²: switch output connected).

Temperature derating for FMP54 - version XT up to +280 °C (+536 °F)

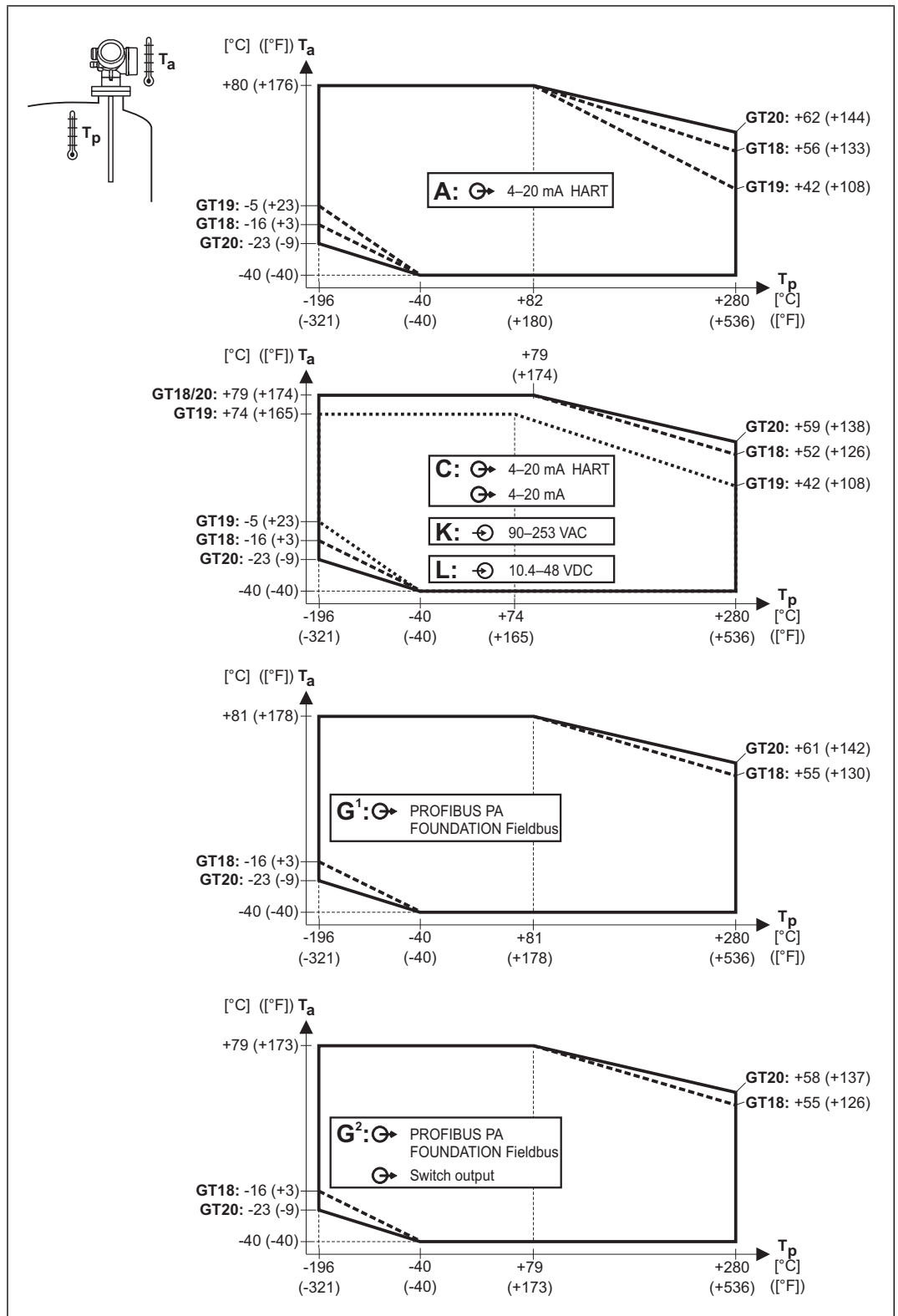

A0013631

GT18 = stainless steel housing
 GT19 = plastic housing
 GT20 = aluminum housing

A = 1 current output
 C = 2 current outputs
 G¹, G² = PROFIBUS PA¹⁾
 K, L = 4-wire

T_a = ambient temperature
 T_p = temperature at the process connection²⁾

- 1) For PROFIBUS PA and FOUNDATION Fieldbus the temperature derating depends on the usage of the switch output. (G¹: switch output not connected; G²: switch output connected).
- 2) For saturated steam applications the process temperature should not exceed 200 °C (392 °F). For higher process temperatures use the HT version.

Temperature derating for FMP54 - version HT up to +450 °C (+842 °F)

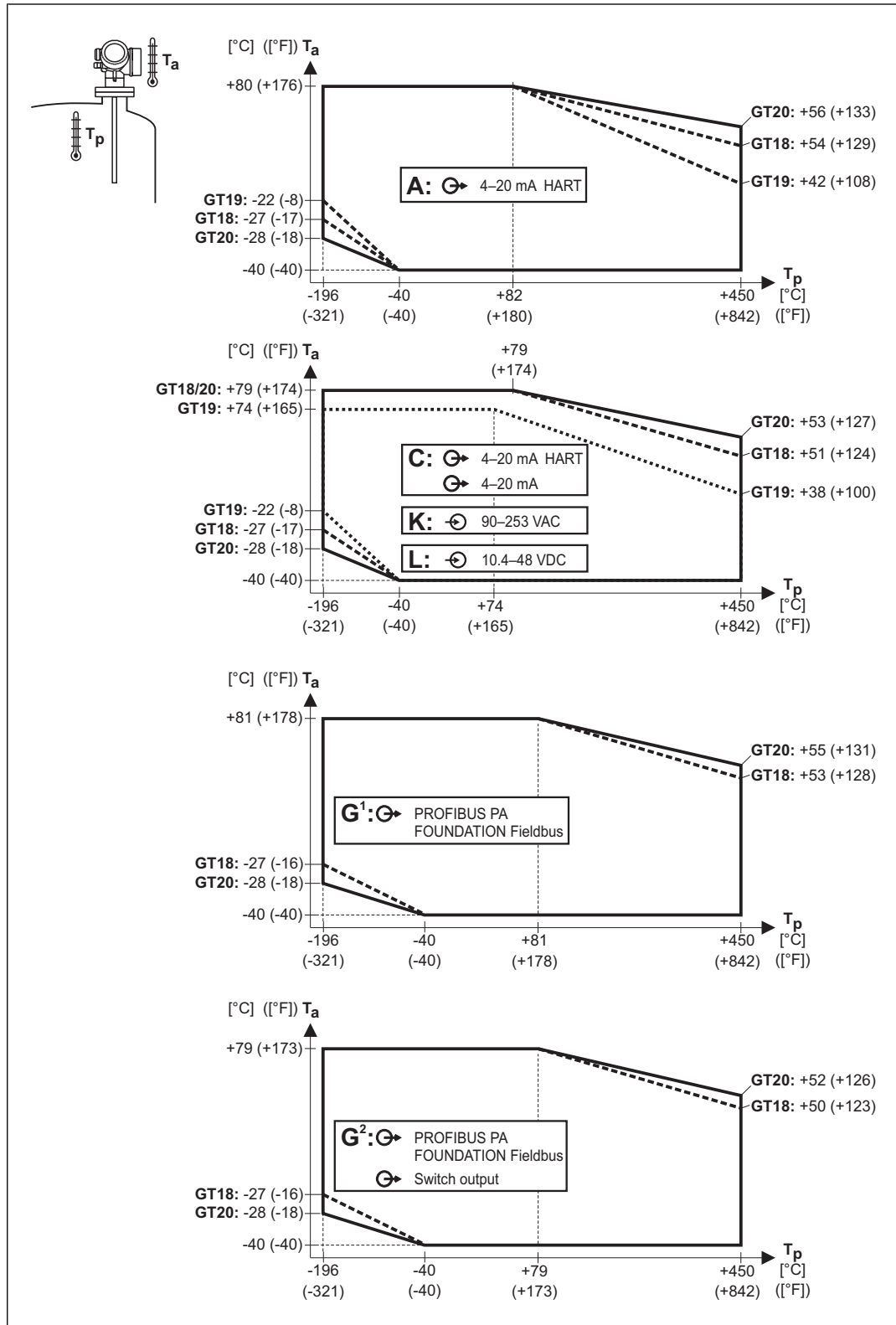

A0013632

GT18 = stainless steel housing
 GT19 = plastic housing
 GT20 = aluminum housing

A = 1 current output
 C = 2 current outputs
 G¹, G² = PROFIBUS PA¹⁾
 K, L = 4-wire

T_a = ambient temperature
 T_p = temperature at the process connection

1) For PROFIBUS PA and FOUNDATION Fieldbus the temperature derating depends on the usage of the switch output. (G¹: switch output not connected; G²: switch output connected).

Storage temperature	-40 to +80 °C (-40 to +176 °F)
Climate class	DIN EN 60068-2-38 (test Z/AD)
Geometric height	Up to 2000 m (6600 ft) above MSL. Can be expanded to 3000 m (9800 ft) above MSL by application of an overvoltage protection, e.g. HAW562 or HAW569.
Degree of protection	<ul style="list-style-type: none"> ■ With closed housing tested according to: <ul style="list-style-type: none"> - IP68, NEMA6P (24 h at 1.83 m under water surface) - For plastic housing with transparent cover (display module): IP68 (24 h at 1.00 m under water surface) ⁴⁾ - IP66, NEMA4X ■ With open housing: IP20, NEMA1 (also ingress protection of the display) <p> Degree of protection IP68 NEMA6P applies for M12 PROFIBUS PA plugs only when the PROFIBUS cable is plugged in and is also rated IP68 NEMA6P.</p>
Vibration resistance	DIN EN 60068-2-64 / IEC 68-2-64: 20 to 2000 Hz, 1 (m/s ²)/Hz
Cleaning the probe	Depending on the application, contamination or buildup can accumulate on the probe. A thin, even layer only influences measurement slightly. Thick layers can dampen the signal and then reduce the measuring range. Severe, uneven buildup, adhesion e.g. through crystallization, can lead to incorrect measurement. In this case, we recommend that you use a non-contact measuring principle, or check the probe regularly for soiling.
Electromagnetic compatibility (EMC)	<p>Electromagnetic compatibility to all relevant requirements of the EN 61326-series and NAMUR recommendation EMC (NE21). For details see declaration of conformity. ⁵⁾ If only the analogue signal is used, unshielded interconnection lines are sufficient for the installation. In case of using the digital signal (HART/PA/FF) use shielded interconnection lines.</p> <p>Use a shielded cable when working with a digital communications signal.</p> <p>Max. fluctuations during EMC- tests: < 0.5 % of the span.</p> <p>When installing the probes in metal and concrete tanks and when using a coax probe:</p> <ul style="list-style-type: none"> ■ Interference emission to EN 61326 - x series, electrical equipment Class B. ■ Interference immunity to EN 61326 - x series, requirements for industrial areas and NAMUR Recommendation NE 21 (EMC) <p>The measured value can be affected by strong electromagnetic fields when installing rod and rope probes without a shielding/metallic wall, e.g. in plastic and wooden silos.</p> <ul style="list-style-type: none"> ■ Interference emission to EN 61326 - x series, electrical equipment Class A. ■ Interference Immunity: the measured value can be affected by strong electromagnetic fields.

Operating conditions: Process

Process temperature range The maximum permitted temperature at the process connection is determined by the O-ring version ordered:

Device	O-ring material	Process temperature	Approval
FMP51	FKM (Viton GLT)	-30 to +150 °C (-22 to +302 °F)	
	EPDM (70C4 pW FKN or E7515)	-40 to +120 °C (-40 to +248 °F)	
	FFKM (Kalrez 6375)	-20 to +200 °C (-4 to +392 °F) ¹⁾	
FMP52	—	-50 to +200 °C (-58 to +392 °F); completely coated	FDA, 3-A, EHEDG, USP Cl. VI ²⁾

4) This restriction is valid if the following options of the product structure have been selected at the same time: 030("Display, Operation")= C("SD02") or E("SD03"); 040("Housing") = A("GT19").
5) Can be downloaded from www.endress.com.

Device	O-ring material	Process temperature	Approval
FMP54	Graphite	Version XT: -196 to +280 °C (-321 to +536 °F) ³⁾	
		Version HT: -196 to +450 °C (-321 to +842 °F)	

- 1) Not recommended for saturated steam above 150 °C (302 °F). Use FMP54 instead.
- 2) Plastic parts in contact with process have been tested according to USP <88> Class VI-70°C.
- 3) Not recommended for saturated steam above 200 °C (392 °F). Use the HT version instead.



With uncoated probes, the medium temperature can be higher.

However, when using rope probes the stability of the probe rope is reduced by structural changes at temperatures over 350 °C (662 °F).

Process pressure limits

Device	Process pressure
FMP51	-1 to 40 bar (-14.5 to 580 psi)
FMP52	-1 to 40 bar (-14.5 to 580 psi)
FMP54	-1 to 400 bar (-14.5 to 5800 psi)

FMP54 - process pressure depending on the process temperature

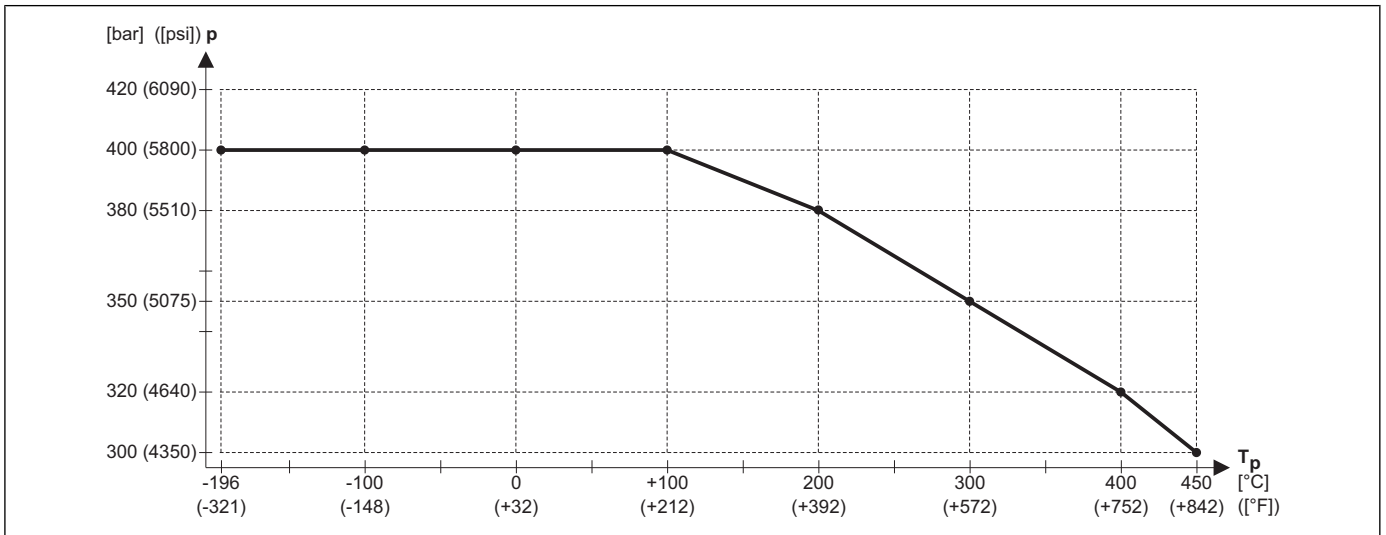

A0014005

p = process pressure

T_p = process temperature



This range may be reduced by the selected process connection. The pressure rating (PN) specified on the flanges refers to a reference temperature of 20 °C, for ASME flanges 100 °F. Pay attention to pressure-temperature dependencies.

Please refer to the following standards for the pressure values permitted for higher temperatures:

- EN 1092-1: 2001 Tab. 18
With regard to their temperature stability properties, the materials 1.4435 and 1.4404 are grouped under 13E0 in EN 1092-1 Tab. 18. The chemical composition of the two materials can be identical.
- ASME B 16.5a - 1998 Tab. 2-2.2 F316
- ASME B 16.5a - 1998 Tab. 2.3.8 N10276
- JIS B 2220

Materials in contact with process

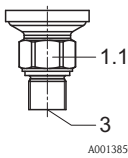
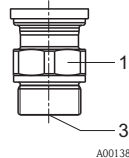
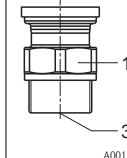
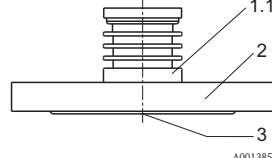
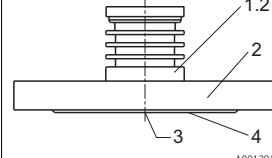

- Endress+Hauser supplies DIN/EN flanges and threaded process connections made of stainless steel according to AISI 316L (DIN/EN material number 1.4404 or 1.4435). With regard to their temperature stability properties, the materials 1.4404 and 1.4435 are grouped under 13E0 in EN 1092-1 Tab. 18. The chemical composition of the two materials can be identical.
- Further material specifications (→ 69)

Levelflex FMP51						
Threaded connection			Flange		No.	Material
<i>G^{3/4}, NPT^{3/4}</i>	<i>G1 1/2</i>	<i>NPT1 1/2</i>	<i>DN40...DN200</i>	<i>DN40...DN100</i>		
					1.1	316L (1.4404)
					1.2	Alloy C22 (2.4602)
					2	ASME: 316/316L EN: 316L (1.4404) JIS: 316L (1.4435)
					3	Ceramic Al ₂ O ₃ 99.7 %
					4	Cladding: Alloy C22 (2.4602)

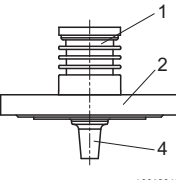
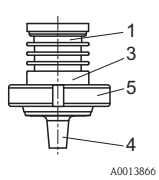
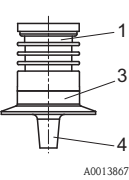
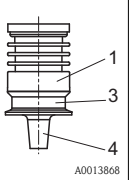
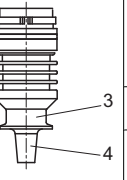
Levelflex FMP52							
Flange	Dairy coupling	Tri-Clamp			No.	Material	Approval
<i>EN/ASME/JIS</i>	<i>DN50 (DIN 11851)</i>	<i>3"</i>	<i>2"</i>	<i>1 1/2"</i>			
					1	304 (1.4301)	
					2	ASME: 316/316L EN: 316L (1.4404) JIS: 316L (1.4435)	
					3	316L (1.4404)	
					4	Coating 2 mm (0.08 in): PTFE (Dyneon TFM1600)	USP Cl. VI ¹⁾
					5	304L (1.4307)	

1) Plastic parts in contact with process have been tested according to USP <88> Class VI-70°C.

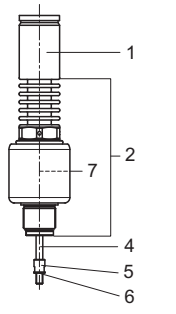
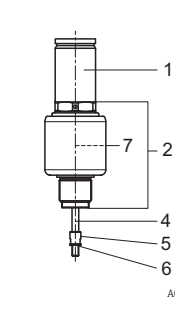
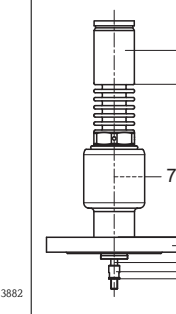
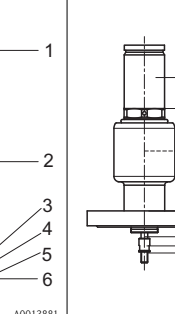
Levelflex FMP54					
Threaded connection <i>G1 1/2, NPT1 1/2</i>		Flange		No.	Material
<i>Variante HT</i>	<i>Variante XT</i>	<i>Variante HT</i>	<i>Variante XT</i>		
				1	304 (1.4301)
				2	316L (1.4404)
				3	ASME: 316/316L EN: 316L (1.4404) JIS: 316L (1.4435)
				4	Alloy C22 (2.4602)
				5	316L (1.4404)
				6	Nordlock washer: 1.4547
				7	Ceramic Al ₂ O ₃ 99.7 %, pure graphite

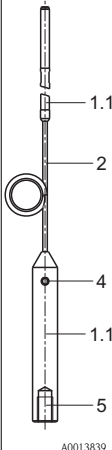
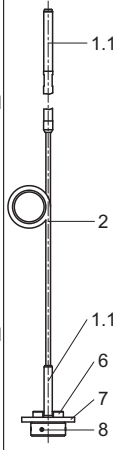
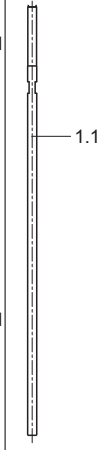
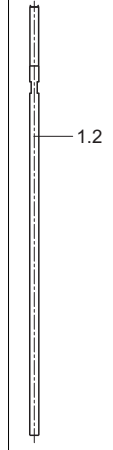
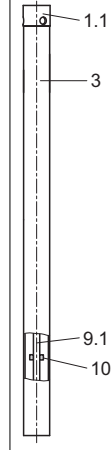
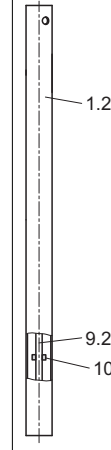
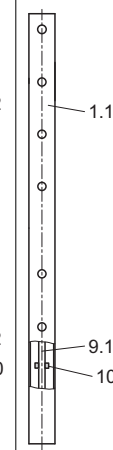
Levelflex FMP51							No.	Material
Rope probe		Rod probe		Coax probe				
Ø 4 mm (1/6")	Ø 4 mm (1/6") with centering disk	Ø 8 mm (1/3")	Ø 12.7 mm (1/2") AlloyC	Thread G3/4	Thread G1-1/2 AlloyC	Thread G1-1/2 316L		
 A0013839	 A0013855	 A0013838	 A0013912	 A0013856	 A0013911	 A0017244	1.1	316L (1.4404)
							1.2	Alloy C22 (2.4602)
							1.3	316L (1.4435)
							2	316 (1.4401)
							3	316L (1.4435)
							4	Set screw: A4-70
							5	Screw for tightening: A2-70
							6	Socket cap screw: A4-80
							7	Disk: 316L (1.4404)
							8	Set screw: A4-70
9.1	Rod: 316L (1.4404)							
9.2	Alloy C22 (2.4602)							
10	Spacer: PFA							

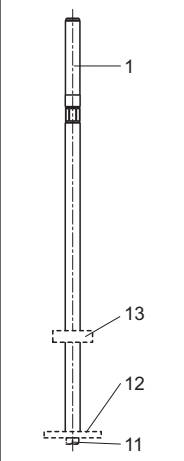
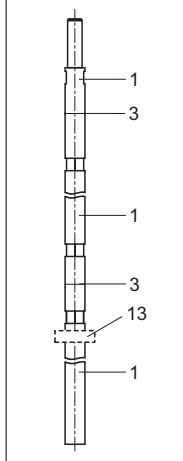
Levelflex FMP51			
Rod probe		No.	Material
Ø 12 mm (1/2") 316L	Ø 16 mm (2/3") divisible		
 A0013860	 A0013861	1	316L (1.4404)
		3	Connecting bolt: Alloy C22 (2.4602) Nordlock washer: 1.4547
		11	Hexagon head screw: A4-70 Nordlock washer: 1.4547
		12	Centering disk, PEEK Centering disk, 316L (1.4404)
		13	Centering disk, PFA

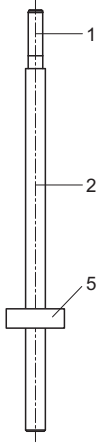
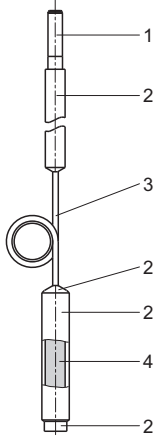
Levelflex FMP52						
Rod probe Ø 16 mm (2/3") coated		Rope probe Ø 4 mm (1/6") coated		No.	Material	
 <p style="text-align: center;">A0013870</p>	 <p style="text-align: center;">A0013871</p>	1	316L (1.4404)			
		2	Coating 2 mm (0.08 in): PFA (Daikin PFA AP230)			
		3	Rope: 316L (1.4404)			
			Coating 0.75mm (0.03 in): PFA (Daikin PFA AP230)			
		4	Core: 316L (1.4435)			
	5		PFA (Daikin PFA AP230), centering disk			

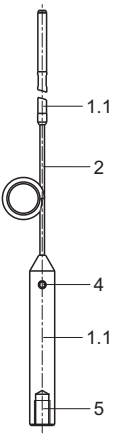
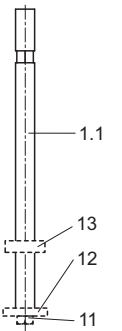
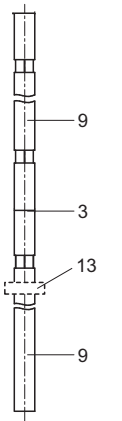
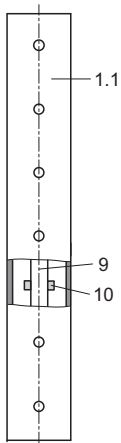
Levelflex FMP54								
Rope probe Ø 4 mm (1/6")		Rod probe Ø 16 mm (2/3") with centering disk		Coax probe	No.	Material		
Ø 4 mm (1/6") with centering disk	Ø 16 mm (2/3") with centering disk	Ø 16 mm (2/3") with centering disk	Ø 16 mm (2/3") divisible					
 <p style="text-align: center;">A0013839</p>	 <p style="text-align: center;">A0013885</p>	 <p style="text-align: center;">A0013886</p>	 <p style="text-align: center;">A0013864</p>	1.1	316L (1.4404)			
				2	316 (1.4401)			
				3	Connecting bolt: Alloy C22 (2.4602)			
					Nordlock washer: 1.4547			
				4	Set screw: A4-70			
				5	Screw for tightening: A2-70			
				6	Socket cap screw: A4-80			
				7	Disk: 316L (1.4404)			
				8	Set screw: A4-70			
				9	Stab: 316L (1.4404)			
				10	Spacer: ceramic Al ₂ O ₃ 99.7 %			
				11	Hexagon head screw: A4-70			
					Nordlock washer: 1.4547			
12	Centering disk, PEEK							
	Centering disk, 316L (1.4404)							
13	Centering disk, PFA							

Dielectric constant (DC)

- Coax probes: DC (ϵ_r) ≥ 1.4
- Rod and rope probe: DC (ϵ_r) ≥ 1.6 (when installing in pipes DN ≤ 150 mm (6 in): DC (ϵ_r) ≥ 1.4)

Extension of the rope probes through temperature

Elongation through temperature increase from 30 °C (86 °F) to 150 °C (302 °F): 2 mm / m rope length

Mechanical construction

Design, dimensions

Dimensions of the electronics housing

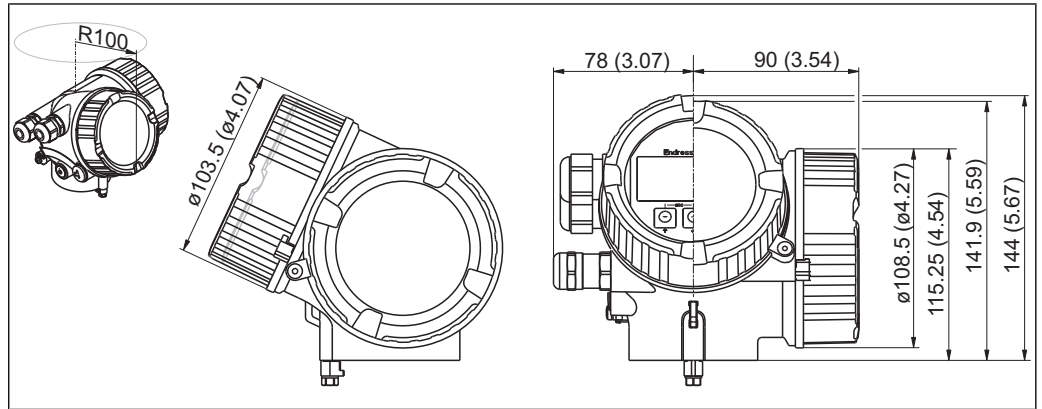

A0015132

10 Housing GT18 (316L); Dimensions in mm (in)

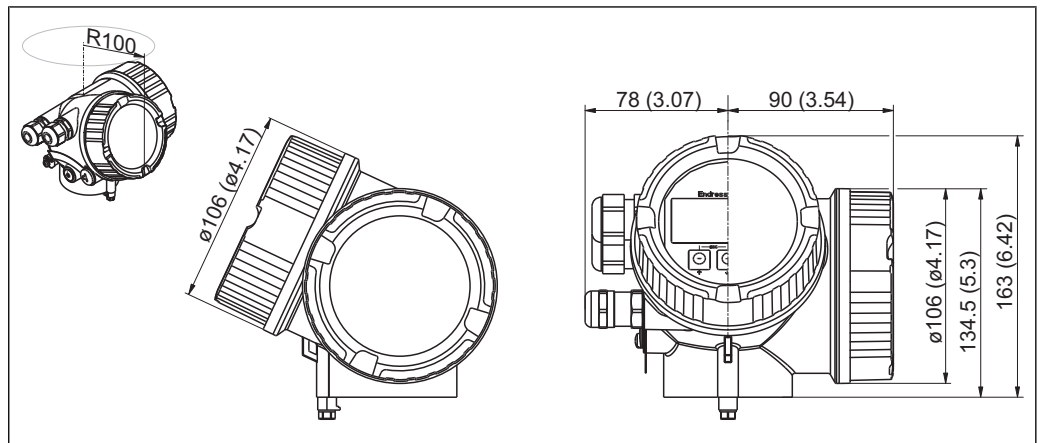

A0015133

11 Housing GT19 (Plastics PBT); Dimensions in mm (in)

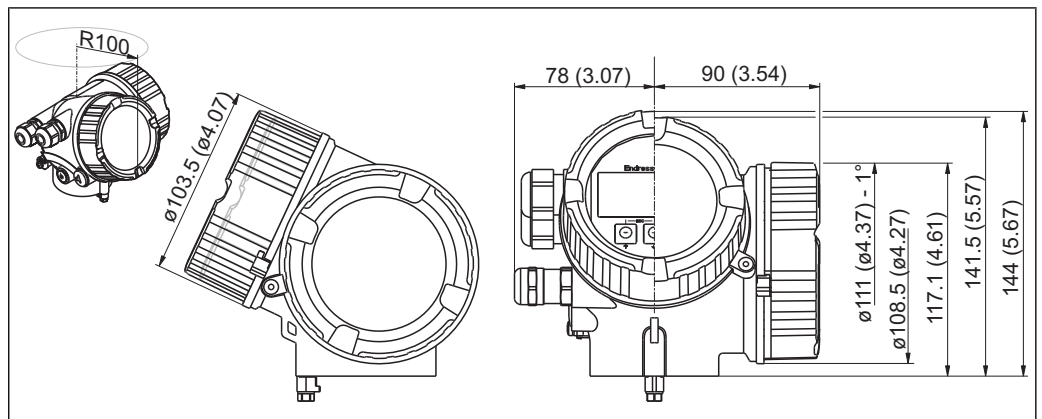

A0015134

12 Housing GT20 (Alu coated); Dimensions in mm (in)

Dimensions of the mounting bracket

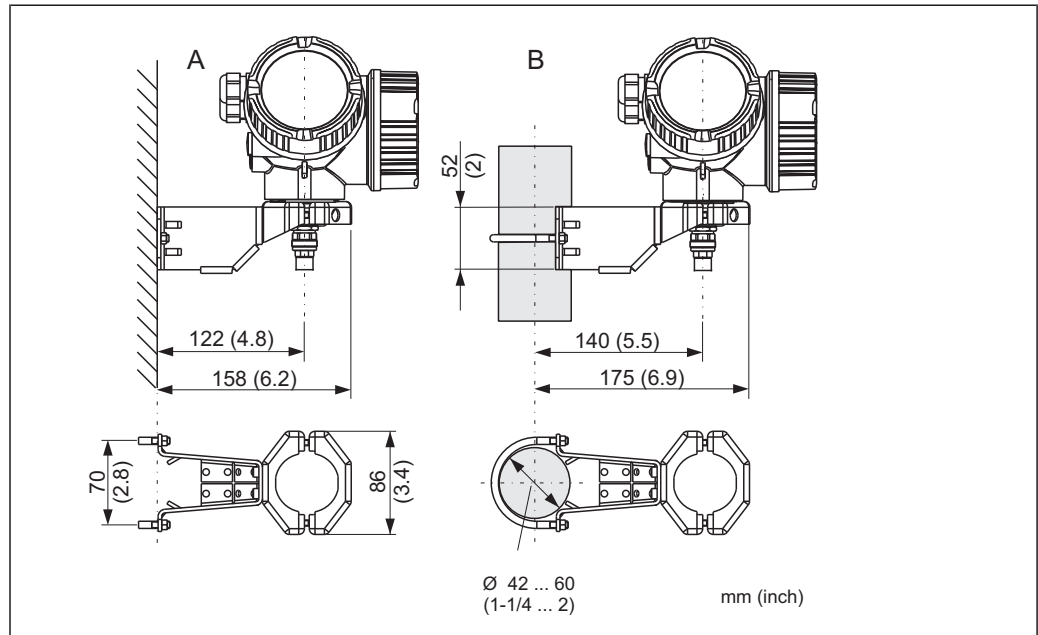

A0014793

13 Mounting bracket for the electronics housing

- A Wall mounting
- B Pipe mounting

i For the "Sensor remote" device version (see feature 060 of the product structure), the mounting bracket is part of the delivery. If required, it can also be ordered as an accessory (order code 71102216).

FMP51: Dimensions of process connection (G $\frac{3}{4}$,NPT $\frac{3}{4}$) and probe

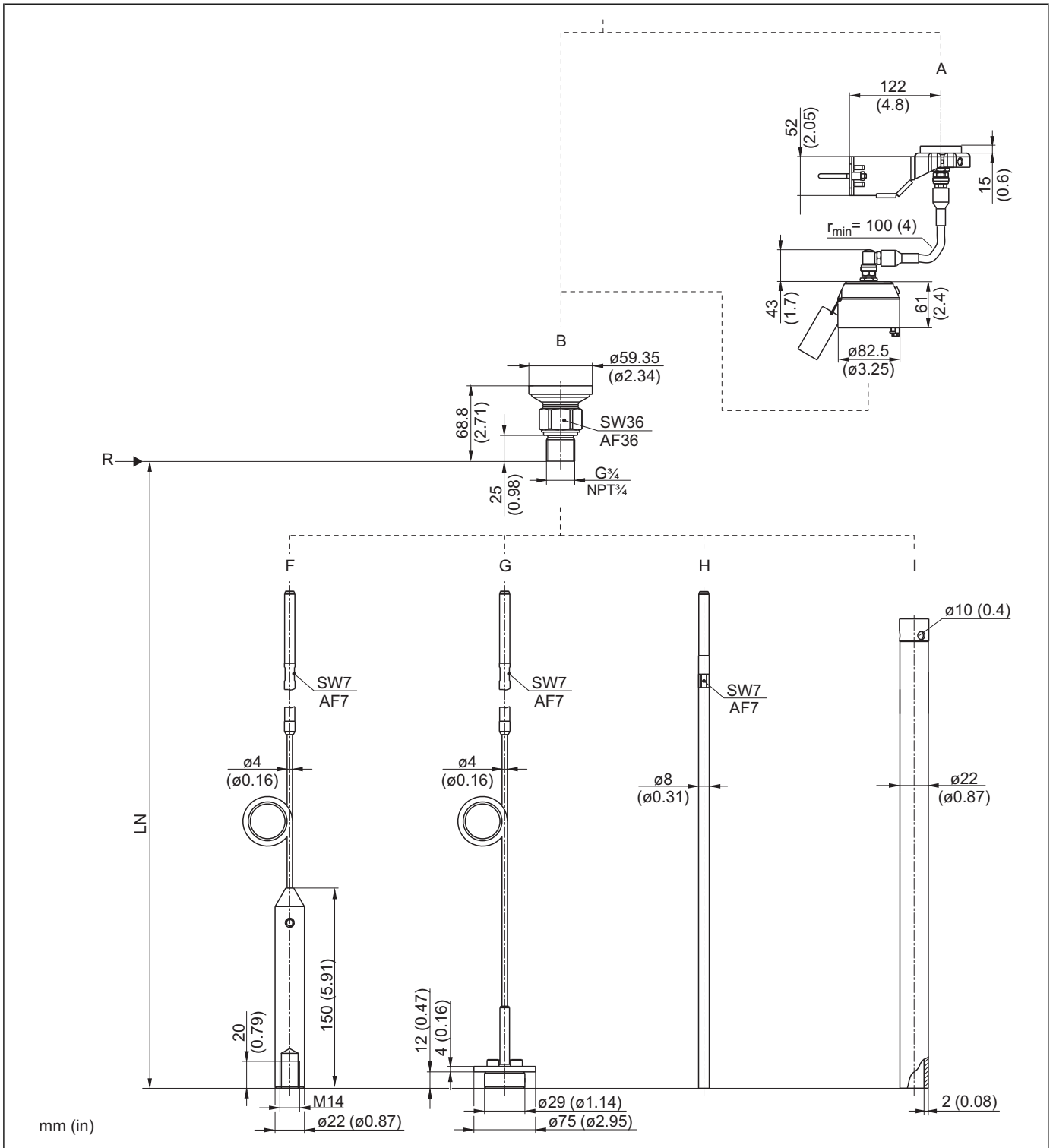

- A Mounting bracket for probe design "Sensor remote" (Feature 600)
- B Thread ISO G $\frac{3}{4}$ or ANSI MNPT $\frac{3}{4}$ (Feature 100)
- F Rope probe 4mm or 1/6" (Feature 060)
- G Rope probe 4 mm or 1/6"; centering disk optional (Features 060 and 610)
- H Rod probe 8mm or 1/3" (Feature 060)
- I Coax probe (Feature 060)
- LN Length of probe
- R Reference point of the measurement

O Coax probe; 316L (Feature 060)
LN Length of probe
R Reference point of the measurement

	P	Q	S
PEEK	7 mm (0.28 in)	Ø95 mm (3.74 in)	
PFA	10 mm (0.39 in)	37 mm (1.46 in)	110 mm (4.33 in)
316L	4 mm (0.16 in)	Ø45 mm (1.77 in)	
		Ø75 mm (2.95 in)	

FMP52: Dimensions of process connection and probe

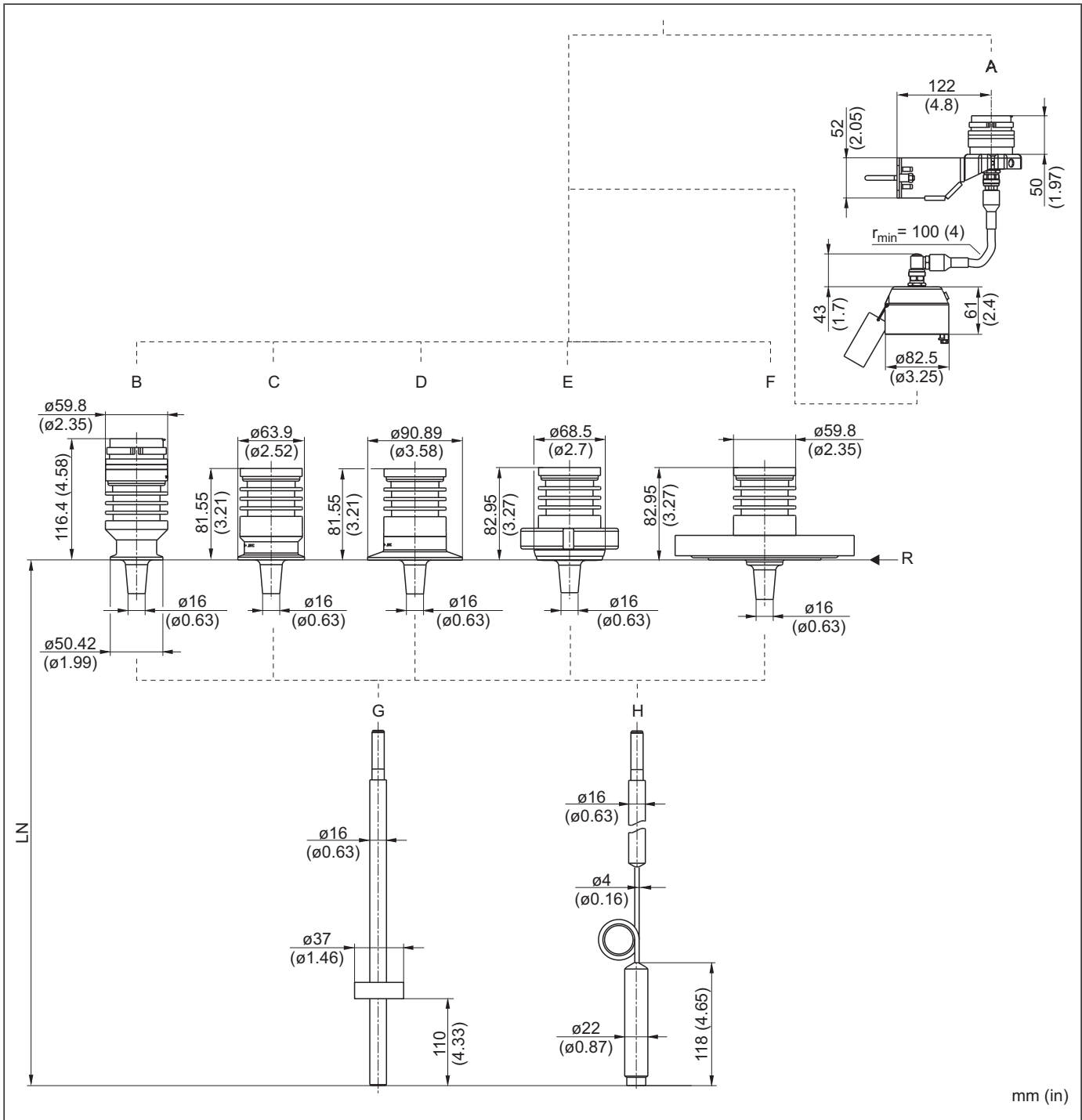

A0012757

- A Mounting bracket for probe design "Sensor remote" (Feature 600)
- B Tri-Clamp 1-1/2" (Feature 100)
- C Tri-Clamp 2" (Feature 100)
- D Tri-Clamp 3" (Feature 100)
- E DIN 11851 (Dairy coupling) DN50 (Feature 100)
- F Flange ANSI B16.5, EN1092-1, JIS B2220 (Feature 100)
- G Rod probe 16mm or 0.63 in, PFA>316L (Feature 060)
- H Rope probe 4mm or 1/6", PFA>316 (Feature 060)
- LN Length of probe
- R Reference point of the measurement

FMP54: Dimensions of process connection and probe

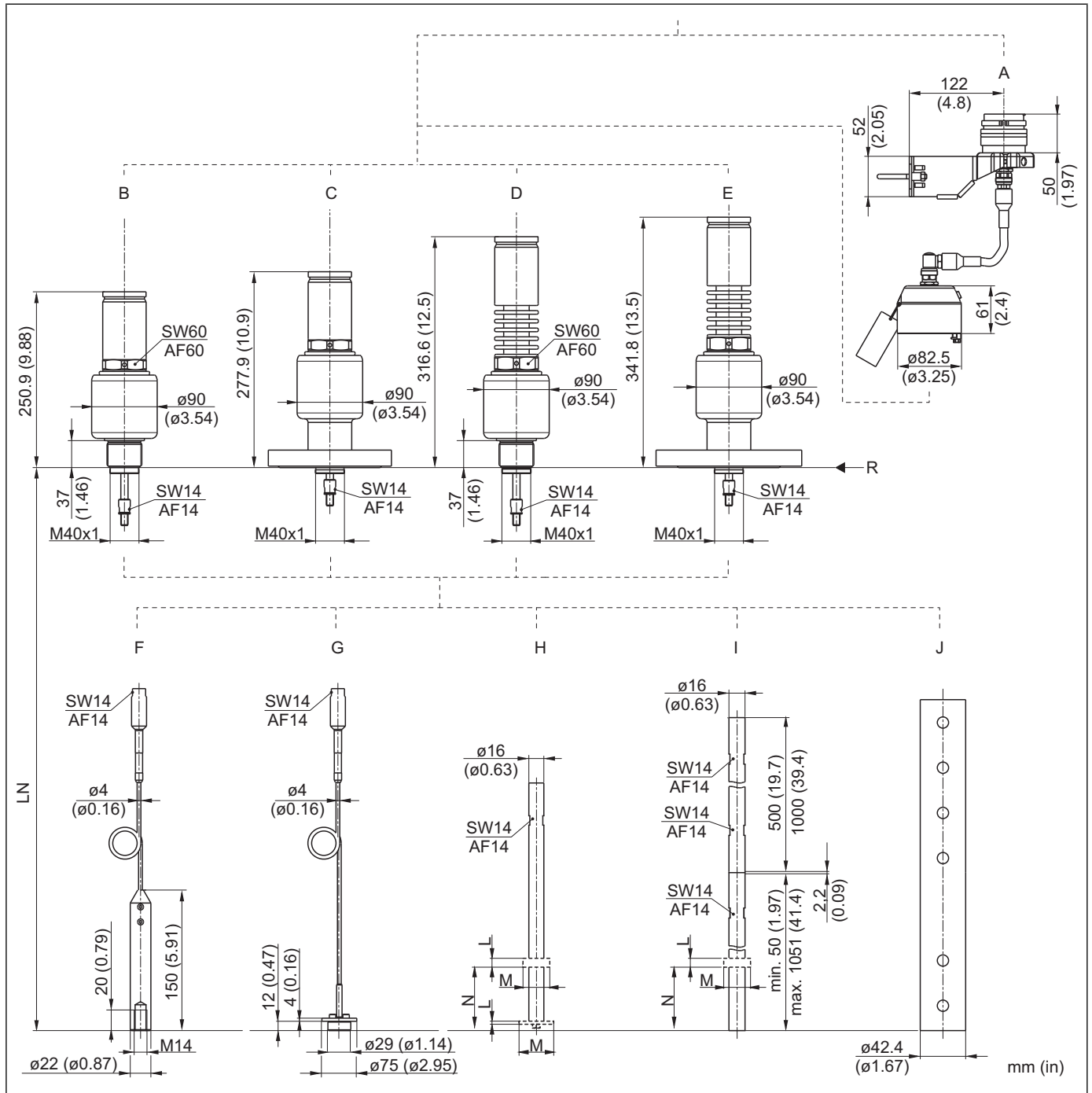

A0012778

- A Mounting bracket for probe design "Sensor remote" (Feature 600)
- B Thread ISO228 G1-1/2 or ANSI MNPT1-1/2; XT 280 °C (Features 100 and 090)
- C Flange ANSI B16.5, EN1092-1, JIS B2220; XT 280 °C (Features 100 and 090)
- D Thread ISO228 G1-1/2 or ANSI MNPT1-1/2; HT 450 °C (Features 100 and 090)
- E Flange ANSI B16.5, EN1092-1, JIS B2220; HT 450 °C (Features 100 and 090)
- F Rope probe 4mm or 1/6" (Feature 060)
- G Rope probe 4mm (1/6"), centering disk optional (Features 060 and 610)
- H Rod probe 16mm or 0.63in; centering disk optional, see table below (Features 060 and 610)
- I Rod probe 16mm or 0.63in; 20" or 40" divisible; centering disk optional, see table below (Feature 060 and 610)

J Coax probe (Feature 060)
 LN Length of probe
 R Reference point of the measurement

	L	M	N
PEEK	7 mm (0.28 in)	∅95 mm (3.74 in)	-
PFA	10 mm (3.94 in)	37 mm (1.46 in)	110 mm (4.33 in)
316L	4 mm (0.16 in)	∅45 mm (1.77 in)	
		∅75 mm (2.95 in)	-

Surface roughness of AlloyC-coated flanges

Ra = 3.2 µm; lower surface roughness levels are available on request.

DThis value is valid for flanges with "AlloyC>316/316L"; see product structure, feature 100 "Process connection" . For other flanges the surface roughness matches the corresponding flange standard.

Tolerance of probe length

Rod probes				
Over [m (ft)]	—	1 (3,3)	3 (9,8)	6 (20)
Up to [m (ft)]	1 (3,3)	3 (9,8)	6 (20)	—
Admissible tolerance [mm (in)]	-5 (-0,2)	-10 (-0,39)	-20 (-0,79)	-30 (-1,18)

Rope probes				
Over [m (ft)]	—	1 (3,3)	3 (9,8)	6 (20)
Up to [m (ft)]	1 (3,3)	3 (9,8)	6 (20)	—
Admissible tolerance [mm (in)]	-10 (-0,39)	-20 (-0,79)	-30 (-1,18)	-40 (-1,57)

Weight

Housing

Part	Weight
Housing GT18 - stainless steel	approx. 4.5 kg
Housing GT19 - plastic	approx. 1.2 kg
Housing GT20 - aluminium	approx. 1.9 kg

FMP51 with threaded connection G^{3/4} or NPT^{3/4}

Part	Weight	Part	Weight
Sensor	approx. 0.8 kg	Rod probe 8 mm	approx. 0.4 kg/m probe length
Rope probe 4 mm	approx. 0.,1 kg/m probe length	Coax probe	approx. 1.2 kg/m probe length

FMP51 with threaded connection G1 1/2/NPT1 1/2 or flange

Part	Weight	Part	Weight
Sensor	approx. 1.2 kg + weight of flange	Rod probe 16 mm	approx. 1.1 kg/m probe length
Rope probe 4 mm	approx. 0.1 kg/m probe length	Coax probe	approx. 3.0 kg/m probe length
Rod probe 12 mm	approx. 0.9 kg/m probe length		

FMP52

Part	Weight	Part	Weight
Sensor	approx. 1.2 kg + weight of flange	Rope probe 4 mm	approx. 0.5 kg/m probe length
		Rod probe 16 mm	approx. 1.1 kg/m probe length

FMP54

Part	Weight	Part	Weight
Sensor - version XT	approx. 6.7 kg + weight of flange	Rope probe 4 mm	approx. 0.1 kg/m probe length
Sensor - version HT	approx. 7.7 kg + weight of flange	Rod probe 16 mm	approx. 1.6 kg/m probe length
		Coax probe	approx. 3.5 kg/m probe length

Materials



Further material specifications

- Materials in contact with process (→ 58)
- Ordering information (→ 79)
- Accessories materials (→ 89)

Housing

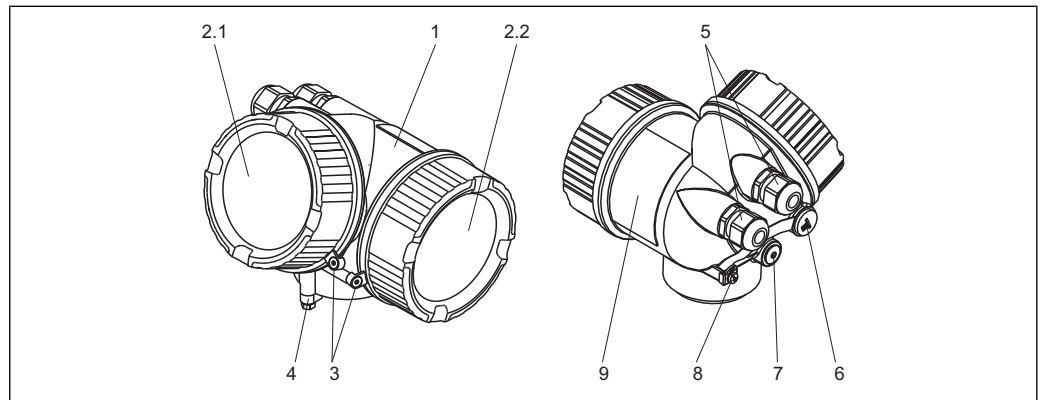

A0013788

Housing GT18 - stainless steel, corrosion-resistant			
No.	Part: material	No.	Part: material
1	Housing: 316L (CF-3M, 1.4404)	5	Cable entry <ul style="list-style-type: none"> ■ Sealing: EMPB ■ Cable gland: 316L (1.4404) ■ Adapter: 316L (1.4435)
2.1	Cover of the electronics compartment <ul style="list-style-type: none"> ■ Cover: 316L (CF-3M, 1.4404) ■ Window: glass ■ Cover seal: EPDM 	6	Dummy plug: 316L (1.4404)
2.2	Cover of the terminal compartment <ul style="list-style-type: none"> ■ Cover: 316L (CF-3M, 1.4404) ■ Cover seal: EPDM 	7	Pressure relief stopper: 316L (1.4404)
3	Cover lock <ul style="list-style-type: none"> ■ Screw: A4 ■ Clamp: 316L (1.4404) 	8	Ground terminal <ul style="list-style-type: none"> ■ Screw: A4 ■ Spring washer: A4 ■ Clamp: 316L (1.4404) ■ Holder: 316L (1.4404)
4	Turn housing <ul style="list-style-type: none"> ■ Screw: A4-70 ■ Clamp: 316L (1.4404) 	9	Identification <ul style="list-style-type: none"> ■ Nameplate: 304 (1.4301) ■ Groove pin: A2

Housing GT19 - plastic			
No.	Part: material	No.	Part: material
1	Housing: PBT	5	Cable entry <ul style="list-style-type: none"> ■ Sealing: EMPB ■ Cable gland: polyamide (PA), nickel-plated brass (CuZn) ■ Adapter: 316L (1.4435)
2.1	Cover of the electronics compartment <ul style="list-style-type: none"> ■ Cover: PA ■ Cover seal: EPDM 	6	Dummy plug: PBT
2.2	Cover of the terminal compartment <ul style="list-style-type: none"> ■ Cover: PBT 		

Housing GT19 - plastic			
No.	Part: material	No.	Part: material
	<ul style="list-style-type: none"> ■ Cover seal: EPDM 	7	Pressure relief stopper: nickel-plated brass (CuZn)
4	Turn housing <ul style="list-style-type: none"> ■ Screw: A4-70 ■ Clamp: 316L (1.4404) 	8	Ground terminal <ul style="list-style-type: none"> ■ Screw: A2 ■ Spring washer: A4 ■ Clamp: 304 (1.4301) ■ Holder: 304 (1.4301)
		9	Identification Nameplate: sticker

Housing GT20 - die-cast aluminum, powder-coated, seawater-resistant			
No.	Part: material	No.	Part: material
1	Housing: AlSi10Mg(<0.1% Cu) Coating: polyester	5	Cable entry <ul style="list-style-type: none"> ■ Sealing: EMPB ■ Cable gland: polyamide (PA), nickel-plated brass (CuZn) ■ Adapter: 316L (1.4435)
2.1	Cover of the electronics compartment <ul style="list-style-type: none"> ■ Cover: AlSi10Mg(<0.1% Cu) ■ Window: glass ■ Cover seal: EPDM 	6	Dummy plug: nickel-plated brass (CuZn)
2.2	Cover of the terminal compartment <ul style="list-style-type: none"> ■ Cover: AlSi10Mg(<0.1% Cu) ■ Cover seal: EPDM 	7	Pressure relief stopper: nickel-plated brass (CuZn)
3	Cover lock <ul style="list-style-type: none"> ■ Screw: A4 ■ Clamp: 316L (1.4404) 	8	Ground terminal <ul style="list-style-type: none"> ■ Screw: A2 ■ Spring washer: A2 ■ Clamp: 304 (1.4301) ■ Holder: 304 (1.4301)
4	Turn housing <ul style="list-style-type: none"> ■ Screw: A4-70 ■ Clamp: 316L (1.4404) 	9	Identification Nameplate: sticker

Mounting bracket

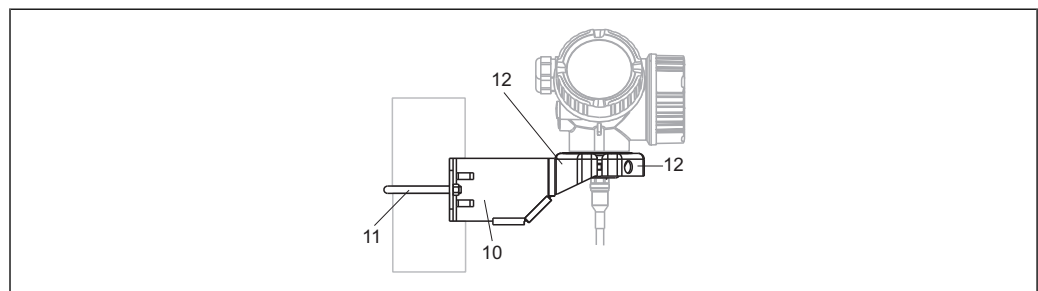

A0015143

Mounting bracket for version "Sensor remote"	
No.	Part: material
10	Bracket: AISI 304 (1.4301), AISI 304L (1.4306)
11	Screw and nuts: A2-70
12	Half-shells: AISI 304L (1.4306)

Weather protection cover

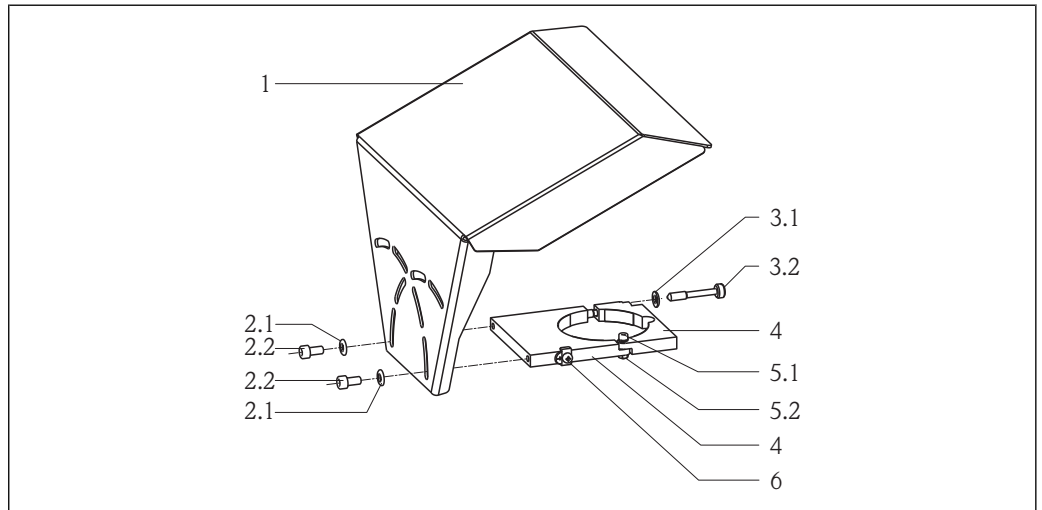

Weather protection cover			
Nr.	Part: material	Nr.	Part: material
1	Protection cover: 304 (1.4301)	4	Bracket: 304 (1.4301)
2.1	Washer: A2	5.1	Cheese head screw: A2-70
2.2	Cheese head screw: A4-70	5.2	Nut: A2
3.1	Washer: A2	6	Ground terminal ■ Screw: A4 ■ Spring washer: A4 ■ Clamp: 316L (1.4404) ■ Holder: 316L (1.4404)
3.2	Tightening screw: 304 (1.4301)		

Operability

Operating concept

Operator-oriented menu structure for user-specific tasks

- Commissioning
- Operation
- Diagnostics
- Expert level

Quick and safe commissioning

- Guided menus ("Make-it-run" wizards) for applications
- Menu guidance with brief explanations of the individual parameter functions

Reliable operation

- Local operation in different languages (see product structure, feature "Additional Operation Language")
- Standardized operation at the device and in the operating tools
- Data storage device (HistoROM) for process and measuring device data with event logbook available at all times - even if electronics modules are replaced

Efficient diagnostics increase measurement reliability

- Remedy information is integrated in plain text
- Diverse simulation options and line recorder functions

Local operation

Order characteristic for "Display; Operation", option C

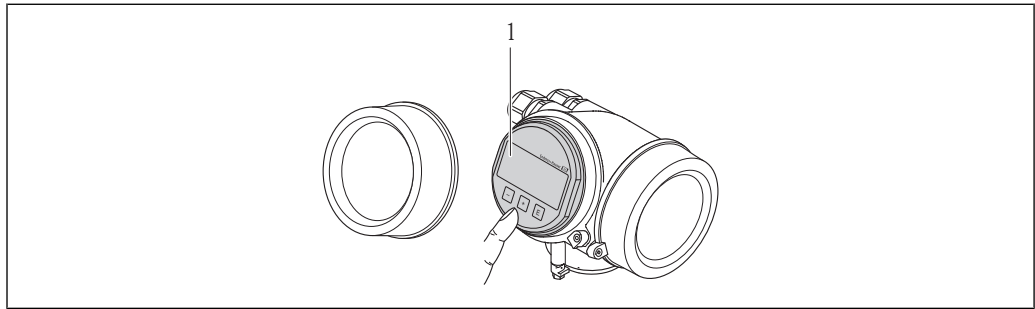

A0015544

1 Operation with pushbuttons

Display elements

- 4-line display
- Format for displaying measured values and status variables can be individually configured
- Permitted ambient temperature for the display: -20 to +60 °C (-4 to +140 °F)
The readability of the display may be impaired at temperatures outside the temperature range.

Operating elements

- Local operation with 3 push buttons (☉, ☉, ☉)
- Operating elements also accessible in various hazardous areas

Additional functionality

- Data backup function
The device configuration can be saved in the display module.
- Data comparison function
The device configuration saved in the display module can be compared to the current device configuration.
- Data transfer function
The transmitter configuration can be transmitted to another device using the display module.

Remote operation

Via HART protocol

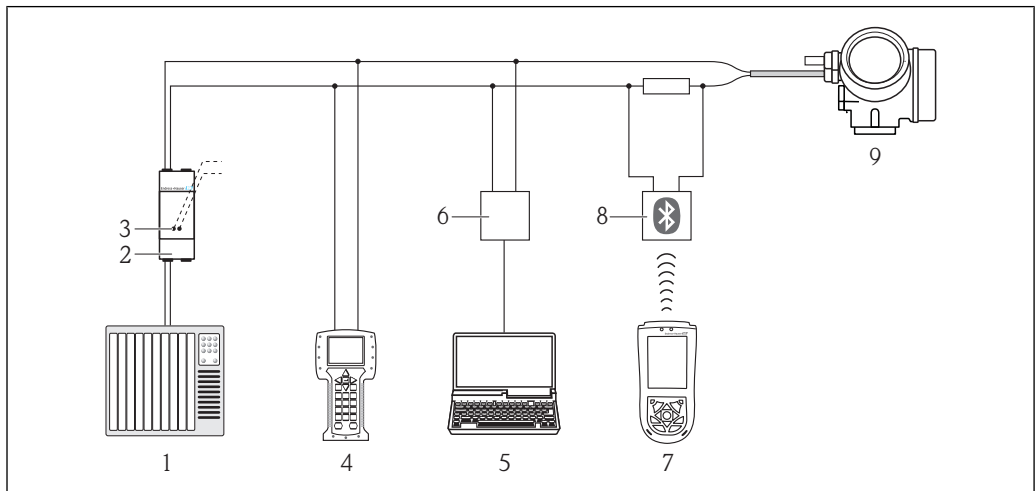

A0013764

14 Options for remote operation via HART protocol

- 1 PLC (programmable logic controller)
- 2 Transmitter power supply unit, e.g. RN221N (with communication resistor)
- 3 Connection for Commubox FXA191, FXA195 and Field Communicator 375, 475
- 4 Field Communicator 375, 475
- 5 Computer with operating tool (e.g. FieldCare, AMS Device Manager, SIMATIC PDM)
- 6 Commubox FXA191 (RS232) or FXA195 (USB)
- 7 Field Xpert SFX100
- 8 VIATOR Bluetooth modem with connecting cable
- 9 Transmitter

Via PROFIBUS PA protocol

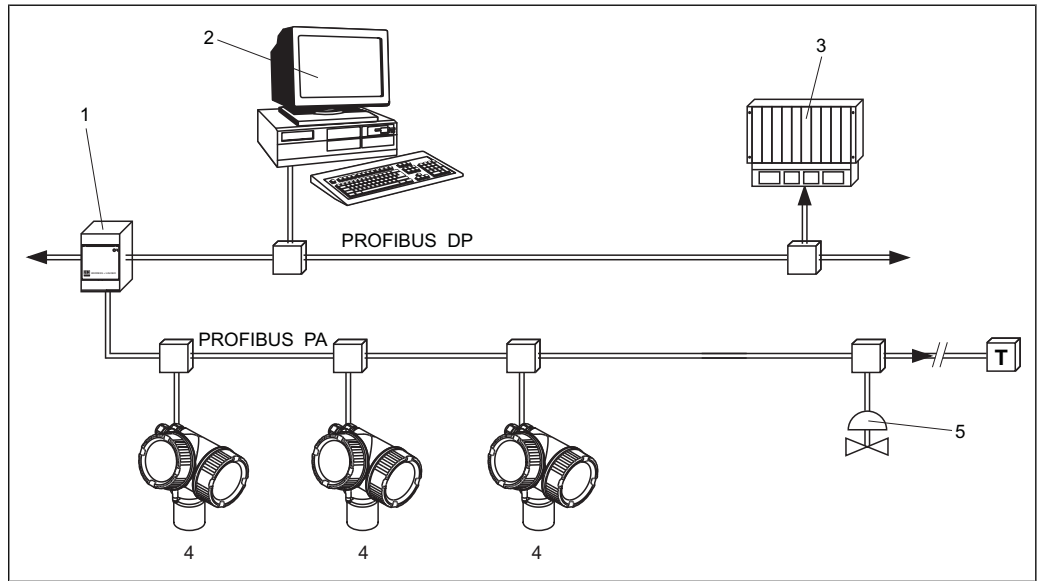

A0015775

- 1 Segment coupler
- 2 Computer with Profiboard/Proficard and operating tool (e.g. FieldCare)
- 3 PLC (Programmable Logic Controller)
- 4 Transmitter
- 5 Additional functions (valves etc.)

Via FOUNDATION Fieldbus

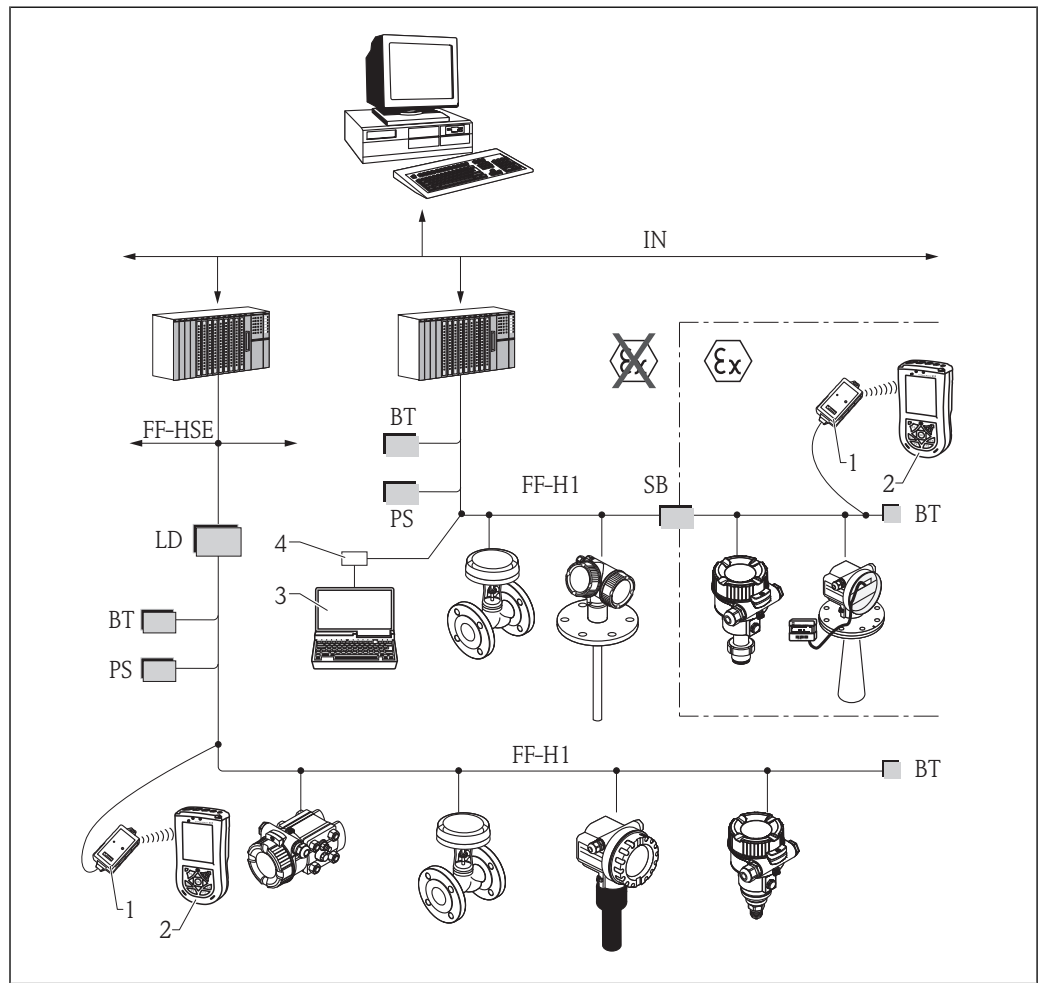

A0017186

15 FOUNDATION Fieldbus system architecture with associated components

- IN Industrial network
- FF- High Speed Ethernet
- HSE
- FF- FOUNDATION Fieldbus-H1
- H1
- LD Linking Device FF-HSE/FF-H1
- PS Bus Power Supply
- SB Safety Barrier
- BT Bus Terminator
- 1 FFblue Bluetooth modem
- 2 Field Xpert SFX100
- 3 FieldCare
- 4 NI-FF interface card

Via service interface (CDI)

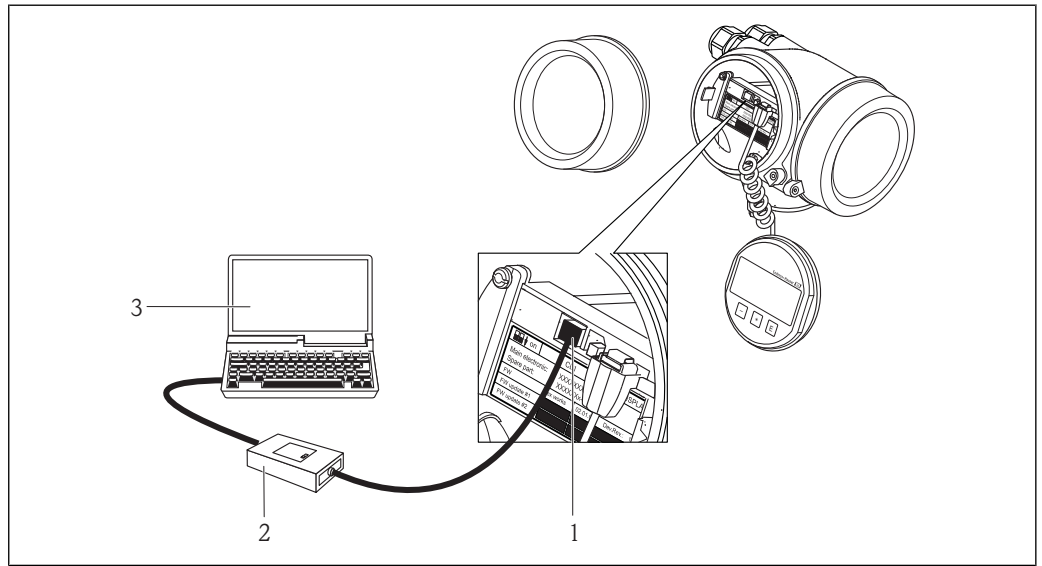

A0014019

- 1 Service interface (CDI) of the measuring device (= Endress+Hauser Common Data Interface)
- 2 Commubox FXA291
- 3 Computer with "FieldCare" operating tool

Integration in tank gauging system

The Endress+Hauser Tank Side Monitor NRF590 provides integrated communications for sites with multiple tanks, each with one or more sensors on the tank, such as radar, spot or average temperature, capacitive probe for water detection and/or pressure sensors. Multiple protocols out of the Tank Side Monitor guarantee connectivity to nearly any of the existing industry standard tank gauging protocols. Optional connectivity of analog 4...20 mA sensors, digital I/O and analog output simplify full tank sensor integration. Use of the proven concept of the intrinsically safe HART bus for all on-tank sensors yields extremely low wiring costs, while at the same time providing maximum safety, reliability and data availability.

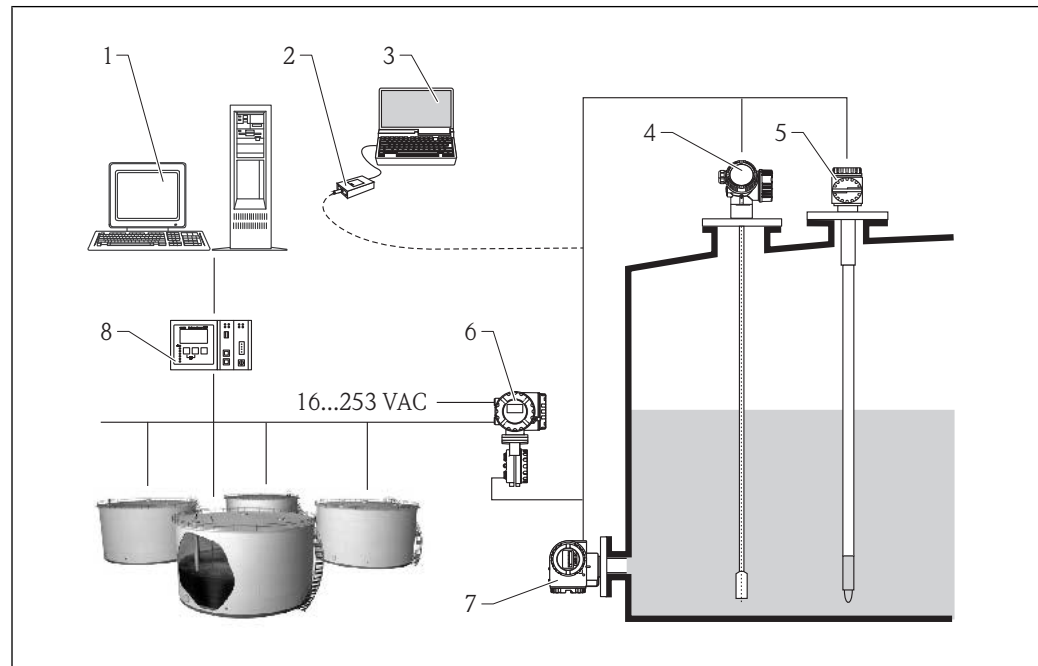

A0016590

16 The complete measuring system consists of:

- 1 Tankvision workstation
- 2 Commubox FXA195 (USB) - optional
- 3 Computer with operating tool (ControlCare) - optional
- 4 Level measuring device
- 5 Temperature measuring device
- 6 Tank Side Monitor NRF590
- 7 Pressure measuring device
- 8 Tankvision Tank Scanner NXA820

System integration via Fieldgate

Vendor Managed Inventory

By using Fieldgates to interrogate tank or silo levels remotely, suppliers of raw materials can provide their regular customers with information about the current supplies at any time and, for example, account for them in their own production planning. For their part, the Fieldgates monitor the configured level limits and, if required, automatically activate the next supply. The spectrum of options here ranges from a simple purchasing requisition via e-mail through to fully automatic order administration by coupling XML data into the planning systems on both sides.

Remote maintenance of measuring equipment

Fieldgates not only transfer the current measured values, they also alert the responsible standby personnel, if required, via e-mail or SMS. In the event of an alarm or also when performing routine checks, service technicians can diagnose and configure connected HART devices remotely. All that is required for this is the corresponding HART operating tool (e.g. FieldCare, ...) for the connected device. Fieldgate passes on the information transparently, so that all options for the respective operating software are available remotely. Some on-site service operations can be avoided by using remote diagnosis and remote configuration and all others can at least be better planned and prepared.

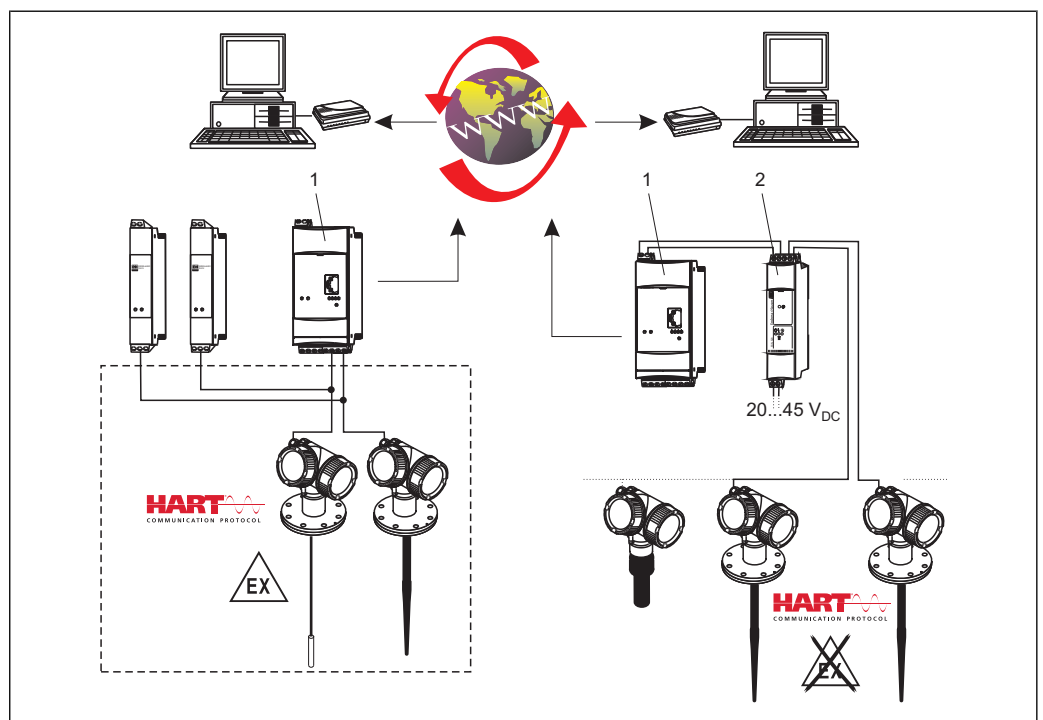







A0011278

17 The complete measuring system consists of devices and:

- 1 Fieldgate FXA520
- 2 Multidrop Connector FXN520

i The number of instruments which can be connected in multidrop mode can be calculated by the "FieldNetCalc" program. A description of this program can be found in Technical Information TI 400F (Multidrop Connector FXN520). The program is available from your Endress+Hauser sales organisation or in the internet at: www.de.endress.com/Download (text search = "Fieldnetcalc").

Certificates and approvals

CE mark	<p>The measuring system meets the legal requirements of the applicable EC guidelines. These are listed in the corresponding EC Declaration of Conformity together with the standards applied.</p> <p>Endress+Hauser confirms successful testing of the device by affixing to it the CE mark.</p>
C-Tick symbol	<p>The measuring system meets the EMC requirements of the "Australian Communications and Media Authority (ACMA)".</p>
Ex approval	<p>The devices are certified for use in hazardous areas and the relevant safety instructions are provided in the separate "Safety Instructions" (XA) document. Reference is made to this document on the nameplate.</p> <p> The separate documentation "Safety Instructions" (XA) containing all the relevant explosion protection data is available from your Endress+Hauser Sales Center. Correlation of documentations to the device (→  96).</p>
Functional Safety	<p>Used for level monitoring (MIN, MAX, range) up to SIL 3 (homogeneous redundancy), independently assessed by TÜV Rhineland as per IEC 61508. Other information see documentation SD00326F: "Functional Safety Manual".</p>
Sanitary compatibility	<p>FMP52 with rod probe is available with sanitary process connections (Dairy coupling DIN 11851, Tri-Clamp).</p> <p> The gap-free connections can be cleaned without residue using the usual cleaning methods.</p> <p>Many versions of the Levellflex M meet the requirements of 3A-Sanitary Standard No. 74.</p> <p>Endress+Hauser confirms this by attaching the 3A symbol.</p>
AD2000	<p>The pressure retaining material 316L (1.4435/1.4404) corresponds to AD2000 - W2/W10.</p>
Pressure Equipment Directive	<p>Conformity assessment was carried out as per Module A, the proof of statical stability and endurance strength as per EN 13445 and AD2000.</p> <p> The FMP54 corresponds to the 97/23/EC Directive (Pressure Equipment Directive). It is a pressure accessory with a volume < 0.1 l, corresponding to Category I.</p> <p>The FMP54 is not suitable for use with unstable gases at nominal pressures above 200 bar (2 900 psi).</p>
Steam boiler approval	<p>The FMP54 is approved as a limiting device for high water (HW) and low water (LW) for liquids in containers which are subject to the requirements of EN12952-11 and EN12953-9 (certified by TÜV Nord). Ordering information (→  86). Further information can be found in the safety instructions for steam boiler approval.</p>
Telecommunications	<p>Complies with part 15 of the FCC rules for an unintentional radiator. All probes meet the requirements for a Class A digital device.</p> <p>In addition, all probes in metallic tanks as well as the coax probe meet the requirements for a Class B digital device.</p>
CRN approval	<p>Some device versions have CRN approval. For a CRN-approved device, a CRN-approved process connection has to be ordered with a CSA approval.</p> <p>(→  79), Product structure, Features 010 "Approval" and 100 "Process Connection".</p> <p> These devices are marked with the registration number 0F14480.5 on the nameplate.</p>
Track record	<p>FMP5x is the upgrade model of the corresponding FMP4x series.</p>
Other standards and guidelines	<ul style="list-style-type: none"> ■ EN 60529 Degrees of protection by housing (IP code) ■ EN 61010-1 Protection Measures for Electrical Equipment for Measurement, Control, Regulation and Laboratory Procedures. ■ IEC/EN 61326 "Emission in accordance with Class A requirements". Electromagnetic compatibility (EMC requirements)

- NAMUR NE 21
Electromagnetic compatibility (EMC) of industrial process and laboratory control equipment.
- NAMUR NE 43
Standardization of the signal level for the breakdown information of digital transmitters with analog output signal.
- NAMUR NE 53
Software of field devices and signal-processing devices with digital electronics
- NAMUR NE 107
Status classification as per NE107
- NAMUR NE 131
Requirements for field devices for standard applications
- IEC61508
Functional safety of electrical/electronic/programmable electronic safety-related systems

Ordering information

Compact device Levelflex

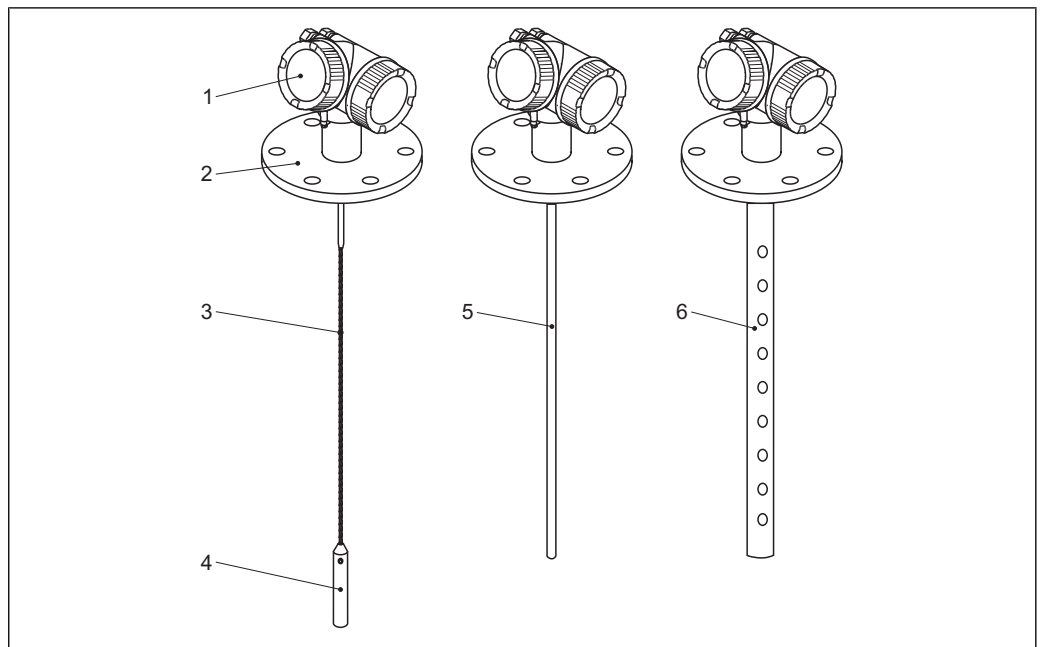

A0012399

18 Design of the Levelflex

- 1 Electronics housing
- 2 Process connection (here as an example: flange)
- 3 Rope probe
- 4 End-of-probe weight
- 5 Rod probe
- 6 Coax probe

Product structure FMP51, FMP52, FMP54

i This overview does not mark options which are mutually exclusive.
Option with * = in preparation

010	Approval:	FMP		
		51	52	54
AA	Non-hazardous area	x	x	x
BA	ATEX II 1G Ex ia IIC T6	x	x	x
BB	ATEX II 1/2G Ex ia IIC T6	x	x	x
BC	ATEX II 1/2G Ex d(ia) IIC T6	x	x	x
BD	ATEX II 1/3G Ex ic(ia) IIC T6	x	x	x
BE	ATEX II 1 D Ex tD IIIC IP6x			x

010	Approval:	FMP		
		51	52	54
BF	ATEX II 1/2 D Ex tD IIIC IP6x			X
BG	ATEX II 3G Ex nA IIC T6	X	X	X
BH	ATEX II 3G Ex ic IIC T6	X	X	X
BL	ATEX II 1/3G Ex nA(ia) IIC T6	X	X	X
B2	ATEX II 1/2G Ex ia IIC T6, 1/2D Ex ia IIIC IP6x	X	X	X
B3	ATEX II 1/2G Ex d(ia) IIC T6, 1/2D Ex tD IIIC IP6x	X	X	X
B4	ATEX II 1/2G Ex ia IIC T6, Ex d(ia) IIC T6	X	X	X
CA	CSA General Purpose	X	X	X
CD	CSA C/US DIP Cl.I,II,III Div.1 Gr.E-G			X
C2	CSA C/US IS Cl.I,II,III Div.1 Gr.A-G, NI Cl.1 Div.2, Ex ia	X	X	X
C3	CSA C/US XP Cl.I,II,III Div.1 Gr.A-G, NI Cl.1 Div.2, Ex d	X	X	X
FB	FM IS Cl.I,II,III Div.1 Gr.A-G, AEx ia, NI Cl.1 Div.2	X	X	X
FD	FM XP Cl.I,II,III Div.1 Gr.A-G, AEx d, NI Cl.1 Div.2	X	X	X
FE	FM DIP Cl.I,II,III Div.1 Gr.E-G			X
IA	IECEX Zone 0 Ex ia IIC T6 Ga	X	X	X
IB	IECEX Zone 0/1 Ex ia IIC T6 Ga/Gb	X	X	X
IC	IECEX Zone 0/1 Ex d(ia) IIC T6 Ga/Gb	X	X	X
ID	IECEX Zone 0/2 Ex ic(ia) IIC T6 Ga/Gc	X	X	X
IE	IECEX Zone 20 tD IIIC A20 IP6x Da			X
IF	IECEX Zone 20/21 tD IIIC A20/21 IP6x Da/Db			X
IG	IECEX Zone 2 Ex nA IIC T6 Gc	X	X	X
IH	IECEX Zone 2 Ex ic IIC T6 Gc	X	X	X
IL	IECEX zone 0/2 Ex nA(ia) IIC T6 Ga/Gc	X	X	X
I2	IECEX zone 0/1 Ex ia IIC T6 Ga/Gb, zone 20/21 Ex ia IIIC A20/21 IP6x Da/Db	X	X	X
I3	IECEX Zone 0/1 Ex d(ia) IIC T6 Ga/Gb, Zone 20/21 Ex tD IIIC A20/21 IP6x Da/Db	X	X	X
NA	NEPSI zone 0 Ex ia IIC T6 Ga	X	X	X
NB	NEPSI zone 0/1 Ex ia IIC T6 Ga/Gb	X	X	X
NC	NEPSI zone 0/1 Ex d(ia) IIC T6 Ga/Gb	X	X	X
NF	NEPSI zone 20/21 tD IIIC A20/21 IP6x Da/Db			X
NG	NEPSI zone 2 Ex nA II T6 Gc	X	X	X
NH	NEPSI zone 2 Ex ic IIC T6 Gc	X	X	X
N2	NEPSI zone 0/1 Ex ia IIC T6 Ga/Gb, zone 20/21 Ex iaD 20/21 T*	X	X	X
N3	NEPSI zone 0/1 Ex d(ia) IIC T6 Ga/Gb, DIP A20/21 T* IP6x	X	X	X
8A	FM/CSA IS+XP Cl.I,II,III Div.1 Gr.A-G	X	X	X
99	Special version, TSP-no. to be sepc.	X	X	X
020	Power Supply, Output	FMP		
		51	52	54
A	2-wire; 4-20mA HART	X	X	X
C	2-wire; 4-20mA HART, 4-20mA	X	X	X
E	2-wire; FOUNDATION Fieldbus, switch output	X	X	X
G	2-wire. PROFIBUS PA, switch output	X	X	X
K	4-wire 90-253VAC; 4-20mA HART	X	X	X

020	Power Supply, Output	FMP		
		51	52	54
L	4-wire 10,4-48VDC; 4-20mA HART	X	X	X
Y	Special version, TSP-no. to be sepc.	X	X	X
030	Display, Operation:	FMP		
A	W/o, via communication	X	X	X
C	SD02 4-line, push buttons + data backup function	X	X	X
Y	Special version, TSP-no. to be sepc.	X	X	X
040	Housing:	51	52	54
A	GT19 dual compartment, Plastics PBT	X	X	X
B	GT18 dual compartment, 316L	X	X	X
C	GT20 dual compartment, Alu coated	X	X	X
Y	Special version, TSP-no. to be sepc.	X	X	X
050	Electrical connection:	FMP		
A	Gland M20, IP66/68 NEMA4X/6P	X	X	X
B	Thread M20, IP66/68 NEMA4X/6P	X	X	X
C	Thread G1/2, IP66/68 NEMA4X/6P	X	X	X
D	Thread NPT1/2, IP66/68 NEMA4X/6P	X	X	X
I	Plug M12, IP66/68 NEMA4X/6P	X	X	X
M	Plug 7/8", IP66/68 NEMA4X/6P	X	X	X
Y	Special version, TSP-no. to be sepc.	X	X	X
060	Probe:	FMP		
		51	52	54
AA mm, rod 8mm 316L	X		
AB inch, rod 1/3" 316L	X		
AC mm, rod 12mm 316L	X		
AD inch, rod 1/2" 316L	X		
AE mm, rod 16mm 316L			X
AF inch, rod 0.63in 316L			X
AL mm, rod 12mm AlloyC	X		
AM inch, rod 1/2" AlloyC	X		
BA mm, rod 16mm 316L, 500mm divisible	X		X
BB inch, rod 0.63in 316L, 20 inch divisible	X		X
BC mm, rod 16mm 316L, 1000mm divisible	X		X
BD inch, rod 0.63in 316L, 40 inch divisible	X		X
CA mm, rod 16mm PFA>316L		X	
CB inch, rod 0.63in PFA>316L		X	
LA mm, rope 4mm 316	X		X
LB inch, rope 1/6" 316	X		X
MB mm, rope 4mm 316, max 300mm nozzle height, center rod	X		
MD inch, rope 1/6" 316, max 12inch nozzle height, center rod	X		
OA mm, rope 4mm PFA>316, max 150mm		X	

060	Probe:	FMP		
		51	52	54
OB mm, rope 4mm PFA>316, max 300mm		x	
OC inch, rope 1/6" PFA>316, max 6inch		x	
OD inch, rope 1/6" PFA>316, max 12inch		x	
UA mm, coax 316L	x		x
UB inch, coax 316L	x		x
UC mm, coax AlloyC	x		
UD inch, coax AlloyC	x		
YY	Special version, TSP-no. to be sepc.	x	x	x
090	Seal:	FMP		
		51	52	54
A4	Viton, -30...150°C	x		
B3	EPDM, -40...120°C	x		
C3	Kalrez, -20...200°C; saturated steam max. 150°C	x		
D1	Graphite, -196...280°C (XT); saturated steam max. 200°C			x
D2	Graphite, -196...450°C (HT)			x
Y9	Special version, TSP-no. to be sepc.	x	x	x
100	Process connection:	FMP		
		51	52	54
AAJ	2" 300/600lbs RF, 316/316L flange ANSI B16.5 (CRN)			x
ABJ	3" 300/600lbs RF, 316/316L flange ANSI B16.5 (CRN)			x
AEJ	1-1/2" 150lbs RF, 316/316L flange ANSI B16.5 (CRN)	x		
AEK	1-1/2" 150lbs, PTFE>316/316L flange ANSI B16.5 (CRN)		x	
AEM	1-1/2" 150lbs, AlloyC>316/316L flange ANSI B16.5 (CRN)	x		
AFJ	2" 150lbs RF, 316/316L flange ANSI B16.5 (CRN)	x		x
AFK	2" 150lbs, PTFE>316/316L flange ANSI B16.5 (CRN)		x	
AFM	2" 150lbs, AlloyC>316/316L flange ANSI B16.5 (CRN)	x		
AGJ	3" 150lbs RF, 316/316L flange ANSI B16.5 (CRN)	x		x
AGK	3" 150lbs, PTFE>316/316L flange ANSI B16.5 (CRN)		x	
AGM	3" 150lbs, AlloyC>316/316L flange ANSI B16.5 (CRN)	x		
AHJ	4" 150lbs RF, 316/316L flange ANSI B16.5 (CRN)	x		x
AHK	4" 150lbs, PTFE>316/316L flange ANSI B16.5 (CRN)		x	
AJJ	6" 150lbs RF, 316/316L flange ANSI B16.5 (CRN)	x		
AJK	6" 150lbs, PTFE>316/316L flange ANSI B16.5 (CRN)		x	
AKJ	8" 150lbs RF, 316/316L flange ANSI B16.5 (CRN)	x		
AOJ	4" 600lbs RF, 316/316L flange ANSI B16.5 (CRN)			x
AQJ	1-1/2" 300lbs RF, 316/316L flange ANSI B16.5 (CRN)	x		
AOK	1-1/2" 300lbs, PTFE>316/316L flange ANSI B16.5		x	
AQM	1-1/2" 300lbs, AlloyC>316/316L flange ANSI B16.5 (CRN)	x		
ARJ	2" 300lbs RF, 316/316L flange ANSI B16.5 (CRN)	x		
ARK	2" 300lbs, PTFE>316/316L flange ANSI B16.5 (CRN)		x	
ARM	2" 300lbs, AlloyC>316/316L flange ANSI B16.5 (CRN)	x		
ASJ	3" 300lbs RF, 316/316L flange ANSI B16.5 (CRN)	x		

100	Process connection:	FMP		
		51	52	54
ASK	3" 300lbs, PTFE>316/316L flange ANSI B16.5 (CRN)		X	
ASM	3" 300lbs, AlloyC>316/316L flange ANSI B16.5 (CRN)	X		
ATJ	4" 300lbs RF, 316/316L flange ANSI B16.5 (CRN)	X		X
ATK	4" 300lbs, PTFE>316/316L flange ANSI B16.5 (CRN)		X	
AZJ	4" 900lbs RF, 316/316L flange ANSI B16.5 (CRN)			X
A6J	2" 1500lbs RF, 316/316L flange ANSI B16.5 (CRN)			X
A7J	3" 1500lbs RF, 316/316L flange ANSI B16.5 (CRN)			X
A8J	4" 1500lbs RF, 316/316L flange ANSI B16.5 (CRN)			X
CFJ	DN50 PN10/16 B1, 316L flange EN1092-1	X		X
CFK	DN50 PN10/16, PTFE>316L flange EN1092-1		X	
CFM	DN50 PN10/16, AlloyC>316L flange EN1092-1	X		
CGJ	DN80 PN10/16 B1, 316L flange EN1092-1	X		X
CGK	DN80 PN10/16, PTFE>316L flange EN1092-1		X	
CGM	DN80 PN10/16, AlloyC>316L flange EN1092-1	X		
CHJ	DN100 PN10/16 B1, 316L flange EN1092-1	X		X
CHK	DN100 PN10/16, PTFE>316L flange EN1092-1		X	
CHM	DN100 PN10/16, AlloyC>316L flange EN1092-1	X		
CJJ	DN150 PN10/16 B1, 316L flange EN1092-1	X		
CJK	DN150 PN10/16, PTFE>316L flange EN1092-1		X	
CKJ	DN200 PN16 B1, 316L flange EN1092-1	X		
CQJ	DN40 PN10-40 B1, 316L flange EN1092-1	X		
CQK	DN40 PN10-40, PTFE>316L flange EN1092-1		X	
CQM	DN40 PN10-40, AlloyC>316L flange EN1092-1	X		
CRJ	DN50 PN25/40 B1, 316L flange EN1092-1	X		X
CRK	DN50 PN25/40, PTFE>316L flange EN1092-1		X	
CRM	DN50 PN25/40, AlloyC>316L flange EN1092-1	X		
CSJ	DN80 PN25/40 B1, 316L flange EN1092-1	X		X
CSK	DN80 PN25/40, PTFE>316L flange EN1092-1		X	
CSM	DN80 PN25/40, AlloyC>316L flange EN1092-1	X		
CTJ	DN100 PN25/40 B1, 316L flange EN1092-1	X		X
CTK	DN100 PN25/40, PTFE>316L flange EN1092-1		X	
CTM	DN100 PN25/40, AlloyC>316L flange EN1092-1	X		
GDJ	Thread ISO228 G3/4, 316L	X		
GGJ	Thread ISO228 G1-1/2, 316L (CRN)	X		
GIJ	Thread ISO228 G1-1/2, 200bar, 316L (CRN)			X
GJJ	Thread ISO228 G1-1/2, 400bar, 316L (CRN)			X
KEJ	10K 40 RF, 316L flange JIS B2220	X		
KEK	10K 40, PTFE>316L flange JIS B2220		X	
KFJ	10K 50 RF, 316L flange JIS B2220	X		X
KFK	10K 50, PTFE>316L flange JIS B2220		X	
KGJ	10K 80 RF, 316L flange JIS B2220	X		X
KGK	10K 80, PTFE>316L flange JIS B2220		X	

100	Process connection:	FMP		
		51	52	54
KHJ	10K 100 RF, 316L flange JIS B2220	x		x
KHK	10K 100, PTFE>316L flange JIS B2220		x	
K3J	63K 50 RF, 316L flange JIS B2220			x
K4J	63K 80 RF, 316L flange JIS B2220			x
K5J	63K 100 RF, 316L flange JIS B2220			x
LNJ	Fisher 249B/259B cages 600lbs, 316L, torque tube displacer flange			x
LPJ	Fisher 249N cages 900lbs, 316L, torque tube displacer flange			x
LOJ	Masoneilan 7-1/2" 600lbs, 316L torque tube displacer flange			x
MOK	DIN11851 DN50 PN40 cap-nut, PTFE>316L		x	
PDJ	DN50 PN63 B2, 316L flange EN1092-1			x
PEJ	DN80 PN63 B2, 316L flange EN1092-1			x
PFJ	DN100 PN63 B2, 316L flange EN1092-1			x
PNJ	DN50 PN100 B2, 316L flange EN1092-1			x
PPJ	DN80 PN100 B2, 316L flange EN1092-1			x
PQJ	DN100 PN100 B2, 316L flange EN1092-1			x
RAJ	Thread ANSI MNPT1-1/2, 200bar, 316L (CRN)			x
RBJ	Thread ANSI MNPT1-1/2, 400bar, 316L (CRN)			x
RDJ	Thread ANSI MNPT3/4, 316L	x		
RGJ	Thread ANSI MNPT1-1/2, 316L (CRN)	x		
TAK	Tri-Clamp ISO2852 DN40-51 (2"), 3A, PTFE>316L (CRN)		x	
TDK	Tri-Clamp ISO2852 DN40-51 (2"), PTFE>316L (CRN)		x	
TFK	Tri-Clamp ISO2852 DN70-76.1 (3"), PTFE>316L (CRN)		x	
TJK	Tri-Clamp ISO2852 DN38 (1-1/2"), PTFE>316L (CRN)		x	
TLK	Tri-Clamp ISO2852 DN70-76.1 (3"), 3A, PTFE>316L (CRN)		x	
TNK	Tri-Clamp ISO2852 DN38 (1-1/2"), 3A, PTFE>316L (CRN)		x	
WQJ	DN50 PN25/40 E, 316L flange EN1092-1	x		
WRJ	DN80 PN25/40 E, 316L flange EN1092-1	x		
WSJ	DN100 PN25/40 E, 316L flange EN1092-1	x		x
YYY	Special version, TSP-no. to be sepc.	x	x	x
500	Additional Operation Language:	FMP		
		51	52	54
AA	English	x	x	x
AB	German	x	x	x
AC	French	x	x	x
AD	Spanish	x	x	x
AE	Italian	x	x	x
AF	Dutch	x	x	x
AG	Portuguese	x	x	x
AH	Polish	x	x	x
AI	Russian	x	x	x
AK	Chinese simplified	x	x	x
AL	Japanese	x	x	x

500	Additional Operation Language:	FMP		
		51	52	54
AM	Korean	x	x	x
AR	Czech	x	x	x
540	Application Package: <i>(Multiple options can be selected)</i>	FMP		
		51	52	54
EB	Interface measurement	x	x	x
EF	Gas Phase Compensation, $L_{ref} = 300\text{mm}$ If this option is selected for rod probes, the inner diameter iD of the stilling well or bypass must be specified as it determines the diameter of the rod probe within the reference length (→ 32).			x
EG	Gas Phase Compensation, $L_{ref} = 550\text{mm}$ If this option is selected for rod probes, the inner diameter iD of the stilling well or bypass must be specified as it determines the diameter of the rod probe within the reference length (→ 32).			x
E9	Special version, TSP-no. to be sepc.	x	x	x
550	Calibration:	FMP		
		51	52	54
F4	5-point linearity protocol (→ 87)	x	x	x
F9	Special version, TSP-no. to be sepc.	x	x	x
570	Service: <i>(Multiple options can be selected)</i>	FMP		
		51	52	54
HC	PWIS free, PWIS = paint-wetting impairment substances	x	x	x
IJ	Customized parametrization HART (→ 88)	x	x	x
IK	Customized parametrization PA (→ 88)	x	x	x
IL	Customized parametrization FF (→ 88)	x	x	x
IW	W/o Tooling DVD (FieldCare setup)	x	x	x
I9	Special version, TSP-no. to be sepc.	x	x	x
580	Test, Certificate: <i>(Multiple options can be selected)</i>	FMP		
		51	52	54
JA	3.1 Material certificate, wetted metallic parts, EN10204-3.1 inspection certificate	x		x
JB	Conformity to NACE MR0175, wetted metallic parts	x		x
JD	3.1 Material certificate, pressure retaining parts, EN10204-3.1 inspection certificate		x	
JE	Conformity to NACE MR0103, wetted metallic parts	x		x
KD	Helium leak test, internal procedure, inspection certificate	x		x
KE	Pressure test, internal procedure, inspection certificate	x	x	x
KG	3.1 Material certificate+PMI test (XRF) internal procedure, wetted metallic parts, EN10204-3.1 inspection certificate	x		x
KP	Liquid penetrant test AD2000-HP5-3(PT), wetted/pressure retaining metallic parts, inspection certificate	x		x
KQ	Liquid penetrant test ISO23277-1 (PT), wetted/pressure retaining metallic parts, inspection certificate	x		x
KR	Liquid penetrant test ASME VIII-1 (PT), wetted/pressure retaining metallic parts, inspection certificate	x		x
KS	WPQR, WPS to ISO15614/ASME IX/Norsok, wetted/pressure retaining metallic parts	x		x
K9	Special version, TSP-no. to be sepc.	x	x	x

590	Additional Approval: <i>(Multiple options can be selected)</i>	FMP		
		51	52	54
LA	SIL	x	x	x
LC	*WHG overfill prevention	x	x	x
L9	Special version, TSP-no. to be sepc.	x	x	x
600	Probe Design: <i>(Multiple options can be selected)</i>	FMP		
		51	52	54
MB	Sensor remote, 3m/9ft cable, detachable+mounting bracket	x	x	x
M9	Special version, TSP-no. to be sepc.	x	x	x
610	Accessory mounted: <i>(Multiple options can be selected)</i>	FMP		
		51	52	54
NC	Gas-tight feed through	x	x	
OA	Rod center washer d=75mm/2.95", 316L pipe diameter DN80/3" + DN100/4"	x		x
OB	Rod center washer d=45mm/1.77", 316L pipe diameter DN50/2" + DN65/2-1/2"	x		x
OC	Rope center washer d=75mm/2.95", 316L pipe diameter DN80/3" + DN100/4"	x		x
OD	Rod center washer d=48-95mm/1.88-3.74", PEEK, interface measurement, pipe diameter DN50/2" to DN100/4"	x		x
OE	Rod center washer d=37mm/1.45", PFA, interface measurement, pipe diameter DN40/1-1/2" + DN50/2"	x	x	x
O9	Special version, TSP-no. to be sepc.	x	x	x
620	Accessory enclosed: <i>(Multiple options can be selected)</i>	FMP		
		51	52	54
PB	Weather protection cover	x	x	x
PG	Mounting kit, insulated, rope	x		
R9	Special version, TSP-no. to be sepc.	x	x	x
850	Firmware Version:	FMP		
		51	52	54
75	01.01.zz, HART, DevRev02	x	x	x
76	01.00.zz, FF, DevRev01	x	x	x
77	01.00.zz, PROFIBUS PA, DevRev01	x	x	x
78	01.00.zz, HART, DevRev01	x	x	x
895	Tagging: <i>(Multiple options can be selected)</i>	FMP		
		51	52	54
Z1	Tagging (TAG), see additional spec.	x	x	x
Z2	Bus address, see additional spec.	x	x	x

5 point linearity protocol

i The following notes must be taken into account if option F4 ("5 point linearity protocol") has been selected in feature 550 ("Calibration").

The five points of the linearity protocol are evenly distributed throughout the measuring range (0% to 100%). In order to define the measuring range, **Empty calibration** (E) and **Full calibration** (F) have to be specified ⁶⁾.

The following restrictions have to be taken into account when defining E and F:

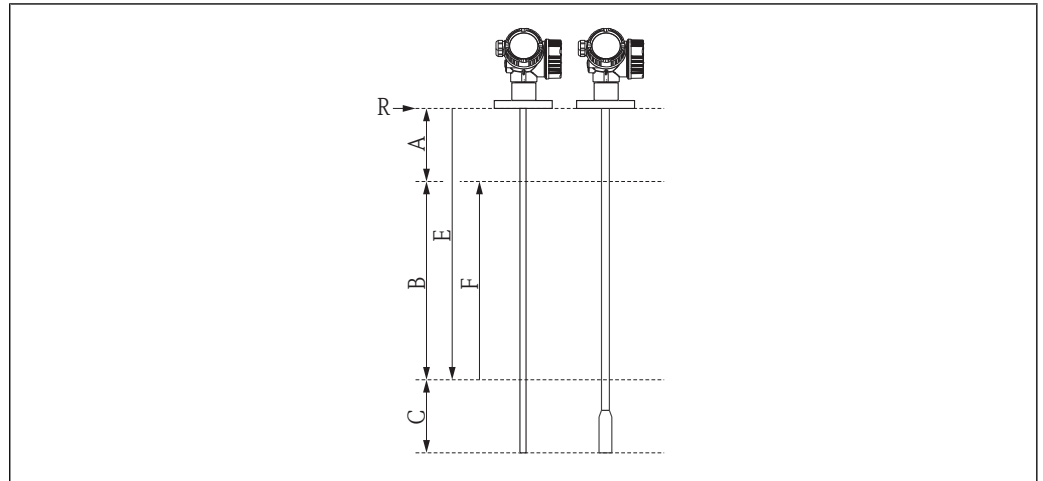

A0014673

Sensor	Minimum distance between reference point (R) and 100% level	Minimum measuring range
FMP51 FMP52 FMP54 w/o gas phase compensation	A ≥ 250 mm (10 in)	B ≥ 400 mm (16 in)
FMP54 with gas phase compensation, L _{ref} = 300 mm	A ≥ 450 mm (18 in)	B ≥ 400 mm (16 in)
FMP54 with gas phase compensation, L _{ref} = 550 mm	A ≥ 700 mm (24 in)	B ≥ 400 mm (16 in)

Type of probe	Minimum distance from end of probe to 0% level	Maximum value for "empty calibration"
Rod	C ≥ 100 mm (4 in)	E ≤ 3.9 m (12.8 ft)
Coax	C ≥ 100 mm (4 in)	E ≤ 5.9 m (19.4 ft)
Rope	C ≥ 1000 mm (40 in)	E ≤ 23 m (75 ft)

- i** For rod and rope probes the linearity check is performed with the complete device.
- i** For coax probes the electronics is mounted to a reference rod probe and the linearity check is performed to this configuration.
- i** In both cases the linearity is checked under reference conditions.

i The selected values of **Empty calibration** and **Full calibration** are only used to record the linearity protocol and are reset to their probe specific default values thereafter. If values different from the default are required, they must be ordered as a customized parametrization (→ 88).

6) If E and F are not specified, probe dependent default values will be used instead.

Customized parametrization

If the option IJ "Customized parametrization HART", IK "Customized parametrization PA" or IL "Customized parametrization FF" has been selected in feature 570 "Service", customer specific presettings can be selected for the following parameters:

Parameter	Communication	Selection list / range of values
Setup → Distance unit	<ul style="list-style-type: none"> ■ HART ■ PA ■ FF 	<ul style="list-style-type: none"> ■ in ■ mm
Setup → Empty calibration	<ul style="list-style-type: none"> ■ HART ■ PA ■ FF 	0 to 45 m (0 to 147 ft)
Setup → Full calibration	<ul style="list-style-type: none"> ■ HART ■ PA ■ FF 	0 to 45 m (0 to 147 ft)
Setup → Adv. Setup → Current output 1/2 → Damping	HART	0 to 999,9 s
Setup → Adv. Setup → Current output 1/2 → Failure mode	HART	<ul style="list-style-type: none"> ■ Min ■ Max ■ Last valid value
Expert → Comm. → HART config. → Burst mode	HART	<ul style="list-style-type: none"> ■ Off ■ On

Accessories

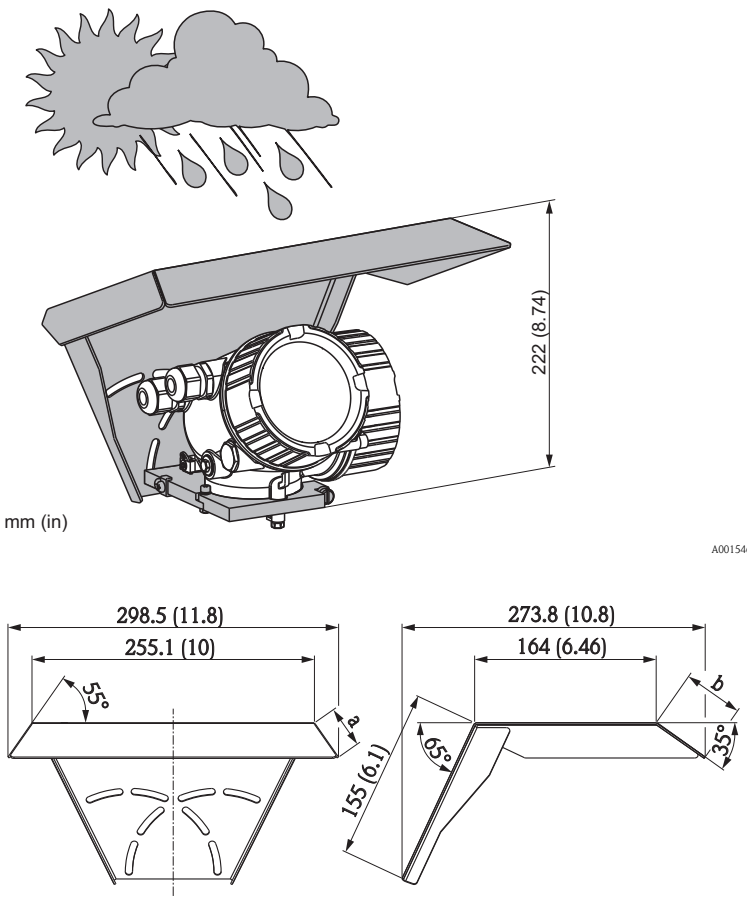
Device-specific accessories	Accessory	Description
	Weather protection cover	 <p>mm (in)</p> <p>A0015466</p> <p>mm (in)</p> <p>A0015472</p> <p><i>a</i> 37.8 mm (1.49 in) <i>b</i> 54 mm (2.13 in)</p> <p>i The weather protection cover can be ordered together with the device (product structure, feature 620 "Accessory Enclosed", option PB "Weather Protection Cover"). Alternatively, it can be separately ordered as an accessory; order code 71132889.</p>



Accessory	Description
Mounting bracket for the electronics housing	<p> A Wall mounting B Pipe mounting </p> <p> For the "Sensor remote" device version (see feature 060 of the product structure), the mounting bracket is part of the delivery. If required, it can also be ordered as an accessory (order code 71102216). </p>

Accessory	Description																		
Extension rod / centering HMP40 <ul style="list-style-type: none"> ■ can be used for: FMP54 ■ Admissible temperature at lower nozzle edge: -40 to 150 °C (-40 to 302 °F) ■ Additional information: SD01002F 	<p> 1 Nozzle height 2 Extension rod 3 Center washer </p> <table border="1" data-bbox="673 1688 1437 2074"> <thead> <tr> <th data-bbox="683 1697 730 1727">010</th> <th data-bbox="737 1697 1437 1727">Approval:</th> </tr> </thead> <tbody> <tr> <td data-bbox="683 1736 730 1765">A</td> <td data-bbox="737 1736 1437 1765">A: Non-hazardous area</td> </tr> <tr> <td data-bbox="683 1774 730 1803">M</td> <td data-bbox="737 1774 1437 1803">M: FM DIP Cl.II Div.1 Gr.E-G N.I., zone 21,22</td> </tr> <tr> <td data-bbox="683 1812 730 1841">P</td> <td data-bbox="737 1812 1437 1841">P: CSA DIP Cl.II Div.1 Gr.G + coal dust N.I.</td> </tr> <tr> <td data-bbox="683 1850 730 1879">S</td> <td data-bbox="737 1850 1437 1879">S: FM Cl.I, II, III Div.1 Gr.A-G N.I., zone 0,1,2,20,21,22</td> </tr> <tr> <td data-bbox="683 1888 730 1917">U</td> <td data-bbox="737 1888 1437 1917">U: CSA Cl.I, II, III Div.1 Gr.A-G N.I., zone 0,1,2</td> </tr> <tr> <td data-bbox="683 1926 730 1955">1</td> <td data-bbox="737 1926 1437 1955">1: ATEX II 1G</td> </tr> <tr> <td data-bbox="683 1964 730 1993">2</td> <td data-bbox="737 1964 1437 1993">2: ATEX II 1D</td> </tr> <tr> <td data-bbox="683 2047 730 2076">020</td> <td data-bbox="737 2047 1437 2076">Extension rod; nozzle height:</td> </tr> </tbody> </table>	010	Approval:	A	A: Non-hazardous area	M	M: FM DIP Cl.II Div.1 Gr.E-G N.I., zone 21,22	P	P: CSA DIP Cl.II Div.1 Gr.G + coal dust N.I.	S	S: FM Cl.I, II, III Div.1 Gr.A-G N.I., zone 0,1,2,20,21,22	U	U: CSA Cl.I, II, III Div.1 Gr.A-G N.I., zone 0,1,2	1	1: ATEX II 1G	2	2: ATEX II 1D	020	Extension rod; nozzle height:
010	Approval:																		
A	A: Non-hazardous area																		
M	M: FM DIP Cl.II Div.1 Gr.E-G N.I., zone 21,22																		
P	P: CSA DIP Cl.II Div.1 Gr.G + coal dust N.I.																		
S	S: FM Cl.I, II, III Div.1 Gr.A-G N.I., zone 0,1,2,20,21,22																		
U	U: CSA Cl.I, II, III Div.1 Gr.A-G N.I., zone 0,1,2																		
1	1: ATEX II 1G																		
2	2: ATEX II 1D																		
020	Extension rod; nozzle height:																		

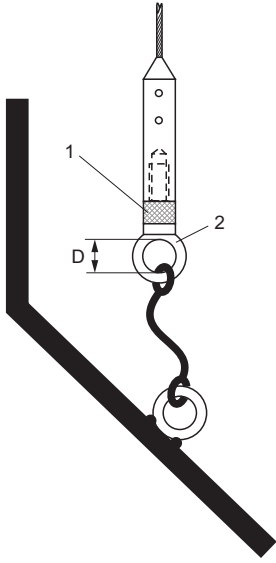
Accessory	Description	
	1	115mm; 150-250mm / 6-10"
	2	215mm; 250-350mm / 10-14"
	3	315mm; 350-450mm / 14-18"
	4	415mm; 450-550mm / 18-22"
	9	Special version, TSP-no. to be spec.
	030 Center washer:	
	A	Not selected
	B	DN40 / 1-1/2", inside-d. = 40-45mm, PPS
	C	DN50 / 2", inside-d. = 50-57mm, PPS
	D	DN80 / 3", inside-d. = 80-85mm, PPS
	E	DN80 / 3", inside-d. = 76-78mm, PPS
	G	DN100 / 4", inside-d. = 100-110mm, PPS
	H	DN150 / 6", inside-d. = 152-164mm, PPS
	J	DN200 / 8", inside-d. = 210-215mm, PPS
	K	DN250 / 10", inside-d. = 253-269mm, PPS
	Y	Special version, TSP-no. to be spec.

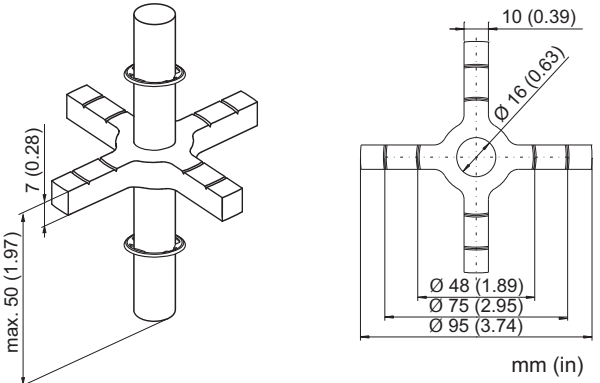
Accessory	Description
Mounting kit, isolated	 <p data-bbox="1388 824 1441 840">A0013586</p> <p data-bbox="673 851 869 907"> <i>1 Insulating sleeve</i> <i>2 Eye-bolt</i> </p> <p data-bbox="673 929 1093 985"> For reliably insulated fixing of the probe. Maximum process temperature: 150 °C (300 °F) </p> <p data-bbox="673 996 1220 1019"> For rope probes 4 mm (1/6 in) or 6 mm (1/4 in) with PA>steel: </p> <ul data-bbox="673 1025 949 1097" style="list-style-type: none"> ■ Eye-bolt M8 DIN 580 ■ Diameter D = 20 mm (0.8 in) ■ Order-No.: 52014249 <p data-bbox="673 1108 1220 1131"> For rope probes 6 mm (1/4 in) or 8 mm (1/3 in) with PA>steel: </p> <ul data-bbox="673 1137 949 1209" style="list-style-type: none"> ■ Eye-bolt M10 DIN 580 ■ Diameter D = 25 mm (1 in) ■ Order-No.: 52014250 <p data-bbox="673 1220 1380 1276"> Due to the risk of electrostatic charge, the insulating sleeve is not suitable for use in hazardous areas. In these cases the fixing must be reliably grounded. </p> <p data-bbox="673 1288 1412 1373"> i The mounting kit can also be ordered directly with the device (see the Levelflex product structure, feature 620 "Accessory Enclosed", option PG "Mounting kit, isolated, rope"). </p>

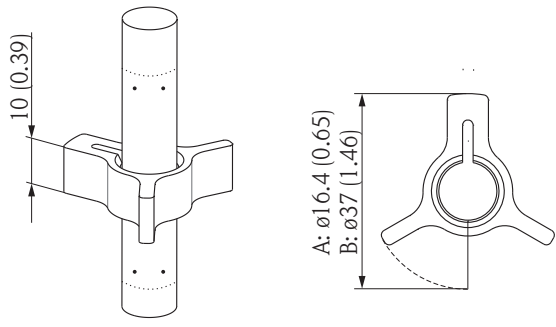
Accessory	Description
<p>Centering disk PEEK \varnothing 48 to 95 mm (1.89 to 3.74 inch) can be used for</p> <ul style="list-style-type: none"> ■ FMP51 ■ FMP54 	<div style="display: flex; justify-content: space-around; align-items: flex-start;">  </div> <p style="text-align: right; font-size: small;">A0014576</p> <p>The centering disk is suitable for probes with a rod diameter of \varnothing 16 mm (0.63in) and can be used in pipes from DN40 (1 1/2") up to DN100 (4"). Markings on the 4-leg centering disk ensure a simple tailoring. Hence the centering disk can be adapted to the pipe diameter. See also Operating Instructions BA377F.</p> <ul style="list-style-type: none"> ■ Material of centering disk: PEEK (statically dissipative) ■ Material of retaining rings: PH15-7Mo (UNS S15700) ■ Admissible process temperature: -60 to +200 °C (-76 to +392 °F) ■ Order code: 71069064 <p>i If the centering disk is inserted in a bypass, it must be positioned below the lower bypass outlet. This has to be accounted for when choosing the probe length. Generally, the centering disk should not be mounted higher than 50 mm (1.97") from the probe end. It is recommended not to insert the PEEK centering disk in the measuring range of the rod probe.</p> <p>i The PEEK centering disk can also be ordered directly with the device (see the Levelflex product structure, feature 610 "Accessory mounted", option OD). In this case it is not fastened by the retaining rings. Instead it is fixed to the end of the probe rod by a hexagonal headed bolt (A4-70) and a Nord-Lock washer (1.4547).</p>

Accessory	Description
<p>Centering disk PFA Ø 37 mm (1.46") can be used for</p> <ul style="list-style-type: none"> ■ FMP51 ■ FMP52 ■ FMP54 	<div style="text-align: right;">mm (inch)</div>  <p>A: For 8 mm (0.3 in) probes B: For 12 mm (0.47 in) and 16 mm (0.63 in) probes</p> <p>The centering disk is suitable for probes with a rod diameter of 8 mm (0.31 in), 12 mm (0.47 in) and 16 mm (0.63 in) (also coated rod probes) and can be used in pipes from DN40 (1½") up to DN50 (2"). See also Operating Instructions BA378F.</p> <ul style="list-style-type: none"> ■ Material: PFA ■ Admissible process temperature: -200 to +200 °C (-328 to +392 °F) ■ Order code <ul style="list-style-type: none"> - Probe 8 mm (0.31 in): 71162453 - Probe 12 mm (0.47 in): 71157270 - Probe 16 mm (0.63 in): 71069065 <p> The PFA centering disk can also be ordered directly with the device (see the Levelflex product structure, feature 610 "Accessory mounted", option OE).</p>

Communication-specific accessories

Accessory	Description
Commubox FXA195 HART	<p>For intrinsically safe HART communication with FieldCare via the USB interface.</p> <p> For details refer to Technical Information TI404F/00</p>

Accessory	Description
Commubox FXA291	<p>Connects Endress+Hauser field devices with CDI interface (= Endress+Hauser Common Data Interface) to the USB interface of a computer.</p> <p> For details refer to Technical Information TI405C/07</p>

Accessory	Description
HART Loop Converter HMX50	<p>Evaluates the dynamic HART variables and converts them to analog current signals or limit values.</p> <p> For details refer to Technical Information TI429F/00 and Operating Instructions BA371F/00</p>

Accessory	Description
WirelessHART Adapter SWA70	<p>Connects field devices to a WirelessHART network.</p> <p>The WirelessHART adapter can be mounted directly at a HART device and is easily integrated into an existing HART network. It ensures safe data transmission and can be operated in parallel with other wireless networks.</p> <p> For details refer to Operating Instructions BA061S/04</p>

Accessory	Description
Fieldgate FXA320	Gateway for remote monitoring of connected 4-20mA measuring devices via web browser.  For details refer to Technical Information TI025S/04 and Operating Instructions BA053S/04



Accessory	Description
Fieldgate FXA520	Gateway for remote diagnosis and parametrization of connected HART measuring devices via web browser.  For details refer to Technical Information TI025S/04/xx and Operating Instructions BA051S/04

Accessory	Description
Field Xpert SFX100	Compact, flexible and robust industry handheld terminal for remote parametrization and measured value inspection via the HART output or via FOUNDATION Fieldbus .  For details refer to Operating Instructions BA060S/04

Service-specific accessories

Accessory	Description
FieldCare	Endress+Hauser's FDT-based Plant Asset Management tool. Helps to configure and maintain all field devices of your plant. By supplying status information it also supports the diagnosis of the devices.  For details refer to Operating Instructions BA027S/04 and BA059S/04

System components

Accessory	Description
Graphic Data Manager Memograph M	The graphic data manager Memograph M provides information on all the relevant process variables. Measured values are recorded correctly, limit values are monitored and measuring points analyzed. The data are stored in the 256 MB internal memory and also on an SD card or USB stick.  For details refer to Technical Information TI133R/09 and Operating Instructions BA247R/09
RN221N	Active barrier with power supply for safe separation of 4 to 20 mA current circuits. Provides bi-directional HART transmission.  For details refer to Technical Information TI073R/09 and Operating Instructions BA202R/09
RNS221	Transmitter supply for 2-wire sensors or transmitters exclusively for non-Ex areas. Provides bi-directional communication using the HART communication sockets.  For details refer to Technical Information TI081R/09 and Operating Instructions KA110R/09

Accessory	Description
Graphic Data Manager Memograph M	The graphic data manager Memograph M provides information on all the relevant process variables. Measured values are recorded correctly, limit values are monitored and measuring points analyzed. The data are stored in the 256 MB internal memory and also on an SD card or USB stick.  For details refer to Technical Information TI133R/09 and Operating Instructions BA247R/09

Documentation



The following document types are available:

- On the CD supplied with the device
- In the Download Area of the Endress+Hauser Internet site: www.endress.com → Download

Standard documentation

Levelflex FMP51, FMP52, FMP54

Correlation of documentations to the device:

Device	Power supply, output	Communication	Document type	Document code
FMP51, FMP52, FMP54	A, B, C, K, L	HART	Operating Instructions	BA01001F/00/DE
			Brief Operating Instructions	KA01077F/00/DE
			Description of Device Parameters	GP01000F/00/DE
	G	PROFIBUS PA	Operating Instructions	BA01006F/00/DE
			Brief Operating Instructions	KA01079F/00/DE
			Description of Device Parameters	GP01001F/00/DE
	E	FOUNDATION Fieldbus	Operating Instructions	BA01052F/00/EN
			Brief Operating Instructions	KA01107F/00/EN
			Description of Device Parameters	GP01015F/00/EN

Supplementary documentation

Device	Document type	Document code
Fieldgate FXA520	Technical Information	TI369F/00/EN
Tank Side Monitor NRF590	Technical Information	TI402F/00/EN
	Operating Instructions	BA256F/00/EN
	Description of Device Parameters	BA257F/00/EN

Description	Document type	Document code
Time of Flight Liquid Level Measurement Selection and engineering for the process industry	Special Documentation	SD157F/00/EN
Radar Tank Gauging brochure For inventory control and custody transfer applications in tank farms and terminals	Special Documentation	SD001V/00/EN

Certificates

Safety Instructions (XA) for Levelflex FMP51, FMP52, FMP54

Depending on the approval, the following Safety Instructions (XA) are supplied with the instrument. They are an integral part of the Operating Instructions.

51	52	54	Feature 010	Approval	Safety Instructions HART	Safety Instructions PROFIBUS FOUNDATION Fieldbus
x	x	x	BA	ATEX II 1 G Ex ia IIC T6 Ga	XA00496F	XA00516F
x	x	x	BB	ATEX II 1/2 G Ex ia IIC T6 Ga/Gb	XA00496F	XA00516F
x	x	x	BC	ATEX II 1/2 G Ex d[ia] IIC T6 Ga/Gb	XA00499F	XA00519F
x	x	x	BD	ATEX II 1/3 G Ex ic[a] IIC T6 Ga/Gc	XA00497F	XA00517F
		x	BE	ATEX II 1 D Ex t[ia] IIIC Txx°C Da IP6x	XA00501F	XA00521F
		x	BF	ATEX II 1/2 D Ex t[ia] IIIC Txx°C Da/Db IP6x	XA00501F	XA00521F
x	x	x	BG	ATEX II 3 G Ex nA IIC T6 Gc	XA00498F	XA00518F
x	x	x	BH	ATEX II 3 G Ex ic IIC T6 Gc	XA00498F	XA00518F

51	52	54	Feature 010	Approval	Safety Instructions HART	Safety Instructions PROFIBUS FOUNDATION Fieldbus
x	x	x	BL	ATEX II 1/3G Ex nA(ia) IIC T6	XA00497F	XA00517F
x	x	x	B2	ATEX II 1/2 G Ex ia IIC T6, 1/2D Ex ia IIIC IP6x	XA00502F	XA00522F
x	x	x	B3	ATEX II 1/2 G Ex d[ia] IIC T6 Ga/Gb, II 1/2 D Ex t[ia] IIIC Txx°C Da/Db IP6x	XA00503F	XA00523F
x	x	x	B4	ATEX II 1/2 G Ex ia IIC T6 Ga/Gb, Ex d[ia] IIC T6 Ga/Gb	XA00500F	XA00520F
		x	CD	CSA C/US DIP Cl.I,II Div.1 Gr.E-G	XA00529F	XA00570F
x	x	x	C2	CSA C/US IS Cl.I,II,III Div.1 Gr.A-G, NI Cl.1 Div.2, Ex ia	XA00530F	XA00571F
x	x	x	C3	CSA C/US XP Cl.I,II,III Div.1 Gr.A-G, NI Cl.1 Div.2, Ex d	XA00529F	XA00570F
x	x	x	FB	FM IS Cl.I,II,III Div.1 Gr.A-G, AEx ia, NI Cl.1 Div.2	XA00531F	XA00573F
x	x	x	FD	FM XP Cl.I,II,III Div.1 Gr.A-G, AEx d, NI Cl.1 Div.2	XA00532F	XA00572F
		x	FE	FM DIP Cl.II,III Div.1 Gr.E-G	XA00532F	XA00572F
x	x	x	IA	IECEEx Zone 0 Ex ia IIC T6 Ga	XA00496F	XA00516F
x	x	x	IB	IECEEx Zone 0/1 Ex ia IIC T6 Ga/Gb	XA00496F	XA00516F
x	x	x	IC	IECEEx Zone 0/1 Ex d[ia] IIC T6 Ga/Gb	XA00499F	XA00519F
x	x	x	ID	IECEEx Zone 0/2 Ex ic[ia] IIC T6 Ga/Gc	XA00497F	XA00517F
		x	IE	IECEEx Zone 20 Ex t[ia] IIIC Txx°C Da IP6x	XA00501F	XA00521F
		x	IF	IECEEx Zone 20/21 Ex t[ia] IIIC Txx°C Da/Db IP6x	XA00501F	XA00521F
x	x	x	IG	IECEEx Zone 2 Ex nA IIC T6 Gc	XA00498F	XA00518F
x	x	x	IH	IECEEx Zone 2 Ex ic IIC T6 Gc	XA00498F	XA00518F
x	x	x	IL	IECEEx zone 0/2 Ex nA(ia) IIC T6 Ga/Gc	XA00497F	XA00517F
x	x	x	I2	IECEEx zone 0/1 Ex ia IIC T6 Ga/Gb, zone 20/21 Ex ia IIIC A20/21 IP6x, Da/Db	XA00502F	XA00522F
x	x	x	I3	IECEEx Zone 0/1 Ex d[ia] IIC T6 Ga/Gb, Zone 20/21 Ex t[ia] IIIC Txx°C Da/Db IP6x	XA00503F	XA00523F
x	x	x	NA	NEPSI Zone 0 Ex ia IIC T6 Ga	XA00634F	XA00640F
x	x	x	NB	NEPSI Zone 0/1 Ex ia IIC T6 Ga/Gb	XA00634F	XA00640F
x	x	x	NC	NEPSI Zone 0/1 Ex d(ia) IIC T6 Ga/Gb	XA00636F	XA00642F
		x	NF	NEPSI Zone 20/21 tD IIIC A20/21 IP6x Da/Db	XA00637F	XA00643F
x	x	x	NG	NEPSI Zone 2 Ex nA II T6 Gc	XA00635F	XA00641F
x	x	x	NH	NEPSI Zone 2 Ex ic IIC T6 Gc	XA00635F	XA00641F
x	x	x	N2	NEPSI zone 0/1 Ex ia IIC T6 Ga/Gb, zone 20/21 Ex iaD 20/21 T*	XA00638F	XA00644F
x	x	x	N3	NEPSI zone 0/1 Ex d(ia) IIC T6 Ga/Gb, DIP A20/21 T* IP66	XA00639F	XA00645F
x	x	x	8A	FM/CSA IS+XP Cl.I,II,III Div.1 Gr.A-G	XA00531F XA00532F	XA00572F XA00573F



For certified devices the relevant Safety Instructions (XA) are indicated on the nameplate.

Registered trademarks

HART®

Registered trademark of the HART Communication Foundation, Austin, USA

PROFIBUS®

Registered trademark of the PROFIBUS User Organization, Karlsruhe, Germany

FOUNDATION™ Fieldbus

Registered trademark of the Fieldbus Foundation, Austin, Texas, USA

KALREZ®, VITON®

Registered trademark of DuPont Performance Elastomers L.L.C., Wilmington, USA

TEFLON®

Registered trademark of E.I. DuPont de Nemours & Co., Wilmington, USA

TRI CLAMP®

Registered trademark of Alfa Laval Inc., Kenosha, USA

Patents

This product may be protected by at least one of the following patents.

Further patents are pending.

US Patents	EP Patents
5.827.985	—
5.884.231	—
5.973.637	—
6.087.978	955 527
6.140.940	—
6.481.276	—
6.512.358	1 301 914
6.559.657	1 020 735
6.640.628	—
6.691.570	—
6.847.214	—
7.441.454	—
7.477.059	—
—	1 389 337
7.965.087	—

Instruments International

Endress+Hauser
Instruments International AG
Kaegenstrasse 2
4153 Reinach
Switzerland

Tel.+41 61 715 81 00
Fax+41 61 715 25 00
www.endress.com
info@ii.endress.com

Endress + Hauser 
People for Process Automation

